

PIONEER

SG-9500

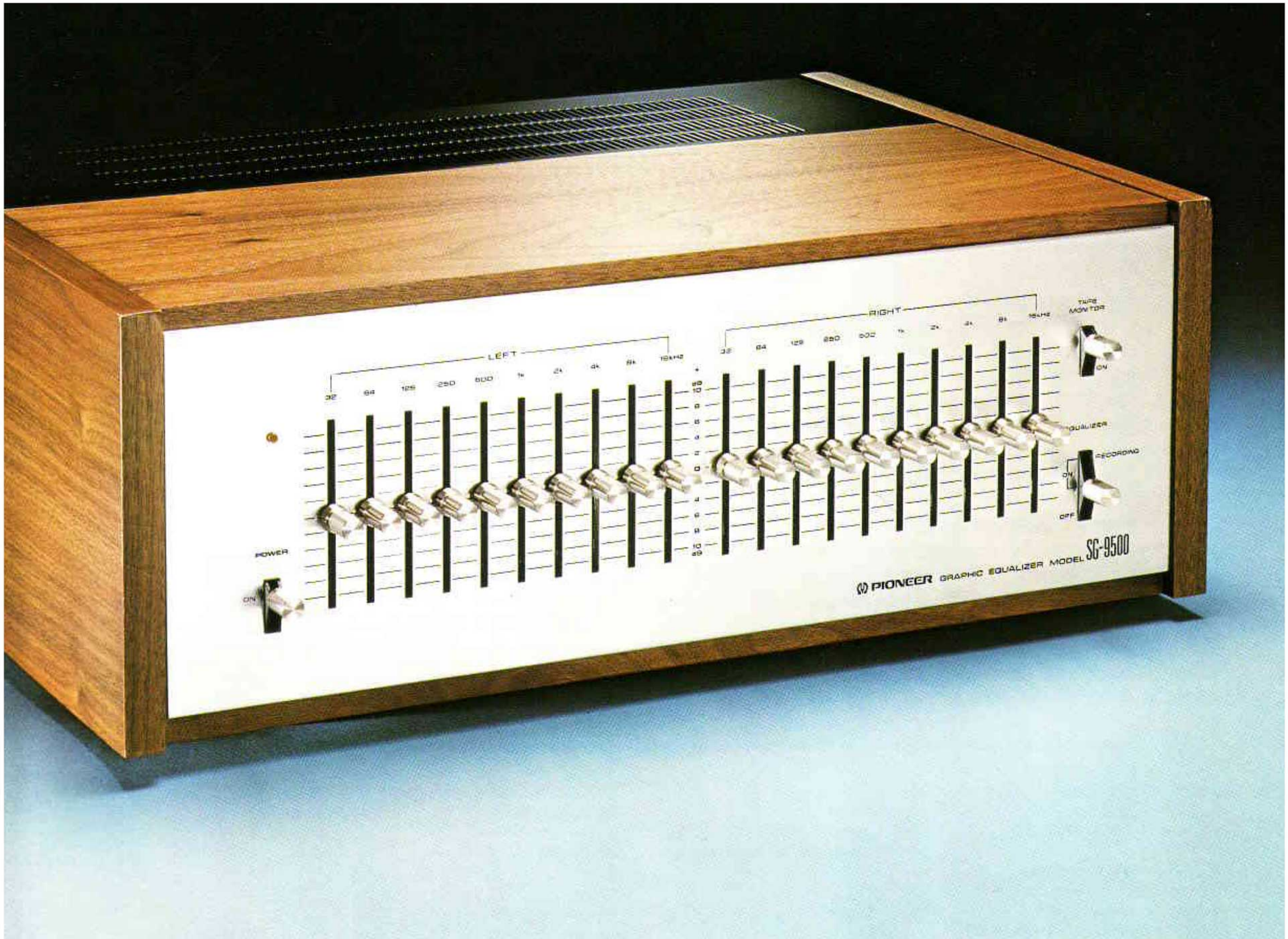

Unique Stereo Graphic Equalizer for Impeccable Tonal Control of Any Frequency Response and Sound Field.

Pioneer has created the SG-9500 Stereo Graphic Equalizer so that you, the music listener, can create the most ideal sound field by more delicately and accurately controlling frequency response. Distinctively designed and finished, the SG-9500 works to complement the sound personalities of your stereo cartridge, microphone, tape equipment and speakers. In the broadest sense, the

SG-9500 actually "hand-tailors" your music and its myriad tonal qualities to enhance your music-listening pleasure. The stereo perfectionist, and we hope this is you, could hardly ask for a more precise, more complete instrument to add the perfect finishing touches to his musical sound field.

NOTE: (1) A walnut case is optional.

(2) Walnut veneered top and side panels are used in the construction of this cabinet.

SG-9500

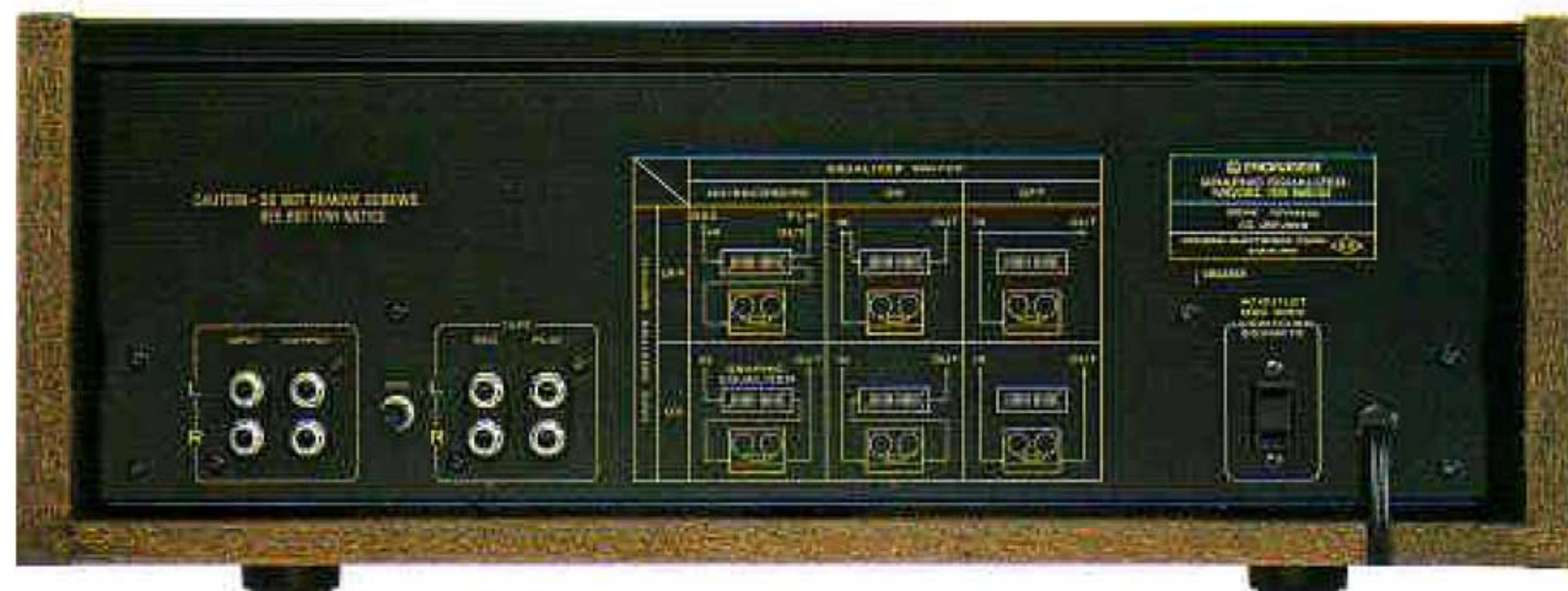
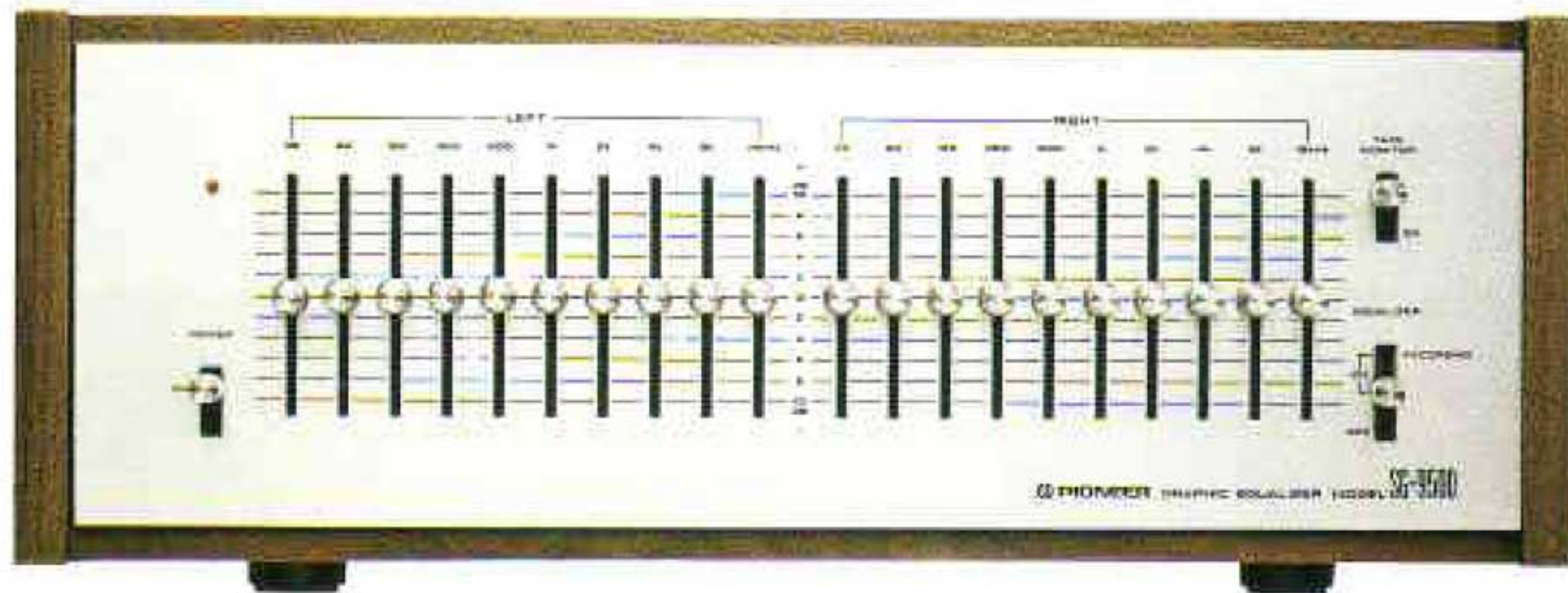

LEVEL CONTROL WITH ONE OCTAVE CUTOFF, INDEPENDENT LEFT AND RIGHT CHANNELS

The level control is cut off by one octave in 10 elements of 32Hz, 64Hz, 125Hz, 250Hz, 500Hz, 1kHz, 2kHz, 4kHz, 8kHz, and 16kHz, and the left channel (L. ch) and right channel (R. ch) can be operated independently. The variable range of each element is ± 10 dB.

IC OPERATION AMPLIFIER

Unlike any other graphic equalizer, SG-9500 uses an Integrated Circuit instead of ordinary coils and capacitors. The IC contains 20 transistors and 2 diodes (x10 elements) and each IC operates as an active bandpass filter by negative feedback technology. This helps minimize distortion and contributes to expansion of dynamic range.

MULTIPLE REPRODUCTION AND RECORDING TECHNIQUES

By combining the TAPE MONITOR SWITCH and EQUALIZER SWITCH, six different recording and reproducing methods can be accomplished without connecting or disconnecting the cords of the SG-9500. With the EQUALIZER SW switched off, the EQUALIZER circuit is bypassed. Reference to the wiring diagram reproduced on the unit's rear panel as shown below, adds to the convenient reproduction and recording possibilities of the SG-9500.

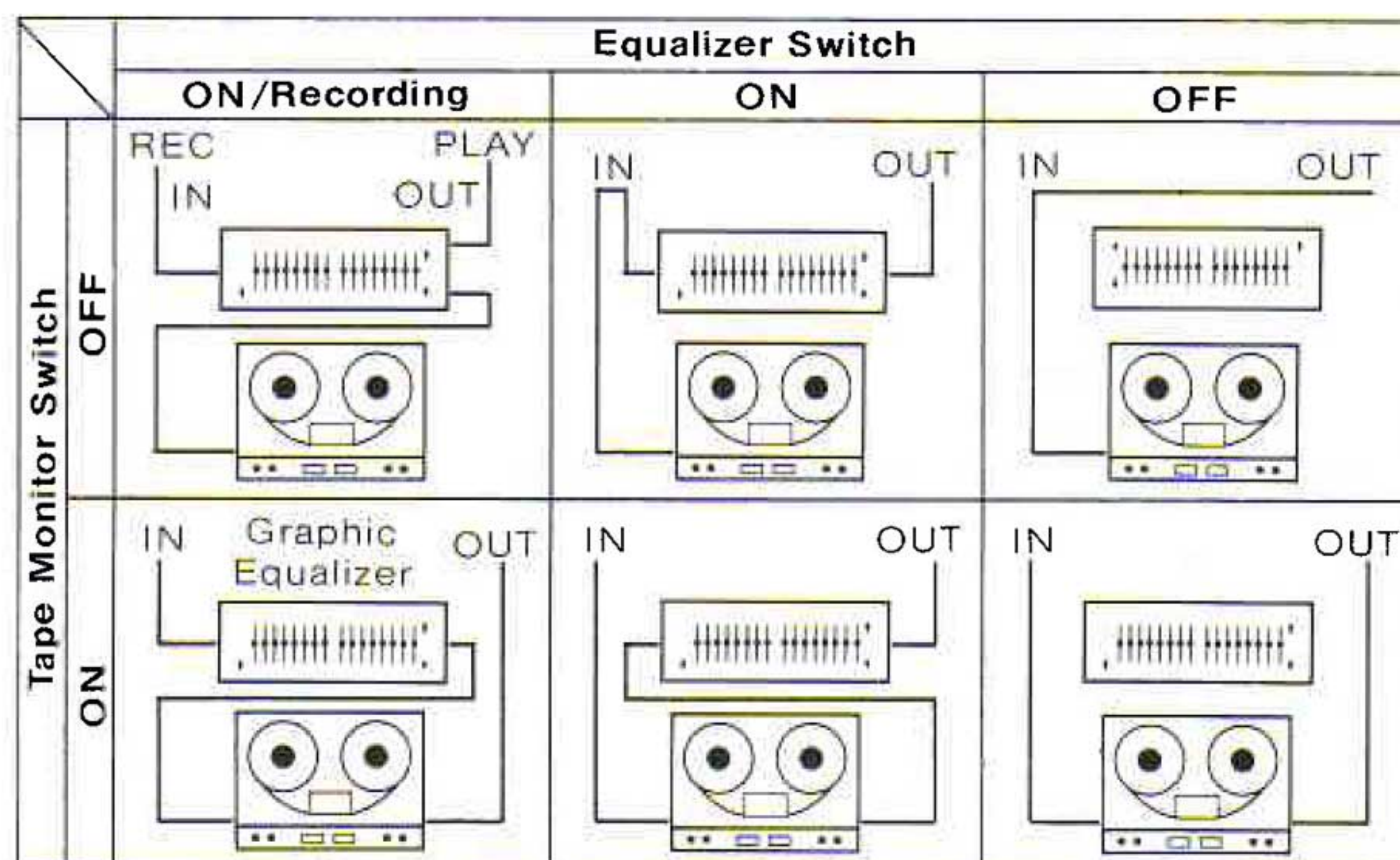

PURE FET-EQUIPPED ELECTRONIC TYPE MUTING

A pure electronic type control muting circuit is employed in the SG-9500 with an FET in the output stage in series. This eliminates pop noises when power is switched on and off.

PROFESSIONAL, DISTINCTIVE DESIGN

The SG-9500 is a beautifully designed instrument that will make a handsome addition to any existing stereo system. Its immaculate aluminum surface and professional knob-layout contributes to efficient operation.

SG-9500 SPECIFICATIONS

EQUALIZER SECTION

Equalizer Range	± 10 dB,
(Individual Channel Adjust):	32Hz, 64Hz, 125Hz, 250Hz, 500Hz, 1kHz, 2kHz, 4kHz, 8kHz, 16kHz
Total Harmonic Distortion:	
20Hz to 20kHz, All Control Flat	
Output 1V:	0.04%
1kHz, All Control Max. Output 3V:	0.04%
1kHz, All Control Flat Output 2V:	0.03%
1kHz, All Control Min. Output 1V:	0.05%
Insertion Loss:	0dB (Control Flat)
Max. Output Voltage	
(1kHz, T.H.D.: 0.05%, R_L 47 Kohms):	6V
Frequency Response:	5Hz to 70kHz ± 0 dB, -1 dB
Signal-to-Noise Ratio	

(IHF, Short circuited A Network, 2V Output): 90dB

Input Impedance: 100 Kohms

Output Impedance: 600 ohms

SEMICONDUCTORS

ICs: 14

FETs: 2

Transistors: 12

Diodes: 13

MISCELLANEOUS

Power Requirement: 120V/60Hz only

Power Consumption: 16 watts

Dimensions:

Without package:

16-1/2(W) x 5-7/8(H) x 13-7/16(D) inches

420(W) x 150(H) x 341(D) mm

Weight:

Without package: 15 lb. 3 oz/6.9kg



PIONEER ELECTRONIC CORPORATION / 4-1, Meguro 1-chome, Meguro-ku, Tokyo 153, Japan

U.S. PIONEER ELECTRONICS CORP. / 85 Oxford Drive, Moonachie, New Jersey 07074, U.S.A.

PIONEER ELECTRONIC (EUROPE) N.V. / Luithagen-Haven 9, 2030 Antwerp, Belgium

PIONEER ELECTRONICS AUSTRALIA PTY.LTD. / 178-184 Boundary Road, Braeside, Victoria 3195, Australia