

OPERATING INSTRUCTIONS & SERVICE MANUAL

AM/FM STEREO AMPLIFIER

SANSUI AU-7500

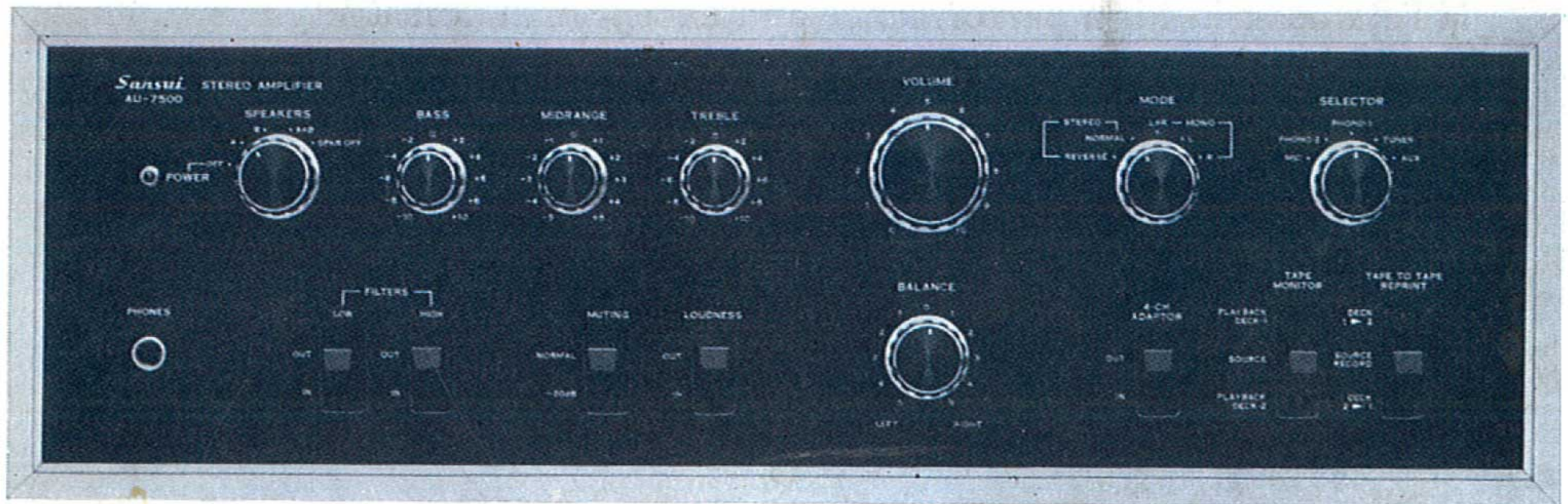

Sansui

SANSUI ELECTRIC CO., LTD.

We are grateful for your choice of the AU-7500 Integrated Amplifier.

For over a quarter of a century, Sansui has been building hi-fi audio equipment, and nothing else. Our mission is very old and at once ever new to us: to bring the reproduced sound closer and closer to the original.

The AU-7500 now in your hands is one answer from us to this never-ending quest. It is a product of the cream of sophisticated modern audio-electronics knowhow, coupled with our long experience, and as such, we present it to you with our full confidence. The AU-7500 is a new breed of Sansui's AU series integrated amplifiers. Its tone quality has been polished and perfected through an unprecedented number of listening tests in different acoustic environments. We feel certain that you will like it, but you will find this out as soon as you play your first record through it.

This manual has been prepared to guide you in operating and caring for the amplifier correctly, so that you will get the most out of its built-in high performance and exceptional versatility.

May we suggest that you read it once carefully?

CONTENTS

SWITCHES AND CONTROLS	3, 4
SETTING UP YOUR AU-7500/ OPERATING PROCEDURE	5, 6
RECORDING AND PLAYBACK BY TAPE DECKS.....	7
UPGRADING YOUR STEREO (4-CHANNEL STEREO SYSTEM/ELECTRONIC CROSSOVER SYSTEM)	8
SIMPLE MAINTENANCE HINTS/ACCESSORY LIST ...	9, 10
QUICK CHECK LIST OF SIMPLE MISTAKES.....	11
SPECIFICATIONS	12
SCHEMATIC DIAGRAM	13, 14
NOTES TO SERVICE ENGINEERS	15
GENERAL TROUBLESHOOTING CHART	16
DISASSEMBLY PROCEDURE	17
ALIGNMENT	18
PRINTED CIRCUIT BOARDS AND PARTS LIST.....	19~24
OTHER PARTS AND THEIR POSITION ON CHASSIS...	25, 26

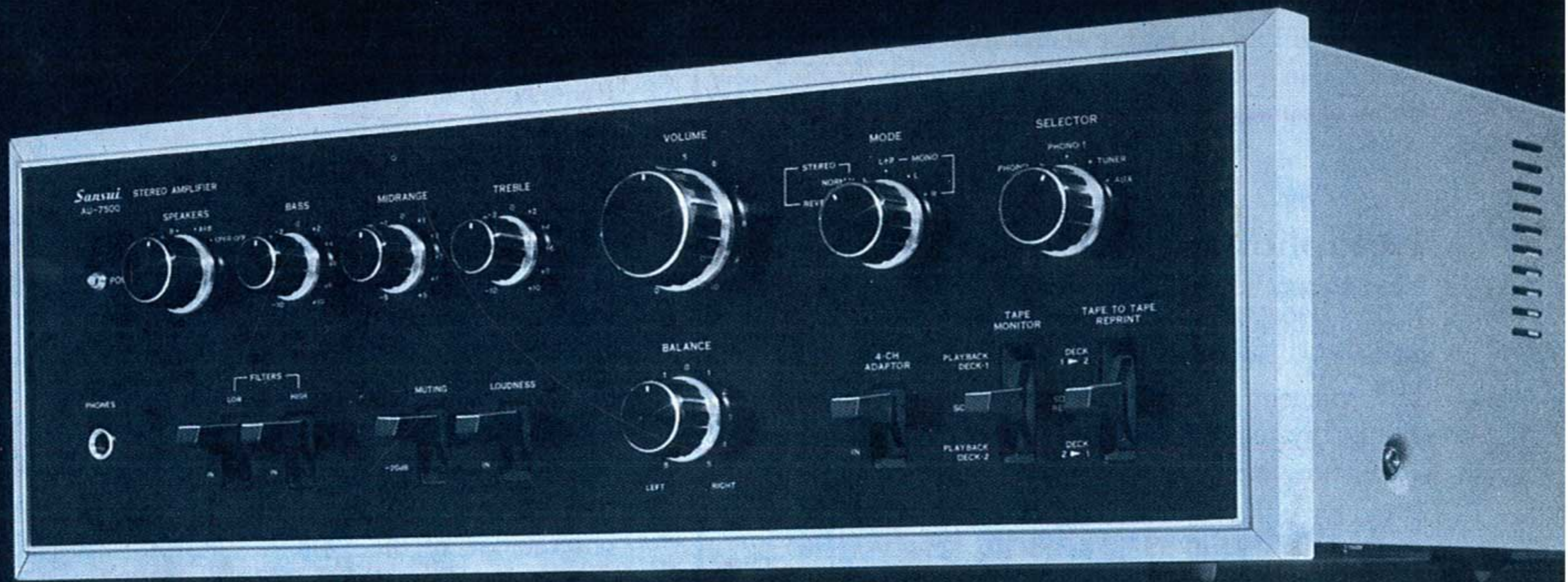

SWITCHES AND CONTROLS

Power Indicator

Lights when you turn on the Power/Speakers Switch, and remains lit until you turn off the switch.

Power/Speakers Switch

Controls both the power supply and selection of speaker systems.

POWER OFF: Cuts off power supply for the amplifier.

A: Turns on power supply and energizes the speaker systems connected to SYSTEM-A speaker terminals on the rear. Because of the builtin amplifier/speaker protection circuit, sound will come out with a delay of a few seconds.

B: Energizes speaker systems connected to SYSTEM-B speaker terminals.

A+B: Energizes both A and B pairs of speaker systems.

SPKR OFF: Cuts off the sound from all speaker systems to permit private listening with headphones connected to the Headphone Jack.

Headphone Jack

Plug stereo headphones into this jack for private listening or monitoring, but be sure to turn the Power/Speakers Switch to SPKR OFF first unless someone is listening to the sound from speaker systems in another room. The jack will accept any standard stereo phone plug, but for best tone quality, we recommend a dynamic type such as the Sansui SS-20 or SS-10.

Filters

Low: Push down to IN to eliminate low-frequency noise such as the rumbling of your turntable motor. If no such noise is present, be sure to keep it off.

High: Push down to IN to eliminate high-frequency noise such as the surface noise from a worn record or as the fluorescent lamp noise mixed in radio broadcasts.

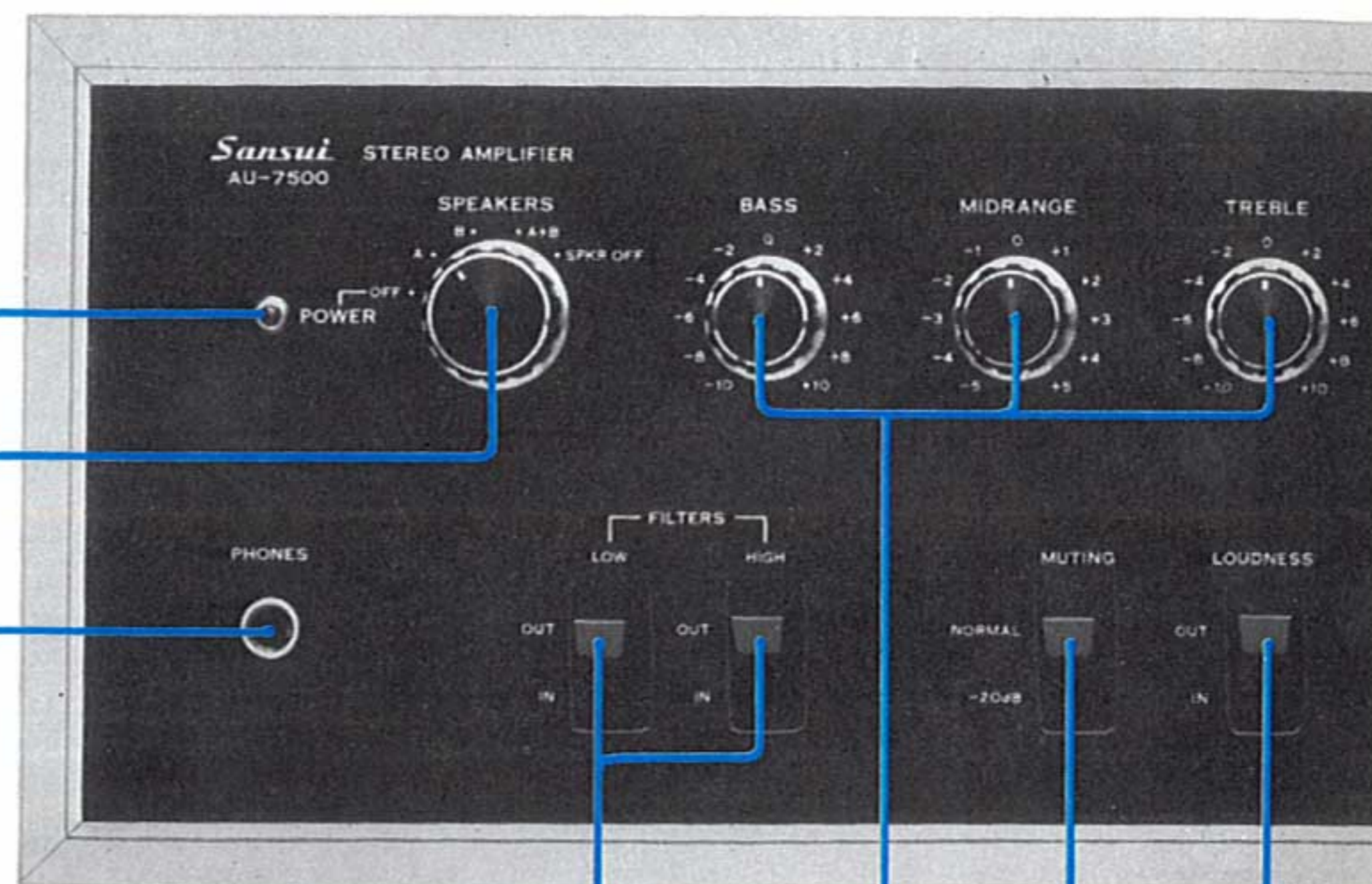

Triple Tone Controls

Let you tailor the tone quality of reproduced sound to your taste by adjusting the amplifier's frequency response curve. The Bass Control is for adjusting the loudness of bass notes as may be produced by a bass; the Midrange one for adjusting that of middle range notes as may be produced by the human voice, and the Treble one for adjusting that of treble notes as may be produced by cymbals.

Muting Switch

Reduces the sound volume by 20dB at once without the use of the Volume Control. Most convenient to lower the sound volume temporarily when the telephone rings, to avoid the noise of the pickup stylus descending on a record, etc.

Loudness Switch

If desired, push down to IN to emphasize the highs and lows when listening at low volume levels. This is because the mechanism of human hearing is such that the high and low notes seem greatly enfeebled at low listening levels.

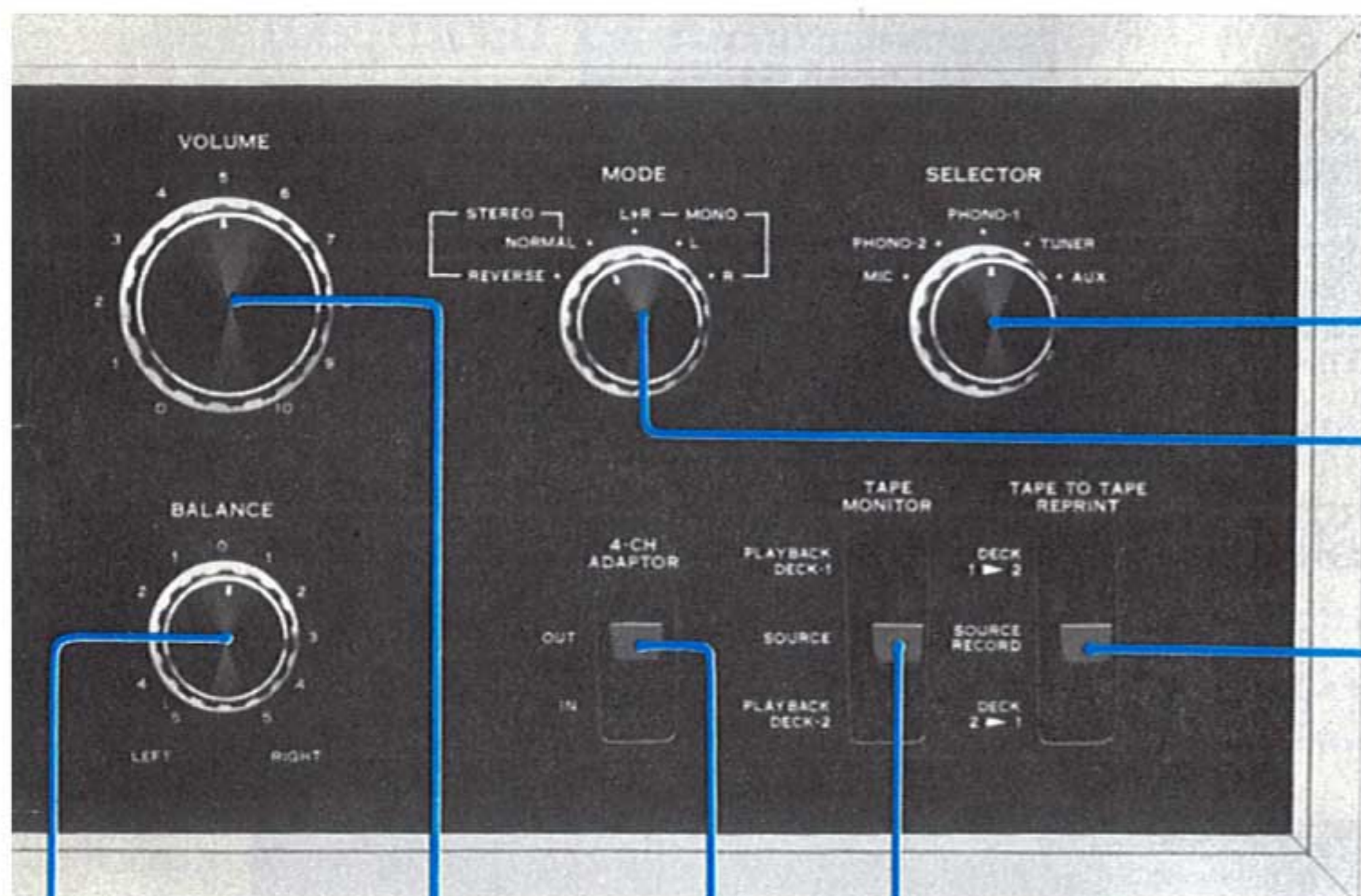

Volume Control

Tape Monitor Switch

The AU-7500 connects two tape decks at a time. Set this switch to **PLAYBACK DECK-1** or **PLAYBACK DECK-2** to reproduce a recorded tape or monitor a recording as you make it on a tape deck connected to the amplifier (monitoring is possible only if the tape deck is equipped with separate recording and playback heads). Otherwise, be sure to keep it at **SOURCE**.

4-Channel Adaptor Switch

If you connect a 4-channel adaptor to the AU-7500 and make other necessary connections, you can upgrade this 2-channel stereo amplifier to hear 4-channel stereo sound by pushing this switch down to **IN** (refer to page 8).

Balance Control

Set the Mode Switch to **MONO L+R** once and adjust this control for equal sound volume from the left and right speaker systems, then return the switch to **STEREO NORMAL**. If there is a large difference in the sound volumes from the two speaker systems even with this control set near the center, it may be because left and right output signal levels from the program source component (turntable, tuner, tape deck, etc.) are different. Check the component once.

Selector Control

Turn to an appropriate position to hear the desired program source.

MIC: To use microphones (high impedance type of 10 kilo-ohms or more) plugged into the Mic Jacks on the rear.

PHONO-2, PHONO-1: To play records on a turntable connected to the PHONO 2 or 1 terminals on the rear. The input impedance of the PHONO-2 circuit is adjustable with the rear-panel Pickup Load Switch to match the load impedance of the cartridge in use.

TUNER: To hear a radio broadcast from a tuner connected to the TUNER terminals on the rear.

AUX: To reproduce whatever program source is connected to the AUX terminals on the rear. (Connect a turntable with a crystal or ceramic cartridge, the audio outputs of a television, the playback outputs of a tape recorder, etc. to the AUX terminals.)

Mode Switch

STEREO: The **NORMAL** position is normal. If you have connected the left and right speaker systems in reverse, set this switch to **REVERSE** to restore the normal stereo effect without physically changing the speaker connections.

MONO: Set to **L+R**, and the monophonic mixture of the left and right channel signals is heard from both speaker systems. Set to **L(R)**, and only the left (right) channel signal is heard from both speaker systems.

Tape-to-Tape Reprint Switch

If you have two tape decks connected to the amplifier, you can copy a recorded tape from one to the other.

DECK 1 ► 2: To record from the tape deck connected to the TAPE DECK-1 terminals on the rear to the one connected to the TAPE DECK-2 terminals.

DECK 2 ► 1: Reverse of the above.

SOURCE RECORD: To record or play on one tape deck alone. When neither of the above procedures is desired, keep the switch in this position.

SETTING UP YOUR AU-7500 / OPERATING PROCEDURE

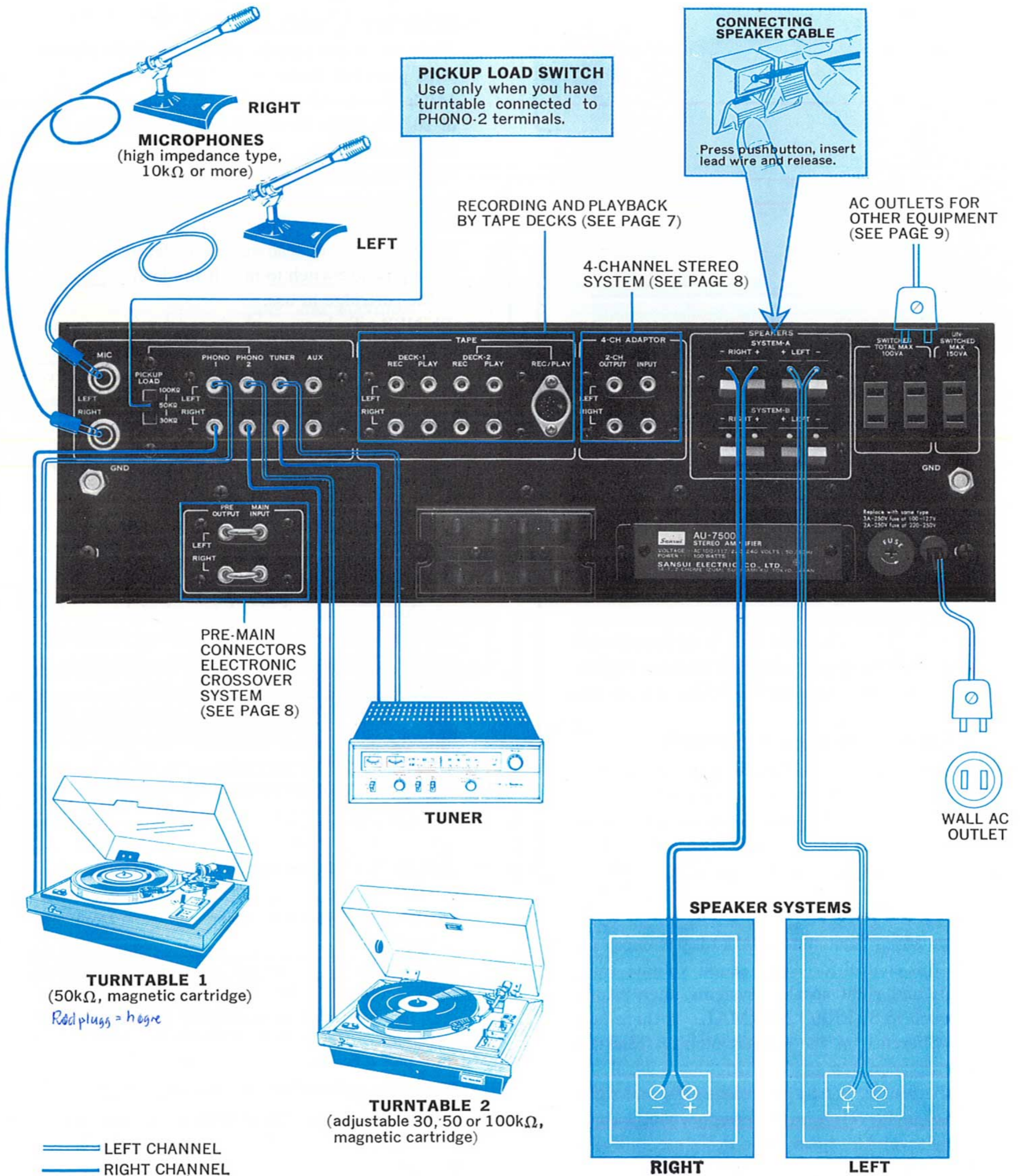

Required Connections

Speaker Systems: If you are connecting only **one pair of speaker systems** to the AU-7500, they may have any impedance from 4 to 16 ohms. Connect them to the SYSTEM-A or -B terminals on the rear, making sure not to confuse the left and right cables, plus and minus leads on the amplifier and speaker ends.

But if you wish to connect **two pairs of speaker systems** and drive them simultaneously by turning the Power/Speakers Switch to A+B, each speaker system should have impedance of 8 to 16 ohms. Using a system with lower impedance could result in a breakdown of the amplifier.

Turntable: Connect it to the PHONO 1 or 2 terminals on the rear. For best results, use a turntable with a magnetic pickup cartridge.

The PHONO-1 input circuit has impedance of 50 kilo-ohms, enabling it to accept most cartridges. The impedance of the PHONO-2 circuit, however, is adjustable between 30 and 100 kilo-ohms with the Pickup Load Switch. If your cartridge requires load resistance considerably smaller or greater than 50 kilo-ohms, connect it to the PHONO 2 terminals and set the switch to the nearest ohm value.

Microphone: Connect high-impedance (10 kilo-ohms or more) microphones to the Mic Jacks on the rear. If you want to use low-impedance (e.g., 600 ohms) microphones, you need an impedance matching transformer between the amplifier and microphones.

Tuner: Connect the output terminals of a tuner to the TUNER input terminals on the amplifier's rear panel.

Grounding: Be sure to connect the grounding terminal (or lead) of the turntable and tuner to the grounding terminal of the amplifier. It may suppress the hum noise which may otherwise occur.



Operating Procedure

1. Set the Selector Control to the desired program source.
2. Turn the Mode Switch to STEREO NORMAL. If you are using a monophonic turntable or a single microphone, set the switch to either L or R, whichever input circuit is connecting the device.
3. Set the 4-channel Adaptor Switch to OUT and the Tape Monitor Switch to SOURCE, unless you want to use them.
4. Set the Power/Speakers Switch to as required.
5. Start the program source component and play the program source.
6. Use the amplifier's other controls and switches to suit your taste or room acoustics.

Note:

1. To play a monophonic record on a stereo turntable, follow the same procedure as for playing a stereo record. Better results are normally obtained.
2. If you raise the sound volume when you are using a microphone or microphones in an acoustically reflective room, loud oscillating noise may be emitted from the speaker systems. This is a phenomenon called howling and is no fault of the amplifier. It can be corrected either by lowering the volume or directing or moving the microphone(s) away from the speaker systems.

RECORDING AND PLAYBACK BY TAPE DECKS

Connecting Tape Decks

The AU-7500 connects up to two tape decks for recording and playback. Connect the input terminals of a tape deck to either TAPE DECK-1 or 2 REC terminals of the amplifier, and its output terminals to the PLAY terminals of the same circuit.

The DIN socket is a part of the TAPE DECK-2 circuit and can be used only if your tape deck is equipped with a similar socket. It is manufactured according to the German industrial standard to permit tape recording and playback from a single cable with a special 5-pin plug on each end.

Should you wish to connect more than two tape decks, you may connect it to the 4-CH ADAPTOR terminals. The OUTPUT terminals have the same electrical function as the REC terminals, while the INPUT terminals are equivalent to the PLAY terminals.

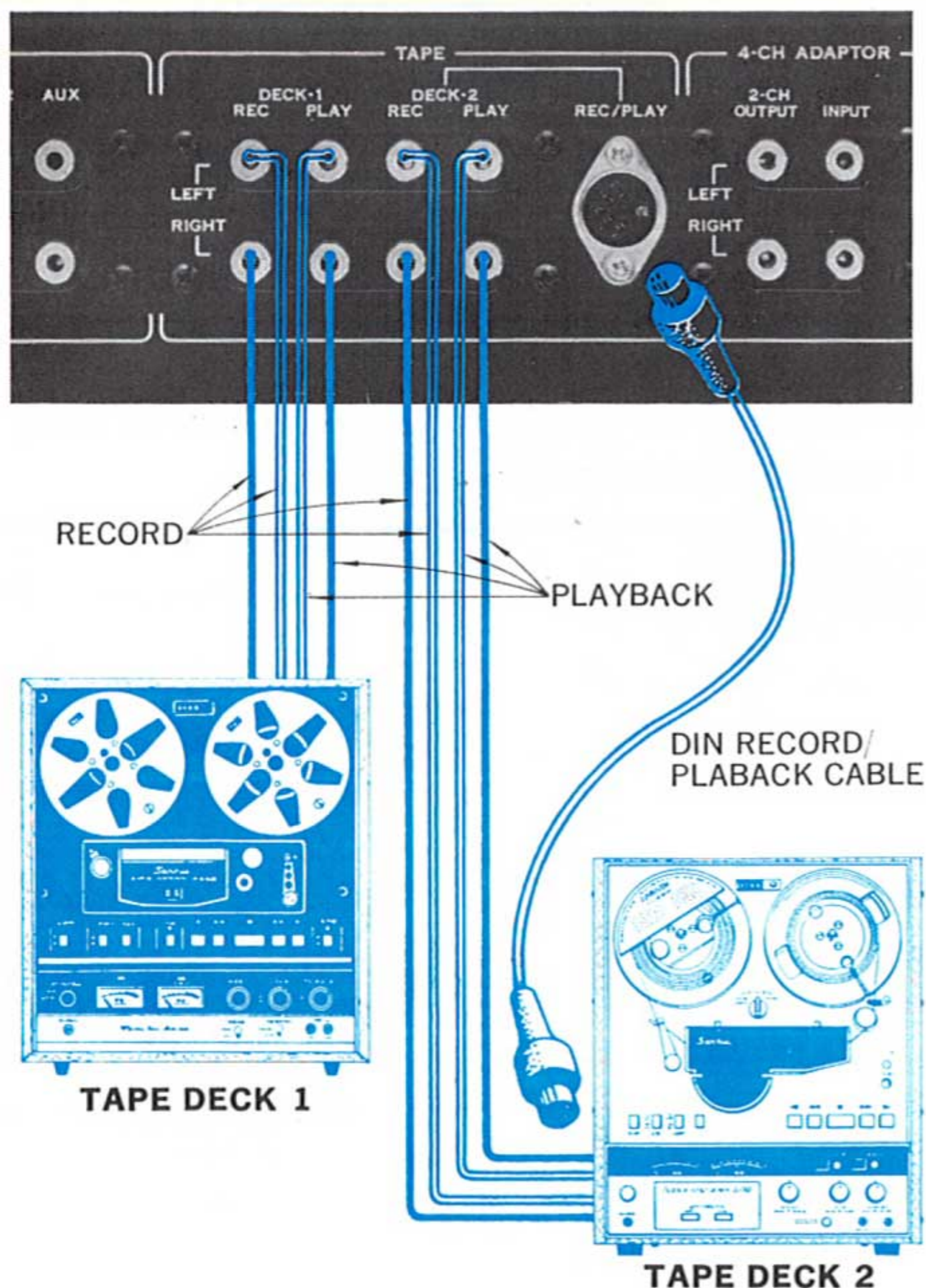

NOTE: Do not connect tape deck(s) to pin jack terminals and DIN socket of TAPE DECK-2 circuit simultaneously.

— LEFT CHANNEL
— RIGHT CHANNEL

Recording & Playback Procedure

Recording

1. Set the Selector Control to the program source you wish to record.
2. Adjust the recording volume control of the tape deck to preset the recording level.
3. Start the tape deck in the recording mode.
4. To monitor, follow the same procedure as indicated in the section entitled 'Playback'.

Playback

1. Set the Tape Monitor Switch to PLAYBACK DECK-1 or 2.
2. Start the tape deck in the playback mode.
3. Use the amplifier's other switches and controls to suit your taste and room acoustics.

Procedure for Copying a Recorded Tape

Depending on which tape deck you wish to use for recording, set the Tape-to-Tape Reprint Switch correctly. That is, if you are copying from the tape deck connected to the TAPE DECK-1 terminals to the one connected to the TAPE DECK-2 terminals, set it to DECK 1▶2. If you want to do it the other way around, set it to DECK 2▶1.

By operating the Tape Monitor Switch, you can monitor the recording as you copy it from one tape deck to the other. Set the switch to the tape deck you are using to reproduce, and you can monitor the recording before it is copied. Set it to the tape deck you are using to record, and you can monitor the recording after it is copied.

Notes about Recording

1. Monitoring of recorded sound is possible only if the recording tape deck is equipped with separate heads for recording and playback. Otherwise, set the Tape Monitor Switch to SOURCE and listen to the original input sound before it is recorded.
2. The various switches and controls on the AU-7500 do not affect the sound recorded into the tape deck. They only adjust the sound from the speaker systems or headphones.
3. When copying a recorded tape from one tape deck to the other, setting the Tape Monitor Switch to SOURCE electrically separates the tape record/playback circuits from the rest of the amplifier. You can use the amplifier to play records or hear radio broadcasts while the copying is underway.

UPGRADING YOUR STEREO

4-Channel Stereo System

The sound we hear daily is a mixture of the sound that reaches our ears straight from the sound source—be it a musical instrument, a jet, a man's mouth or what have you—and the 'indirect sounds' that arrive at your ears only after they are reflected off various surfaces, such as the walls, ceiling and so forth.

Four-channel recordings are made using two microphones in the front of the concert hall and two in the rear (to simplify the explanation). The 'indirect sounds' with their complicated waveforms are mainly picked up by the two microphones in the rear, and reproduced out of the two rear speakers in a 4-channel stereo set-up for greatly enhanced 'ambience' effects. The effect is almost as if the original live performance were re-played right in your own room. This new approach can now be yours simply by adding certain equipment—mainly, a Sansui 4-channel rear amplifier with its unique QS (RM) synthesizer decoder matrix (patents pending), and a second pair of speaker systems—to your 2-channel stereo system.

Connection of such a rear amplifier or 4-channel adaptor is easy. Just connect the 4-CH ADAPTOR 2-CH OUTPUT terminals of the AU-7500 with the input terminals of such rear amplifier or 4-channel adaptor, then connect its 4-CH ADAPTOR INPUT terminals with the output terminals of such unit.

To operate the rear amplifier or 4-channel adaptor so connected, push the 4-Channel Adaptor Switch on the amplifier's front panel, and otherwise follow its manufacturer's instructions. Electrically, the 4-CH ADAPTOR 2-CH OUTPUT and INPUT terminals possess the same functions as the TAPE REC and MON terminals, respectively.

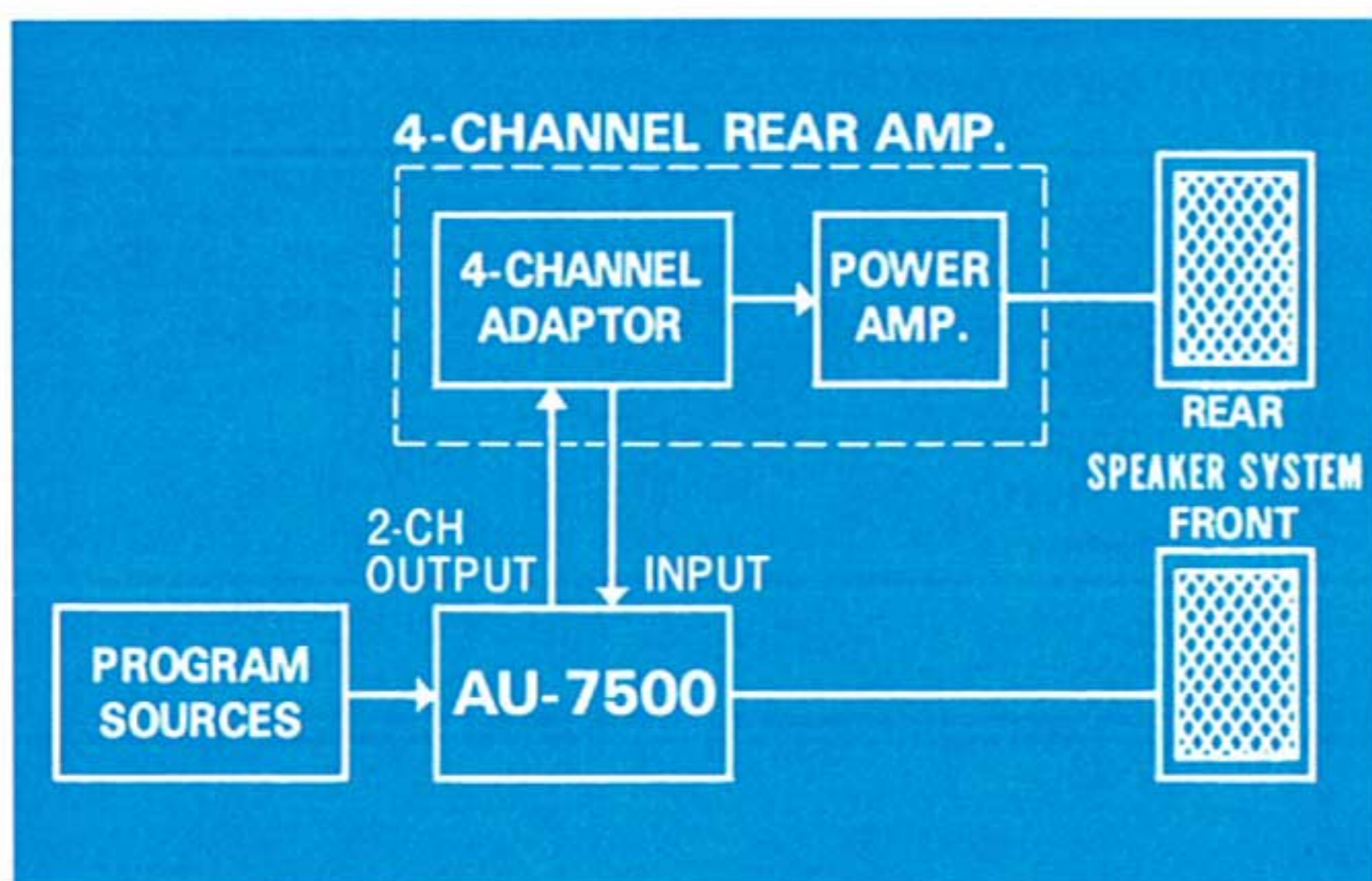

Electronic Crossover System

The electronic crossover system affords these advantages:

1. It enables the tweeters, midranges and woofers to be driven by separate power amplifiers. So you can make optimum use of speakers of different impedances and efficiencies, as well as power amplifiers of different output capacities and tone qualities.
2. It eliminates the need for the conventional LC type crossover network. With the electronic crossover divider, the amplifier's damping factor is no longer affected and you can set crossover frequencies as you like.

Electronic Crossover System Using the AU-7500

The preamplifier and power amplifier sections of the AU-7500 can be disconnected for independent usage, the latter section being available for driving a separate speaker in an electronic crossover system. To build such a system, you will need two- or three-way speaker systems and an electronic crossover divider, along with and at least one or two additional power amplifiers.

Connection is not all that difficult. First remove the Pre-Main Connectors uniting the amplifier's pre-amplifier outputs and main (power) amplifier inputs. Then just connect the PRE OUTPUT to the input terminals of the electronic crossover divider, which divides the input signals into high, medium and low range(s). Finally, couple the separate output terminals of the electronic crossover divider to the amplifier's MAIN INPUT and the additional power amplifier(s), feeding their outputs separately into individual speakers, as illustrated below.

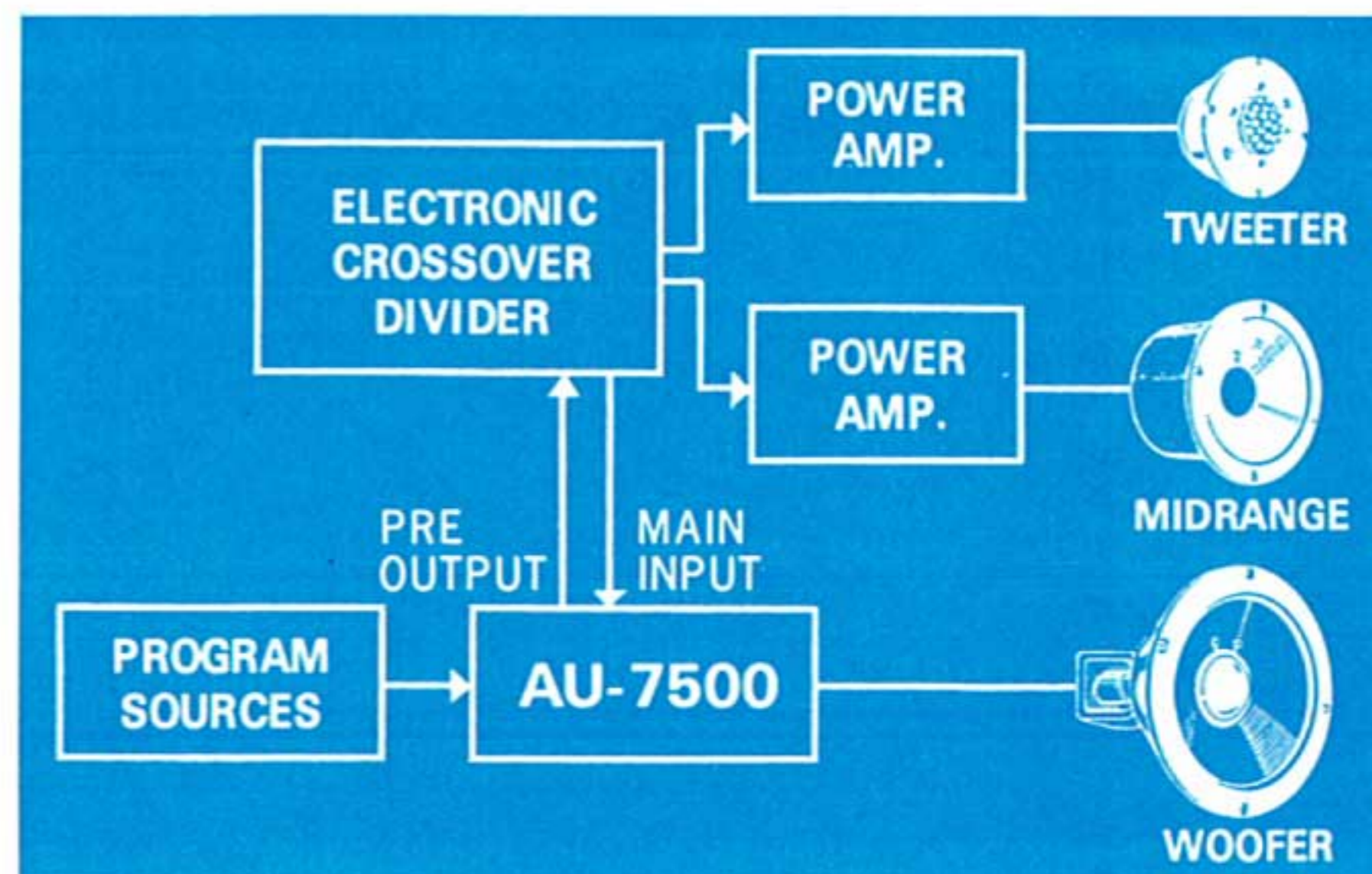

SIMPLE MAINTENANCE HINTS/ACCESSORY LIST

Real-Panel AC Outlets

Of the three AC outlets provided on the rear panel, the ones marked 'SWITCHED' are controlled by the front-panel Power/Speakers Switch. The third one, marked 'UNSWITCHED,' is always 'live' and independent of the Power/Speakers Switch. The voltage delivered at these AC outlets is the same as the power supply voltage used.

The two 'SWITCHED' outlets have a total power capacity of 100VA, and the UNSWITCHED one 150VA. Before you connect any appliance to them, be sure that it is adjusted for use at the same power supply voltage, and that its power consumption is not beyond these figures. Otherwise, serious danger could result.

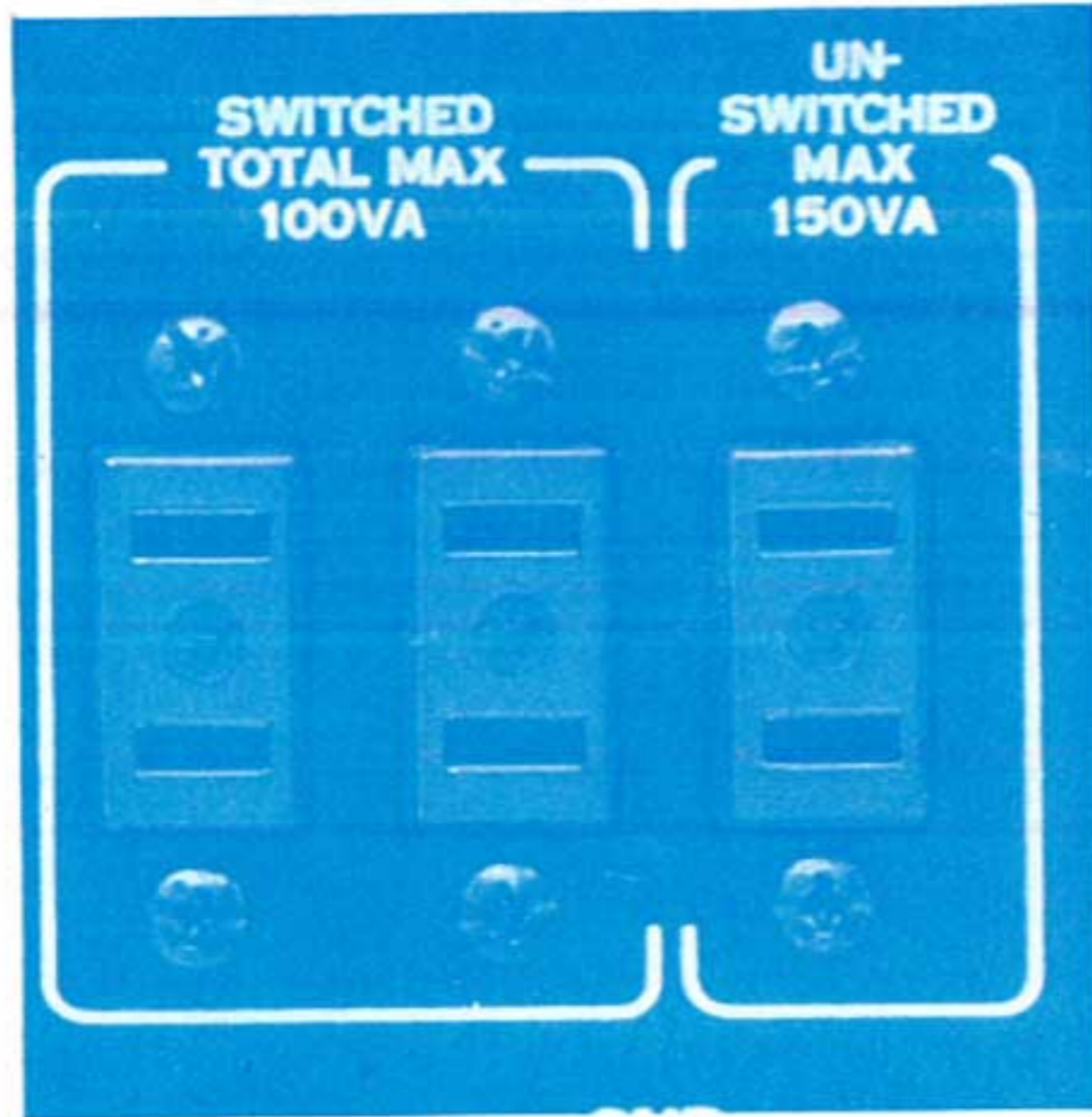

Make Proper Connections

Connect the leadwires of speaker cables properly. If they are loose or touch other parts, the amplifier may produce noise and eventually break down. Also, before connecting a turntable, tuner and/or tape deck, be sure to read their manufacturers' instructions.

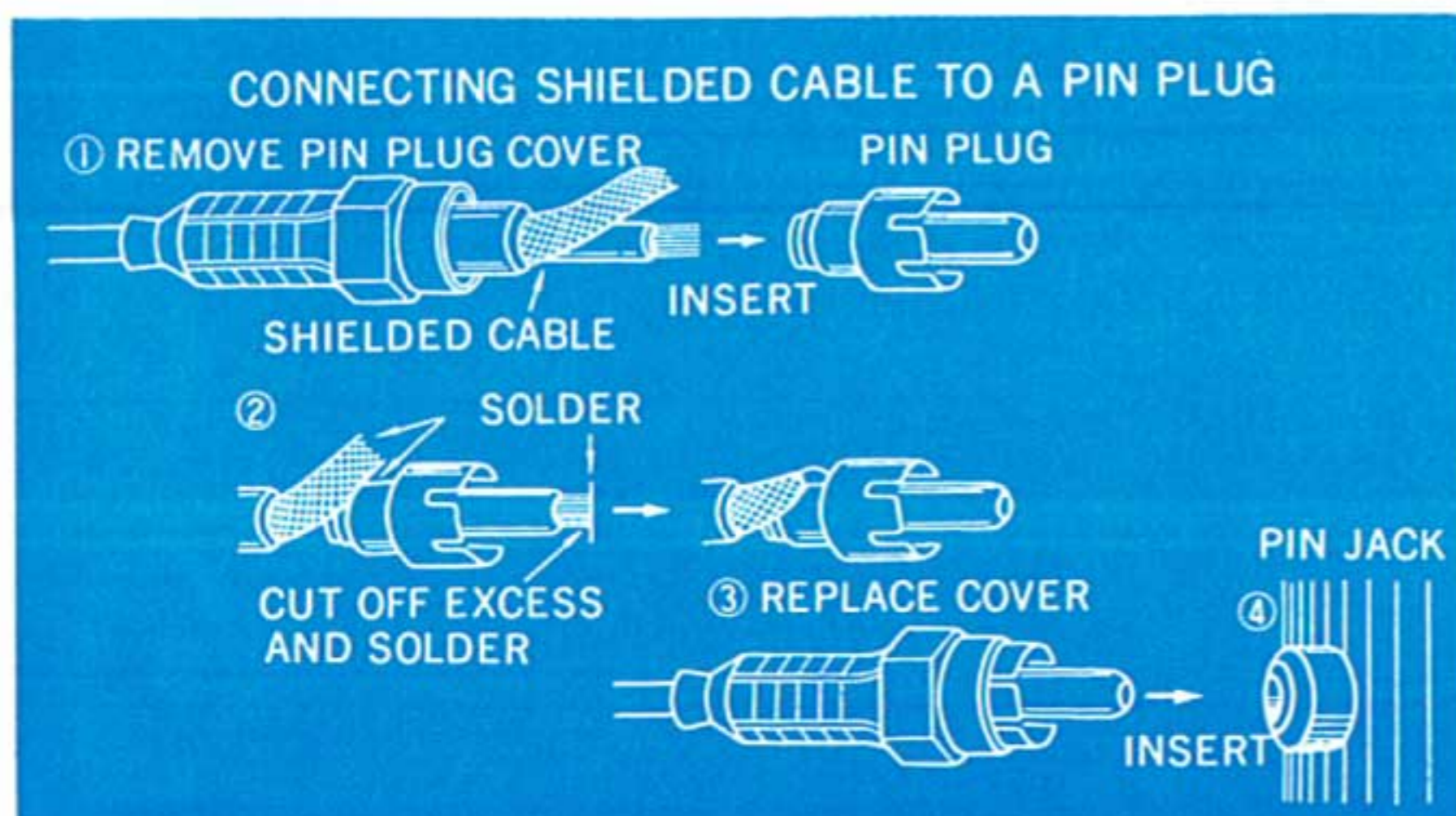

Speaker Impedance

Do not ever connect two pairs of speaker systems with impedance of less than 8 ohms each. Doing so will reduce the composite speaker impedance in each channel to less than 4 ohms, and may cause the quick-acting fuses to blow or result in a more serious breakdown over a long period of time.

Phasing of Speakers

Listen to any monophonic reproduction. If the speaker systems are correctly phased, the sound will seem to come from a point midway between the left and right speaker systems. If the sound is not directly in front of you, however, the speaker systems are out of phase. If you notice this condition, check the speaker connections once. To correct the condition, switch the amplifier off and reverse the connection of plus and minus leadwires of one speaker cable. Also, be careful not to connect a single speaker system between the SYSTEM-A and SYSTEM-B terminals by mistake.

Howling and Hum

Take care never to place a turntable on or too near a speaker system, or the vibration produced by the speaker system is transmitted and causes an oscillating phenomenon called howling. It is best to keep these components completely separated, but if this is impossible, place a thick cushion between them. Humming, in contrast, is a phenomenon caused by incomplete or incorrect turntable-amplifier connections. Should this occur, check to see if all connections are completely made and if the connecting cables are sufficiently thick. Hum noise may sometimes be eliminated by connecting the grounding lead of the turntable to the GND terminal on the amplifier's rear panel.

Voltage Adjustment

Your AU-7500 is adjusted in our factory to operate at the power supply voltage of your area. That voltage is indicated on the amplifier. Should you, after purchasing the amplifier, move to an area where the power supply voltage is different from the one indicated, adjust the amplifier's voltage selector plugs as follows:

1. Remove the two screws securing the name plate on the rear, then remove the name plate.
2. Set the arrow mark on the Main Voltage Selector Plug to the new voltage: 100, 110, 117, 127, 220, 230, 240 or 250 volts.
3. If the new voltage is indicated in red, set the arrow mark on the adjacent Sub Voltage Selector Plug to "RED". If it is indicated in white, however, set that arrow to "WHITE".
4. Change the power fuse as well whenever the power supply voltage has changed. For 100—127 volt operation, use a 3-ampere glass-tubed fuse. For 220—250 volt operation, use a 2-ampere one.
5. Where the power supply voltage considerably fluctuates, the Main Voltage Selector Plug may be reset to avoid unpleasant side effects of such fluctuation. Reset it to the voltage immediately higher than the peak of the fluctuation.

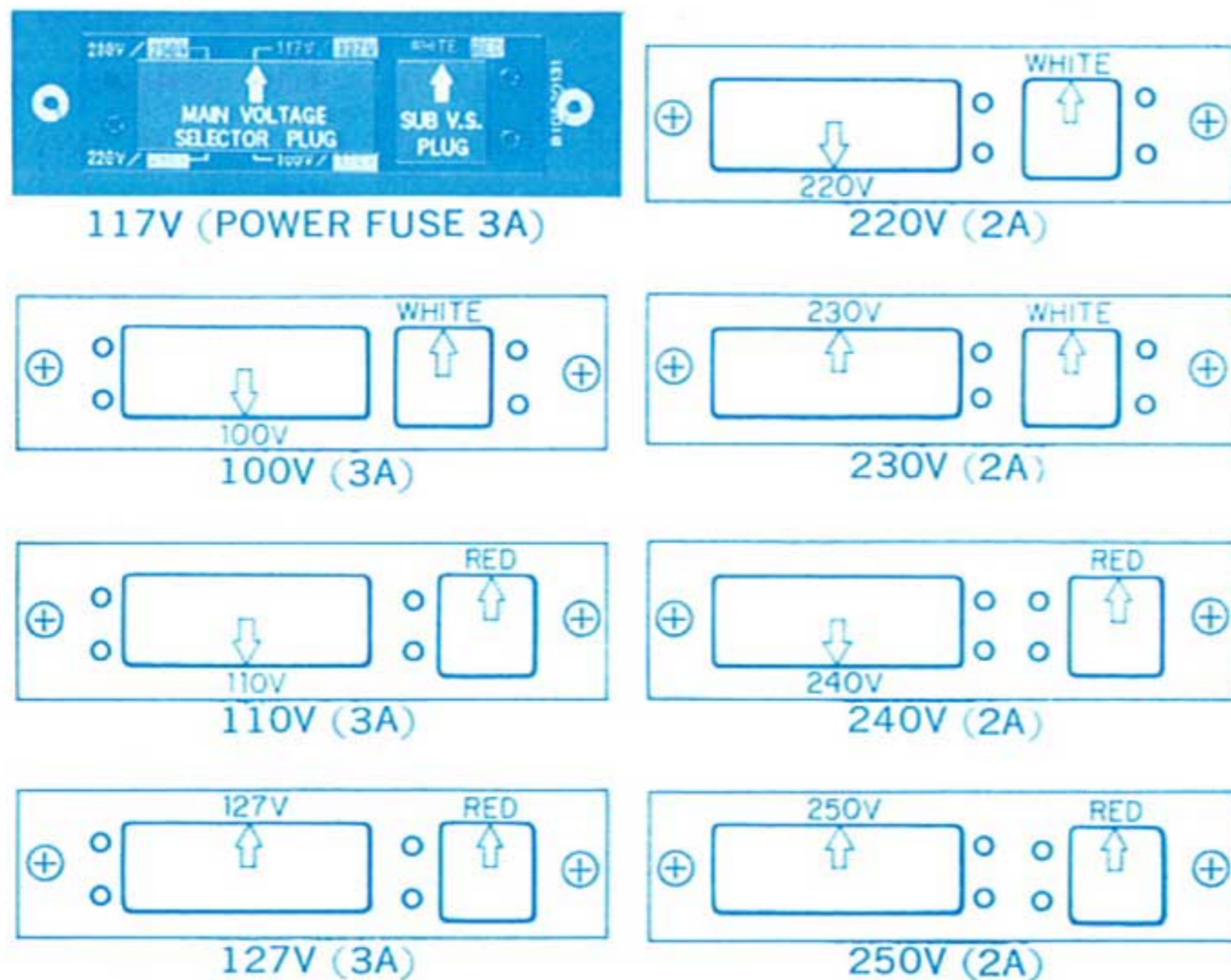

Heat Radiated inside the Amplifier

The bonnet of the AU-7500 is designed so that any heat radiated inside will effectively escape through it. Proper care should therefore be taken of the dissipation of such heat if you wish to place something on top of the amplifier or place it inside a closed box, etc. Above all, avoid placing it where it may be exposed to the direct sunlight.

It is prohibited, however, to remove the amplifier's bonnet or bottom plate to improve the ventilation.

Accessory List

1. OPERATING INSTRUCTIONS AND SERVICE MANUAL	1
2. OPERATING INSTRUCTIONS SHEET	1
3. PIN PLUGS	4
4. BUTTERFLY BOLTS	2
5. WASHERS	2
6. POLISHING CLOTH	1
7. QUICK-ACTING FUSES (4A).....	2

QUICK CHECK LIST OF SIMPLE MISTAKES

Some of the troubles which seem to result from a malfunction of the amplifier are caused by wrong operation and the negligence of simple maintenance, and can be quickly corrected by making a simple investigation and providing simple cures. To make sure you haven't made any of these mistakes, go over the following check list once.

Connections

1. Have you connected the power cord to a wall AC outlet?
2. Are the connecting cables for the turntable and tape deck not loose?
3. Are the speaker cables not loose from the amplifier's jacks or the speaker systems?
4. Do your speaker systems have impedance of 8 ohms or more? (They must, if you want to drive two pairs at one time.)
5. Have the power fuse or quick-acting fuses not blown?

Operating Procedure

1. Have you turned on the Power/Speakers Switch?
2. Is the Tape Monitor Switch not set to PLAY-BACK position, though you don't want to reproduce a tape?
3. Is the Selector Control set to the correct position?
4. Is the Power/Speakers Switch set to the correct position?
5. Is the 4-Channel Adaptor Switch not pushed down, though you are not using a 4-channel rear amplifier or adaptor?

If, even after these examinations, the amplifier does not return to normal, it may be faulty. Contact the Sansui dealer from whom you purchased the amplifier or your nearest Sansui Authorized Service Station. Do not attempt opening the bonnet for yourself. Such repair must be left to a qualified service man.

Should the Power Fuse Blow

If the amplifier simply remains dead even after you have turned on its Power/Speakers Switch, it is possible that its power fuse has blown.

If this happens, switch off the amplifier, disconnect the power cord from the wall AC outlet at once and examine the power fuse on the amplifier's rear panel. If you find it blown, replace it with a new glass-tubed fuse of the rated capacity (3-ampere for 100 to 127 volts, 2-ampere for 220 to 250 volts). Never use a fuse of a different capacity or a piece of wire, even as a stop-gap measure, or serious danger could result.

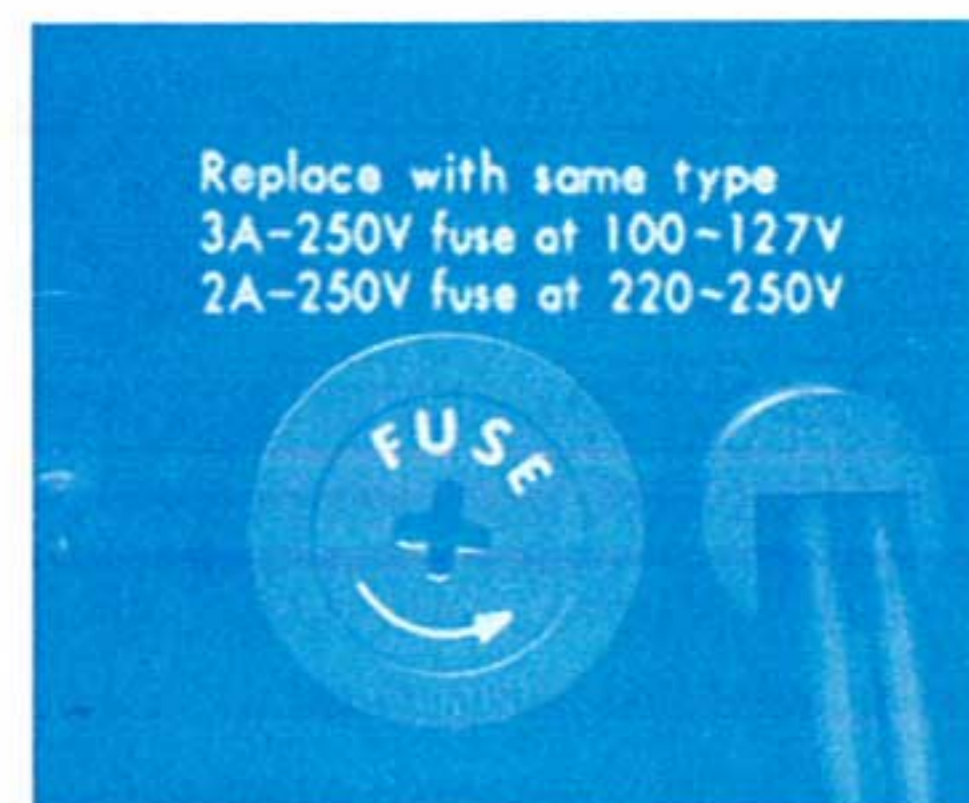

Quick-Acting Fuses

The AU-7500 is doubly protected with a relay-equipped protection circuit and four quick-acting fuses. If no sound or distorted sound is heard from either or both speaker systems, switch off the amplifier, disconnect the power cord from the wall AC outlet, remove the cover on the rear panel concealing the quick-acting fuses and examine them. If you find any of them blown, find and eliminate the cause of the blowout, then replace it with a new glass-tubed quick-acting fuse supplied.

If the relay-equipped protection circuit ever goes to work, the sound may come out intermittently. If it happens, check the connections of various equipment and your operating procedure once.

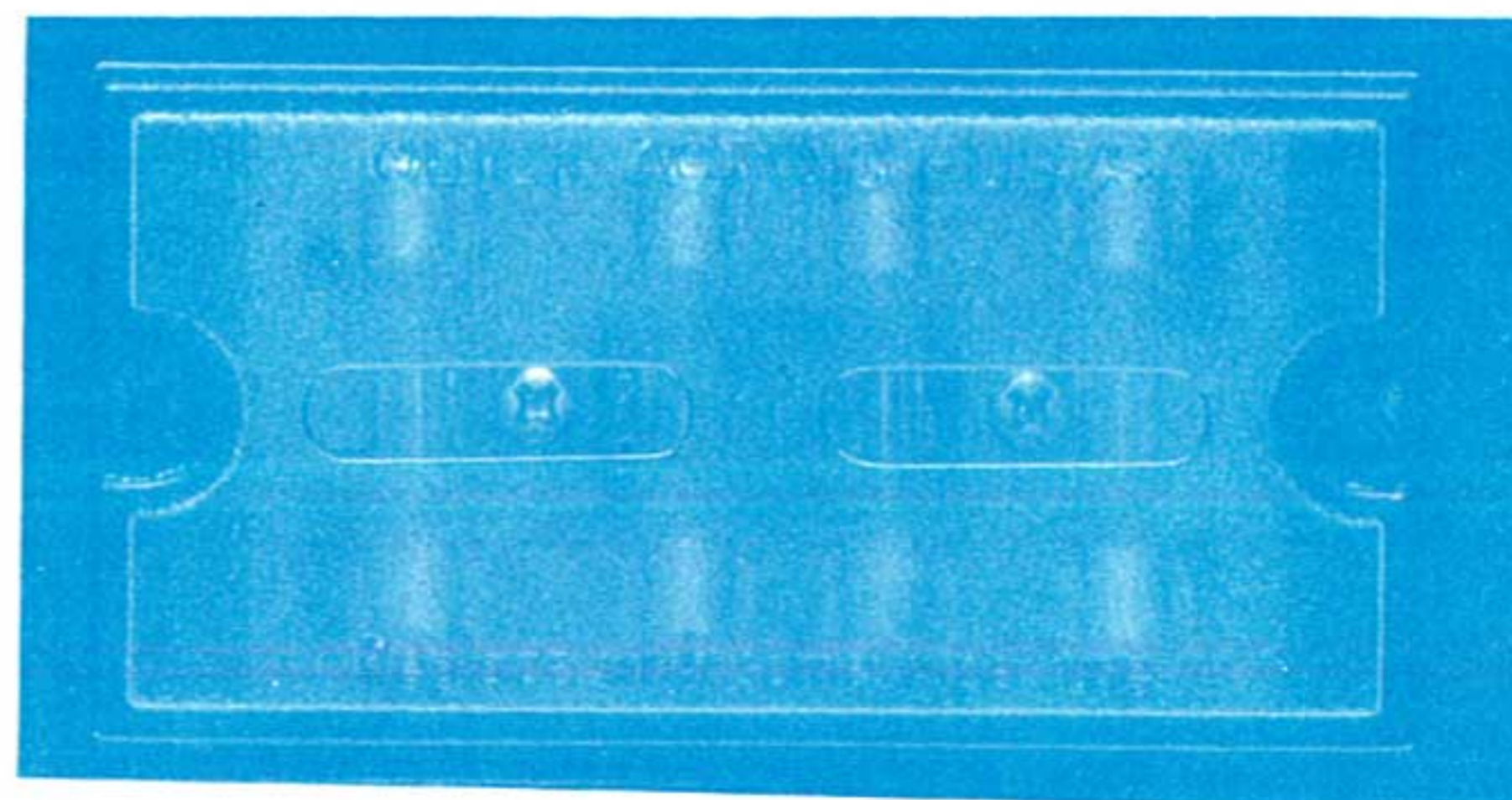

SPECIFICATIONS

POWER OUTPUT:

IHF MUSIC POWER	150W (4Ω, 1,000Hz)
CONTINUOUS RMS POWER (each channel driven)	43/43W (4Ω, 1,000Hz)
CONTINUOUS RMS POWER (both channels driven)	40+40W (8Ω, 1,000Hz)
CONTINUOUS RMS POWER (both channels driven at rated distortion, 20 to 20,000Hz)	32+32W (8Ω)

TOTAL HARMONIC DISTORTION:

less than 0.1% at rated output

INTERMODULATION DISTORTION

(70Hz : 7,000Hz=4 : 1 SMPTE method):

less than 0.1% at rated output

IHF POWER BANDWIDTH (each channel driven at 8Ω):

5 to 40,000Hz

FREQUENCY RESPONSE (at 1 watt power output):

PHONO-1 and 2	RIAA equalization curve
	±0.5dB (30 to 15,000Hz)
OVER-ALL (from AUX)	10 to 30,000Hz ±1.0dB
MAIN INPUT	10 to 50,000Hz ±1.0dB

LOAD IMPEDANCE:

4 to 16 ohms

DAMPING FACTOR:

approx. 40 at 8 ohms load

INPUT SENSITIVITY AND IMPEDANCE (at 1,000Hz):

PHONO-1	2.5mV (50kΩ)
PHONO-2	2.5mV (30kΩ, 50kΩ, 100kΩ)
Max. Input Capability	300mV (THD: less than 0.5%)
MIC	2.5mV (50kΩ)
TUNER	100mV (50kΩ)
AUX	100mV (50kΩ)
TAPE DECK-1 and 2 (Pin)	100mV (50kΩ)
TAPE DECK-2 (DIN)	100mV (50kΩ)
4-CH ADAPTOR	100mV (50kΩ)
MAIN INPUT	800mV (40kΩ)

OUTPUT VOLTAGE (at 1,000Hz):

TAPE DECK-1 and 2 (Pin)	100mV
TAPE DECK-2 (DIN)	30mV
4-CH ADAPTOR	100mV
PRE-OUTPUT	0.8V (THD: less than 0.08%)
Max. Output Voltage	4.0V (THD: less than 0.5%)

CROSSTALK (at rated output, 1,000Hz):

PHONO-1 and 2	better than 50dB
MIC	better than 50dB
TUNER	better than 50dB
AUX	better than 50dB
MAIN INPUT	better than 65dB

IHF HUM AND NOISE:

PHONO-1	better than 75dB
---------	------------------

PHONO-2	better than 75dB
MIC	better than 75dB
TUNER	better than 80dB
AUX	better than 80dB
MAIN INPUT	better than 100dB

CONTROLS & SWITCHES:

BASS	+15dB, -15dB at 50Hz
MIDRANGE	+5dB, -5dB at 1,500Hz
TREBLE	+15dB, -15dB at 15,000Hz
LOUDNESS	+10dB at 50Hz, +10dB at 15,000Hz (volume control at -30dB)
LOW FILTER	-12dB at 50Hz (12dB/oct)
HIGH FILTER	-11dB at 10,000Hz (12dB/oct)

SEMICONDUCTORS:

transistors 38, diodes 15
zener diode 1

POWER REQUIREMENTS:

100, 110, 117, 127, 220 30, 2,
240, 250V, 50/60Hz

POWER CONSUMPTION:

MAXIMUM	315VA
RATED	100W

DIMENSIONS:

140mm (5⁹/₁₆") H
440mm (17³/₈") W
322mm (12¹/₁₆") D

WEIGHT:

12.7kg (28.0 lbs.)

SCHEMATIC DIAGRAM



NOTES TO SERVICE ENGINEERS



■ Please contact the nearest Sansui Authorized Service Station for replacement parts. When ordering them, look up the part lists on pages 19 to 26 and let us know (1) the amplifier's model number, (2) name of the printed circuit board, (3) part No., (4) name of the part, and (5) its stock No. Using nonstandard parts for temporary relief often impairs the sound quality and over-all reliability of the amplifier. Please take the trouble to contact your nearest Sansui Authorized Service Station.

■ Consult pages 17 to 26 when making repairs or adjustments. To check or measure the amplifier performance, connect a load resistance of 4 to 16 ohms to the amplifier's speaker output terminals first. To check the electrical output characteristics, do not remove the bonnet and bottom plate.

GENERAL TROUBLESHOOTING CHART

PROGRAM SOURCE	SYMPTOM	PROBABLE CAUSE	WHAT TO DO
Tuner.	* Noise during AM reception.	<ul style="list-style-type: none"> * Interference by adjacent stations (called beat interference). * TV set is being used simultaneously. 	<ul style="list-style-type: none"> * Peculiar to AM waves, and unavoidable to some extent. * Move TV set away from tuner and amplifier.
	* Noise heard at certain hours, in certain areas or over part of dial during AM reception.	* Interference by nearby electrical appliances.	<ul style="list-style-type: none"> * Attach noise limiter to appliance producing noise. * In some cases, can be eliminated by reversing power cord plug-AC outlet connections.
	* Pop noise during FM reception.	* Ignition noise from nearby automobile, motorcycle, etc.	<ul style="list-style-type: none"> * Adjust antenna location and height for maximum sensitivity. * Keep antenna away from streets. <p>Note: In many cases, high-frequency noise during radio reception cannot be entirely eliminated. Try turning on amplifier's High Filter Switch or turning Treble Control counterclockwise.</p>
Turntable.	* Hum noise.	<ul style="list-style-type: none"> * Unshielded cables used to connect turntable. * Minus (ground) wire of connecting cable is not connected completely. * Turntable motor or tonearm is not grounded. 	<ul style="list-style-type: none"> * Use regular shielded cables. * Examine connecting cables, especially their plugs. * Connect grounding lead of turntable to amplifier's GND terminal.
	* Loud oscillating noise.	* Turntable is placed on top of or too close to speaker systems.	<ul style="list-style-type: none"> * Place thick cushion between turntable and speaker systems. * Change location of turntable and speaker systems. * If using microphone(s), move or direct them away from speaker systems
	* Sound is shaky.	<ul style="list-style-type: none"> * Dust on record or pickup stylus. * Worn pickup stylus. * Improper stylus pressure. 	<ul style="list-style-type: none"> * Clean record and pickup stylus. * Replace pickup stylus. * Adjust stylus pressure.
Tape Deck.	* Hiss noise.	* Magnetic heads are magnetized.	<ul style="list-style-type: none"> * Demagnetize heads. * Turn on High Filter Switch. * Connect noise reduction adaptor.
	* Sound is not clear.	<ul style="list-style-type: none"> * Dust on magnetic heads. * Tape is not pressed tight to heads. 	<ul style="list-style-type: none"> * Clean heads. * Align tape transport mechanism.
General.	* When left and right channel sound volumes are balanced with amplifier's Balance Control, it does not come to center position.	<ul style="list-style-type: none"> * Left and right channel signal strengths vary with program source. * Left and right speaker systems have different efficiencies. 	* Never mind. Optimum stereo effect is obtained by adjusting Balance Control so that sound comes from midway point between two speaker systems with Mode Switch set to MONO L+R.
	* Musical instruments and singer not located clearly.	* Left-right, plus-minus connections of speaker systems, input cables are wrong.	* Examine connections once.
	* Want to listen at very low volume level at night.	* Fine adjustment of very low volume cannot be done with Volume Control.	* Turn on Muting Switch, then adjust Volume Control.

DISASSEMBLY PROCEDURE

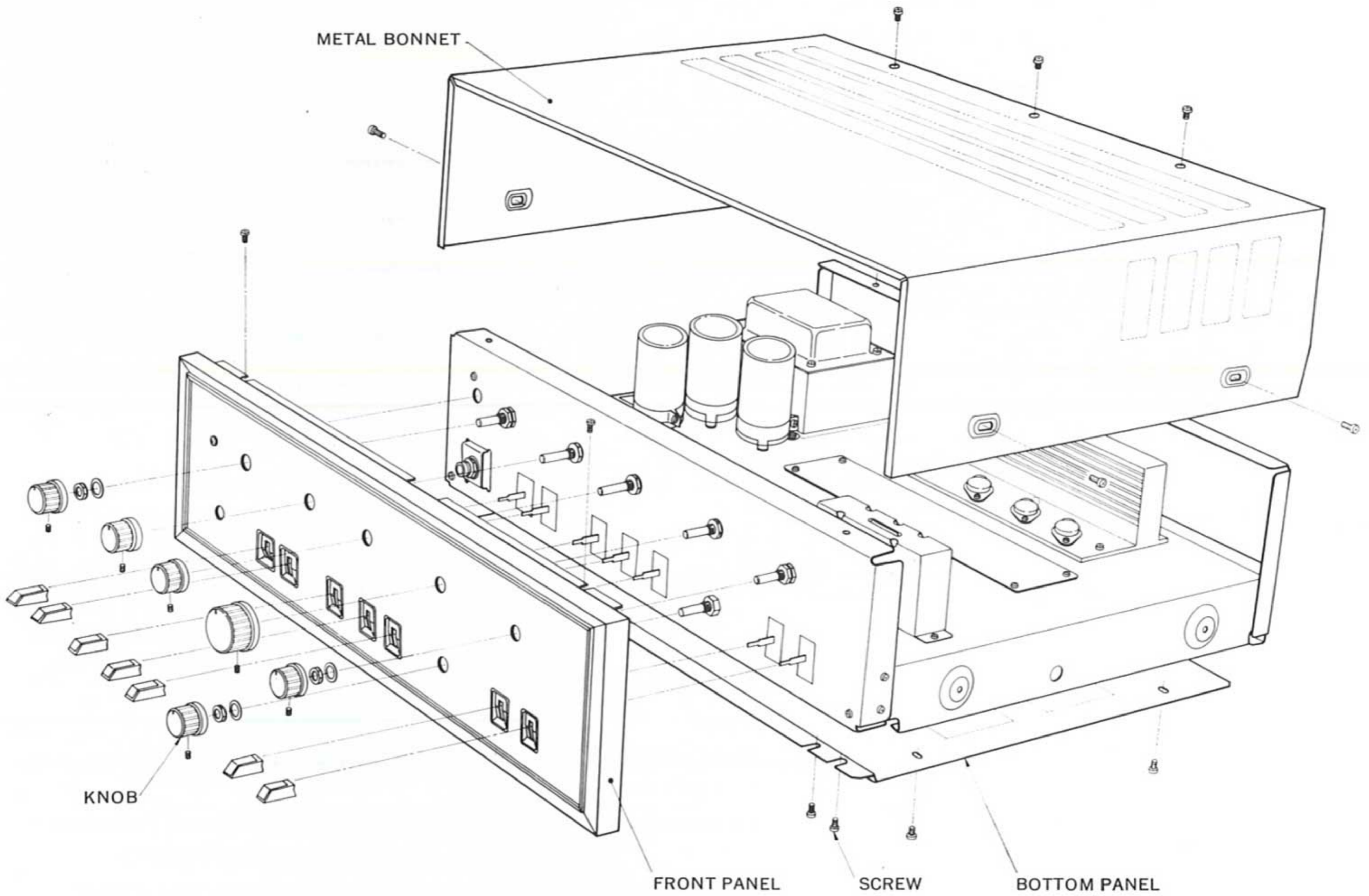

ALIGNMENT

Output of Power Amplifier Section

STEP	CONNECT/ADJUST	REMARKS
1.	Connect load resistance [8 to 16 ohms] to left (right) channel SYSTEM-A speaker terminals.	
2.	Connect voltmeter in parallel with load resistance.	Set voltmeter to 0.5V~3V range.
3.	Turn Power/Speakers Switch to SYSTEM-A.	
4.	Adjust VR ₈₀₁ (VR ₈₀₂) so that voltmeter indicates 0±50mA. Repeat above procedure for right channel (notations in parentheses are for right channel).	

Current Alignment of Power Amplifier Section

STEP	AMMETER (TESTER)	CONNECT/ADJUST	REMARKS
1.		Remove F ₀₀₂ and F ₀₀₃ .	Use ammeter with 100mA or 50mA range.
2.		Turn VR ₈₀₃ and VR ₈₀₄ fully counterclockwise.	
3.		Turn Power/Speakers Switch to SPKR OFF.	
4.	Set to 100mA range.	Connect ammeter where F ₀₀₂ was. (Connect (21) on schematic to minus terminal of ammeter, other end to plus terminal.)	
5.		Adjust VR ₈₀₃ (left channel) so that ammeter indicates 28 to 32mA.	
6.		Turn off Power/Speakers Switch and replace F ₀₀₂ .	
7.	Set to 100mA range.	Turn Power/Speakers Switch to SPKR OFF, then connect ammeter where F ₀₀₃ was. (Connect (22) on circuit schematic to minus terminal of ammeter, other end to plus terminal.)	
8.		Adjust VR ₈₀₄ (right channel) so that ammeter indicates 28 to 32mA.	
9.		Turn off Power/Speakers Switch and replace F ₀₀₃ .	

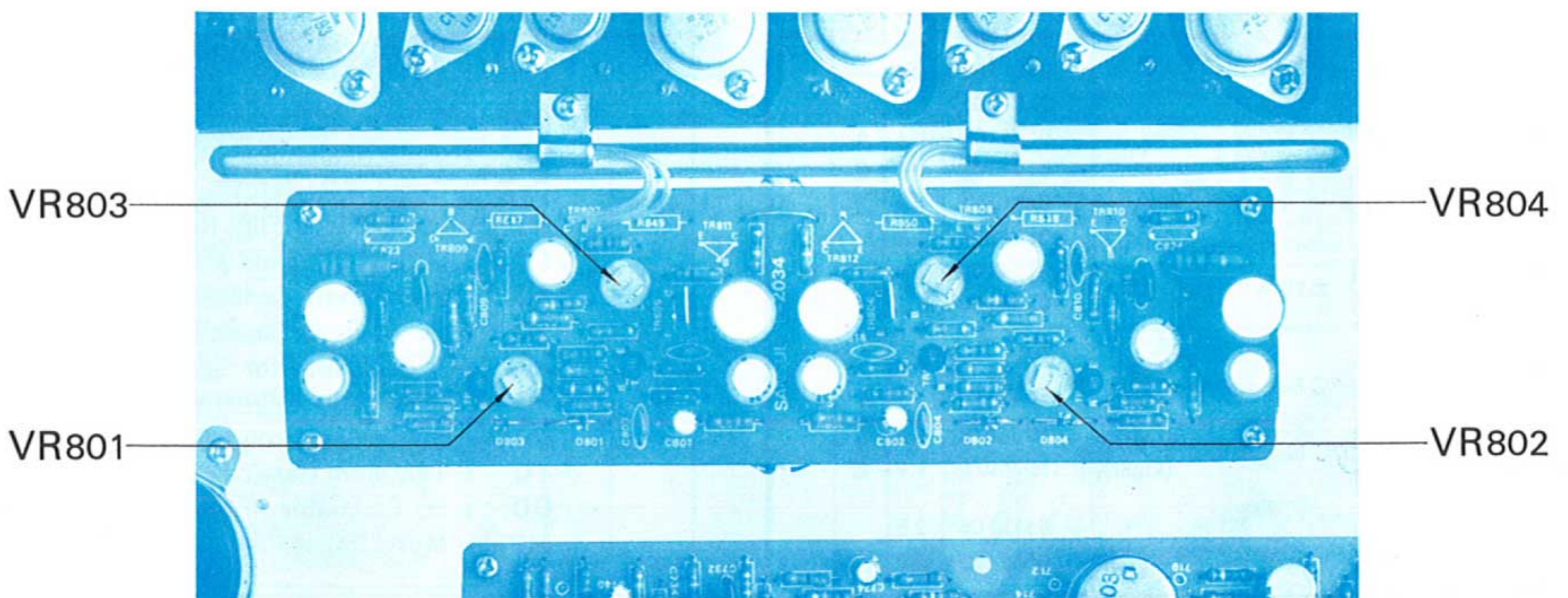

PRINTED CIRCUIT BOARDS AND PARTS LIST

W: Parts No. X: Parts Name Y: Stock No. Z: Position of Parts

DRIVER BLOCK <F-2034>

Stock No. 7570670

W	X	Y	Z
R801	330kΩ	0101334	2 B
R802	330kΩ	0101334	2 B
R803	10kΩ	0101103	2 B
R804	10kΩ	0101103	2 B
R805	47kΩ	0101473	2 A
R806	47kΩ	0101473	2 C
R807	27kΩ	0101273	2 A, B
R808	27kΩ	0101273	2 B, C
R809	18kΩ	0101183	2 A
R810	18kΩ	0101183	2 C
R811	3.3kΩ	0101332	2 A
R812	3.3kΩ	0101332	2 C
R813	100Ω	0101101	2 A
R814	100Ω	0101101	2 C
R815	100Ω	0101101	2 A
R816	100Ω	0101101	2 C
R817	18kΩ	0101183	2 A
R818	18kΩ	0101183	2 C
R819	1.8kΩ	0101182	2 A
R820	1.8kΩ	0101182	2 C
R821	47kΩ	0101473	1, 2 A
R822	47kΩ	0101473	1, 2 C
R823	220kΩ	0101224	1, 2 A
R824	220kΩ	0101224	1, 2 C
R825	3.3kΩ	0101332	2 A
R826	3.3kΩ	0101332	2 C
R827	2.2kΩ	0101222	1, 2 A
R828	2.2kΩ	0101222	1, 2 C
R829	4.7kΩ	0101472	1, 2 A
R830	4.7kΩ	0101472	1, 2 C
R831	220Ω	0101221	2 B
R832	220Ω	0101221	2 B
R833	1kΩ	0101102	1 B
R834	1kΩ	0101102	1 B
R835	3.3kΩ	0101332	2 A, B
R836	3.3kΩ	0101332	2 B, C
R837	39Ω	0101390	1 A
R838	39Ω	0101390	1 C
R839	180Ω	0101181	1 A
R840	180Ω	0101181	1 C
R841	100Ω	0101101	1 A
R842	100Ω	0101101	1 C
R843	100Ω	0101101	1 A, B
R844	100Ω	0101101	1 B, C
R845	390Ω	0101391	1 B
R846	390Ω	0101391	1 B
R851	10Ω	0104100	1 A
R852	10Ω	0104100	1 C
VR801	4.7kΩ(B)	1035110	2 A
VR802	4.7kΩ(B)	1035110	2 C
VR803	1kΩ(B)	1035070	1 A, B
VR804	1kΩ(B)	1035070	1 B, C
C801	4.7μF	0519106	2 B
C802	4.7μF	0519106	2 B

W	X	Y	Z
C803	47μF	0660470	2 B
C804	47μF	0660470	2 B
C805	47μF	0515470	2 A
C806	47μF	0515470	2 C
C807	47μF	0531470	2 A
C808	47μF	0531470	2 C
C809	3.3pF	0660339	1 A
C810	3.3pF	0660339	1 C
C811	47μF	0515470	1 A
C812	47μF	0515470	1 C
C813	0.068μF	0601687	1 A
C814	0.068μF	0601687	1 C
C815	100μF	0515101	1, 2 A
C816	100μF	0515101	1, 2 C
C817	22pF	0660220	2 B
C818	22pF	0660220	2 B
C819	220μF	0510221	2 B
C820	220μF	0510221	2 B
C821	100μF	0515101	1, 2 B
C822	100μF	0515101	1, 2 B
TR801	2SA493 (GR)	0300450	2 B
TR802		0300450	2 B
TR803		0300450	2 A
TR804		0300450	2 C
TR805	2SC1124 (2, 3)	0305901, 2	1, 2 B
TR806		0305901, 2	1, 2 B
TR807	2SC281 (B, C)	0305121, 2	1 A
TR808		0305121, 2	1 C
D801	1S1555	0311040	2 A
D802		0311040	2 C
D803		0311040	2 A
D804		0311040	2 C
	Printed Circuit Board F-2034	2570460	

Abbreviations

- CR** : Carbon Resistor
- SR** : Solid Resistor
- CeR** : Cement Resistor
- MFR** : Metal Oxide Film Resistor
- CC** : Ceramic Capacitor
- EC** : Electrolytic Capacitor
- SC** : Polystyrene Capacitor
- MC** : Mylar Capacitor
- MPC** : Metallized Polyester Capacitor
- BPEC** : Bipolar Electrolytic Capacitor
- TC** : Tantalum Capacitor
- OC** : Oil Capacitor
- MP** : Metal Paper Film Capacitor

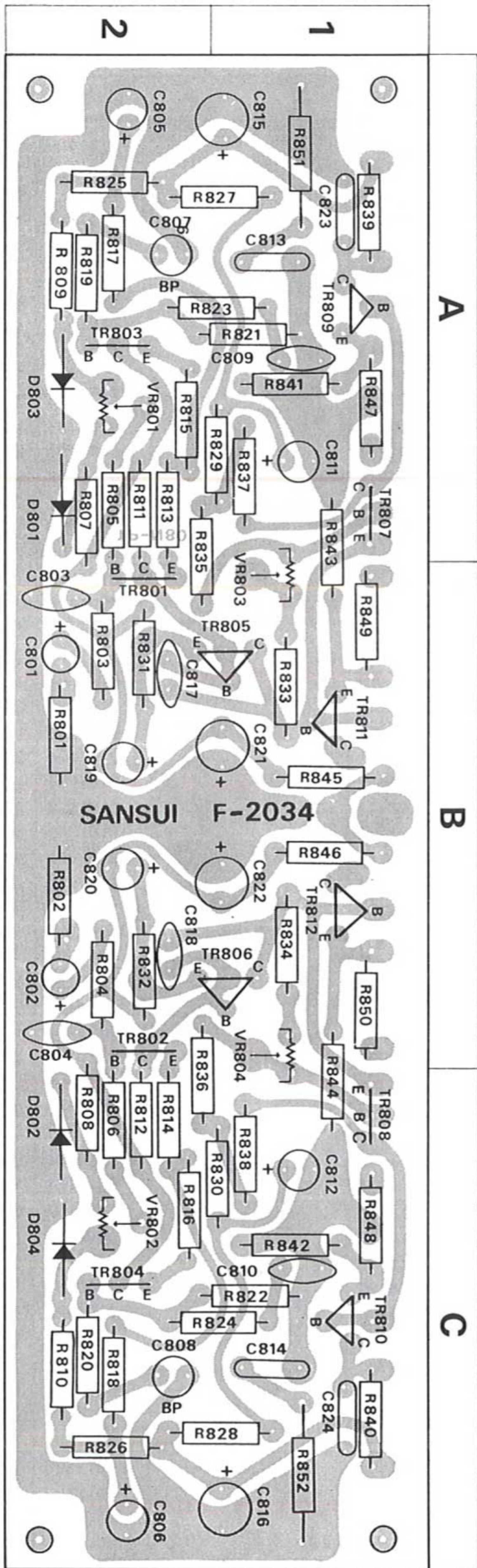

PROTECTOR BLOCK

<F-2041>

Stock No. 7591230

<F-1215A>

Stock No. 7591300

W	X	Y	Z
R001	2.2kΩ	0101222	B
R902	2.2kΩ	0101222	A
R903	47kΩ	0101473	A
R904	47kΩ	0101473	A
R905	68kΩ	0101683	B
R906	10Ω	0101100	B
R907	10Ω	0171100	A
R908	10Ω	0171100	A
R909	22kΩ	0107223	3C
R910	47kΩ	0107473	3C
C901	47μF	10V BPEC.	0531470 B
C902	220μF	6.3V EC.	0510221 B
C903	100μF	50V EC.	0515101 B
C904	0.1μF	±10% 50V MC.	0601108 A
C905	0.1μF		0601108 A
C906	1μF	50V EC.	0515109 B
C907	1μF	50V BPEC.	0535109 B
C908	220μF	35V EC.	0514222 3C
C909	0.047μF	+80% -20% 50V CC.	0657473 3C
TR901	2SC634A (6, 7, 8)	0305891,2,3	B
TR902		0305891,2,3	B
TR903		0305890,1,2	3C
D901	IN34A (K)	0310402	B
D902		0310402	B
D903		0310402	B
D904		0310402	B
D905		0310340	B
D906	10D-1	0310340	B
RL901	Relay	1150101	A
	Printed Circuit Board	F-2041	2591230
		F-1215	2590230

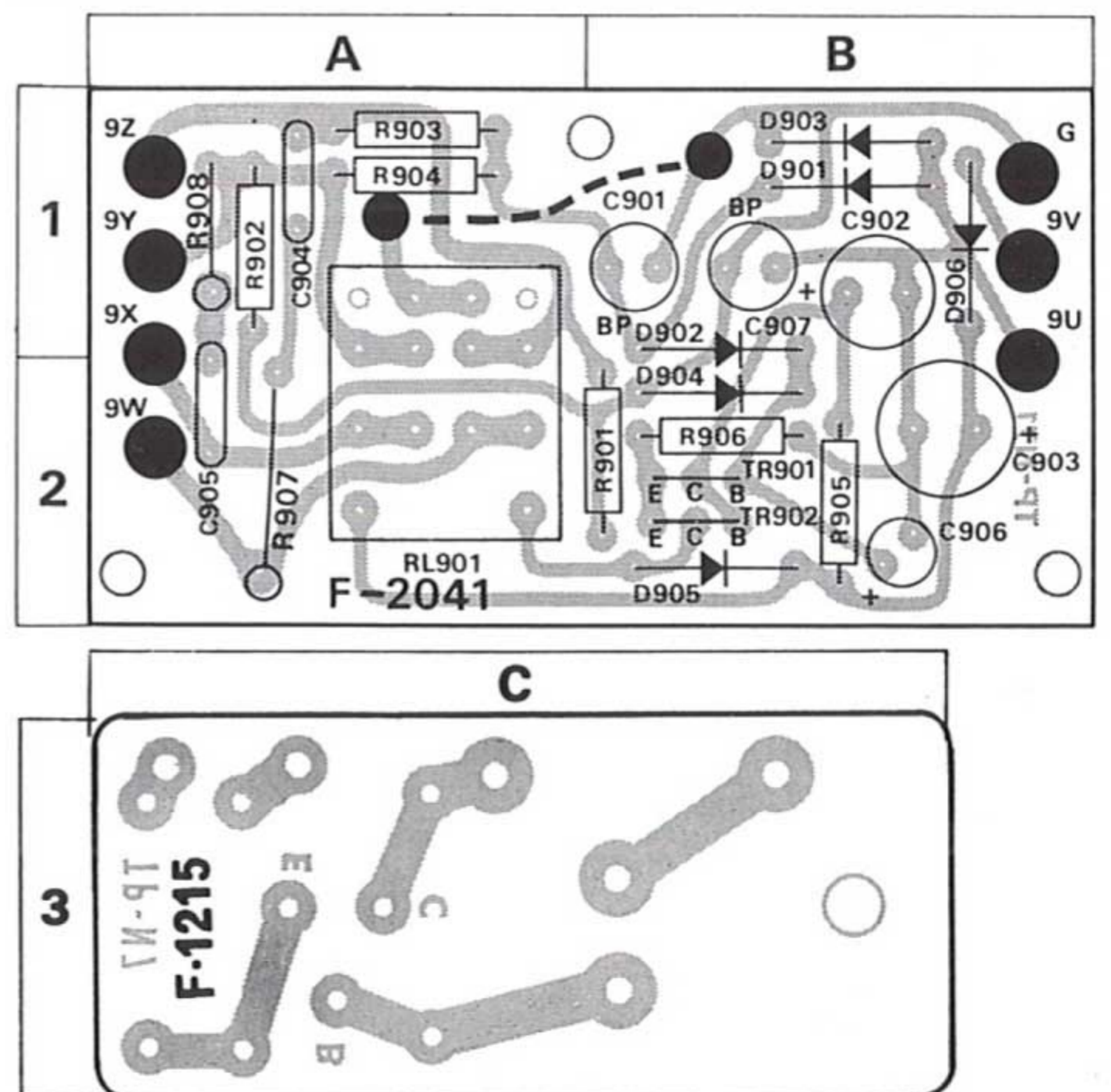

PRINTED CIRCUIT BOARDS AND PARTS LIST

W: Parts No. X: Parts Name Y: Stock No. Z: Position of Parts

TONE CONTROL BLOCK <F-2014>

Stock No. 7560570

W	X	Y	Z
R701	1kΩ	0101102	2 A
R702	1kΩ	0101102	1 A
R703	270kΩ	0101274	2 A
R704	270kΩ	0101274	1 A
R705	470kΩ	0101474	2 A
R706	470kΩ	0101474	1 A
R707	390kΩ	0101394	2 A
R708	390kΩ	0101394	1 A
R709	12kΩ	0101123	2 A
R710	12kΩ	0101123	1 A
R711	1kΩ	0101102	2 A
R712	1kΩ	0101102	1 A
R713	12kΩ	0101123	2 A
R714	12kΩ	0101123	1 A
R715	6.8kΩ	0101682	2 A
R716	6.8kΩ	0101682	1 A
R717	18kΩ	0101183	2 A
R718	18kΩ	0101183	1 A
R719	220Ω	0101221	2 A
R720	220Ω	0101221	1 A
R721	820Ω	0101821	2 A
R722	820Ω	0101821	1 A
R723	12kΩ	0101123	2 A
R724	12kΩ	0101123	1 A
R725	3.9kΩ	0101392	2 A
R726	3.9kΩ	0101392	1 A
R727	1kΩ	0101102	2 A
R728	1kΩ	0101102	1 A
R729	12kΩ	0101123	2 A, B
R730	12kΩ	0101123	1 A, B
R731	3.9kΩ	0101392	2 B
R732	3.9kΩ	0101392	1 B
R733	1kΩ	0101102	2 B
R734	1kΩ	0101102	1 B
R735	3.3kΩ	0101332	2 A, B
R736	3.3kΩ	0101332	1 A, B
R737	12kΩ	0101123	2 B
R738	12kΩ	0101123	1 B
R739	12kΩ	0101123	2 B
R740	12kΩ	0101123	1 B
R741	470Ω	0101471	2 B
R742	470Ω	0101471	1 B
R743	68kΩ	0101683	2 B
R744	68kΩ	0101683	1 B
R745	390kΩ	0101394	2 B
R746	390kΩ	0101394	1 B
R747	5.6kΩ	0101562	2 B
R748	5.6kΩ	0101562	1 B
R749	560Ω	0101561	2 B
R750	560Ω	0101561	1 B
R751	150kΩ	0101154	2 B
R752	150kΩ	0101154	1 B
R753	820Ω	0101821	2 B, C
R754	820Ω	0101821	1 B, C
R755	6.8kΩ	0101682	2 C
R756	6.8kΩ	0101682	1 C

±10% 1/4W CR.

W	X	Y	Z
R757	22Ω	0101220	2 B
R758	22Ω	0101220	1 B
R759	56kΩ	0101563	2 B, C
R760	56kΩ	0101563	1 B, C
R761	39kΩ	0101393	2 B, C
R762	39kΩ	0101393	1 C
R763	1.5kΩ	0101152	2 C
R764	1.5kΩ	0101152	1 C
R765	270kΩ	0101274	2 C
R766	270kΩ	0101274	1 C
R767	39kΩ	0101393	2 C
R768	39kΩ	0101393	1 C
R769	10kΩ	0101103	2 C
R770	10kΩ	0101103	1 C
R771	10kΩ	0101103	2 C
R772	10kΩ	0101103	1 C
R773	1kΩ	0101102	2 C
R774	1kΩ	0101102	1 C
R775	470kΩ	0101474	2 C
R776	470kΩ	0101474	1 C
R777	100kΩ	0101104	2 C
R778	100kΩ	0101104	1 C
R779	82kΩ	0101823	2 C
R780	82kΩ	0101823	1 C
R781	100kΩ	0101104	2 C
R782	100kΩ	0101104	1 C
R783	6.8kΩ	0101682	2 C
R784	6.8kΩ	0101682	1 C
R785	47kΩ	0101473	2 C
R786	47kΩ	0101473	1 C
C701	0.22μF	0601228	2 A
C702	0.22μF	0601228	1 A
C703	47μF	0511470	2 A
C704	47μF	0511470	1 A
C705	22pF	0660220	2 A
C706	22pF	0660220	1 A
C707	33μF	0511330	2 A
C708	33μF	0511330	1 A
C709	4.7μF	0519106	2 A
C710	4.7μF	0519106	1 A
C711	0.01μF	0600107	2 A
C712	0.01μF	0600107	1 A
C713	0.01μF	0600107	2 A
C714	0.01μF	0600107	1 A
C715	0.0047μF	0600476	2 B
C716	0.0047μF	0600476	1 B
C717	0.008μF	0600806	2 B
C718	0.008μF	0600806	1 B
C719	1μF	0519101	2 B
C720	1μF	0519101	1 B
C721	10μF	0512100	2 B
C722	10μF	0512100	1 B
C723	4.7μF	0519106	2 B
C724	4.7μF	0519106	1 B

±10% 1/4W CR.

±10% 50V MC.

16V EC.

±10% 50V CC.

16V EC.

50V EC.

±5% 50V MC.

50V EC.

16V EC.

W	X	Y	Z
C727	47pF } ±10% 50V CC.	0660470	2 B, C
C728		0660470	1 B, C
C729	1 μF } 50V EC.	0519101	2 B, C
C730		0519101	1 B, C
C731	0.033 μF	0600337	2 C
C732	0.033 μF	0600337	1 C
C733	0.022 μF } ± 5% 50V MC.	0600227	2 C
C734		0600227	1 C
C735	0.0022 μF	0600226	2 C
C736	0.0022 μF	0600226	1 C
C737	2700pF } ± 5% 50V SC.	0610272	2 C
C738		0610272	1 C
C739	1 μF	0519101	2 C
C740	1 μF	0519101	1 C
C741	4.7 μF } 50V EC.	0519106	2 C
C742		0519106	1 C
C743	220 μF	0515221	1, 2 C
L701	Peaking Coil	4010030	2 A, B
TR701	2SA493 (GR)	0300450	1, 2 A
TR702		0300450	1 A
TR703	2SC1000 (GR)	0305880	2 A
TR704		0305880	1 A
TR705	2SA493 (GR)	0300450	2 B
TR706		0300450	1 B
TR707	0300450	2 C	
TR708	0300450	1 C	
TR709	0300450	2 C	
TR710	0300450	1 C	
Printed Circuit Board F-2014		2560530	

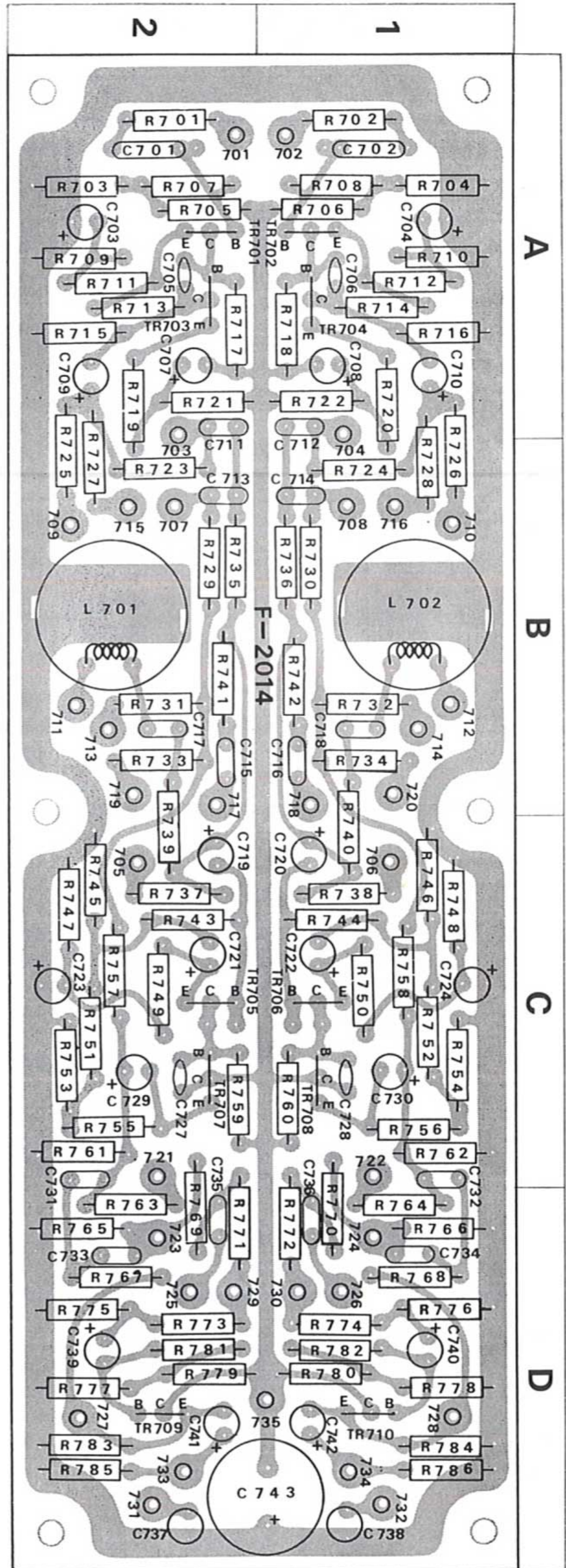

PRINTED CIRCUIT BOARDS AND PARTS LIST

W: Parts No. X: Parts Name Y: Stock No. Z: Position of Parts

EQUALIZER BLOCK <F-2028>

Stock No. 7550420

W	X	Y	Z
R601	100kΩ	0100104	2 B
R602	100kΩ	0100104	2 A
R603	47kΩ	0100473	1 B
R604	47kΩ	0100473	1 A
R605	120kΩ	0100124	1 B
R606	120kΩ	0100124	1 A
R607	100kΩ	0100104	1 B
R608	100kΩ	0100104	1 A
R609	100kΩ	0100104	1 B
R610	100kΩ	0100104	1 A
R611	2.2kΩ	0100222	1 B
R612	2.2kΩ	0100222	1 A
R613	220Ω	0100221	1 B
R614	220Ω	0100221	1 A
R615	22kΩ	0100223	1, 2 B
R616	22kΩ	0100223	1 A
R617	100kΩ	0100104	1 B
R618	100kΩ	0100104	1 A
R619	560Ω	0100561	1 B
R620	560Ω	0100561	1 A
R621	560Ω	0100561	1, 2 B
R622	560Ω	0100561	1, 2 A
R623	1.2kΩ	0100122	2 B
R624	1.2kΩ	0100122	2 A
R625	820Ω	0100821	1 B
R626	820Ω	0100821	1 A
R627	68kΩ	0100683	1 B
R628	68kΩ	0100683	1 A
R629	820kΩ	0100824	1, 2 B
R630	820kΩ	0100824	1, 2 A
R631	6.8kΩ	0100682	2 B
R632	6.8kΩ	0100682	2 A
R633	560Ω	0100561	2 B
R634	560Ω	0100561	2 A
R635	27kΩ	0100273	2 B
R636	27kΩ	0100273	2 A
R637	560kΩ	0100564	2 B
R638	560kΩ	0100564	2 A
R639	39kΩ	0100393	2 A
R640	39kΩ	0100393	2 A
R641	68kΩ	0100683	2 B
R642	68kΩ	0100683	2 A
R643	1.5kΩ	0100152	2 B
R644	1.5kΩ	0100152	2 A
C601	2.2μF	0573229	1 B
C602	2.2μF	0573229	1 A
C603	10μF	0513100	1 B
C604	10μF	0513100	1 A
C607	150pF	0660151	1 B
C608	150pF	0660151	1 A
C609	47μF	0512470	1 B
C610	47μF	0512470	1 A
C611	33μF	0511330	2 B
C612	33μF	0511330	2 A
C613	47pF	0660470	1 B
±10% ¼W CR.			

W	X	Y	Z
C614	47pF ±10% 50V CC.	0660470	1 A
C615	390pF	0610391	2 B
C616	390pF ±5% 50V SC.	0610391	2 A
C617	0.0022μF	0600226	2 B
C618	0.0022μF ±5% 50V MC.	0600226	2 A
C619	220pF	0610221	2 B
C620	220pF ±5% 50V SC.	0610221	2 A
C621	0.008μF	0600806	2 B
C622	0.008μF ±5% 50V MC.	0600806	2 A
C623	10μF	0515100	2 B
C624	10μF	0515100	2 A
C625	1μF	0519101	2 B
C626	1μF	0519101	2 A
C627	1500pF	0610152	2 B
C628	1500pF ±5% 50V SC.	0610152	2 A
TR601	2SA493 (GR)	0300450	1 B
TR602		0300450	1 A
TR603	2SC1000 (GR)	0305880	2 B
TR604		0305880	2 A
TR605	2SA493 (GR)	0300450	2 B
TR606		0300450	2 A
Printed Circuit Board F-2028			2550330

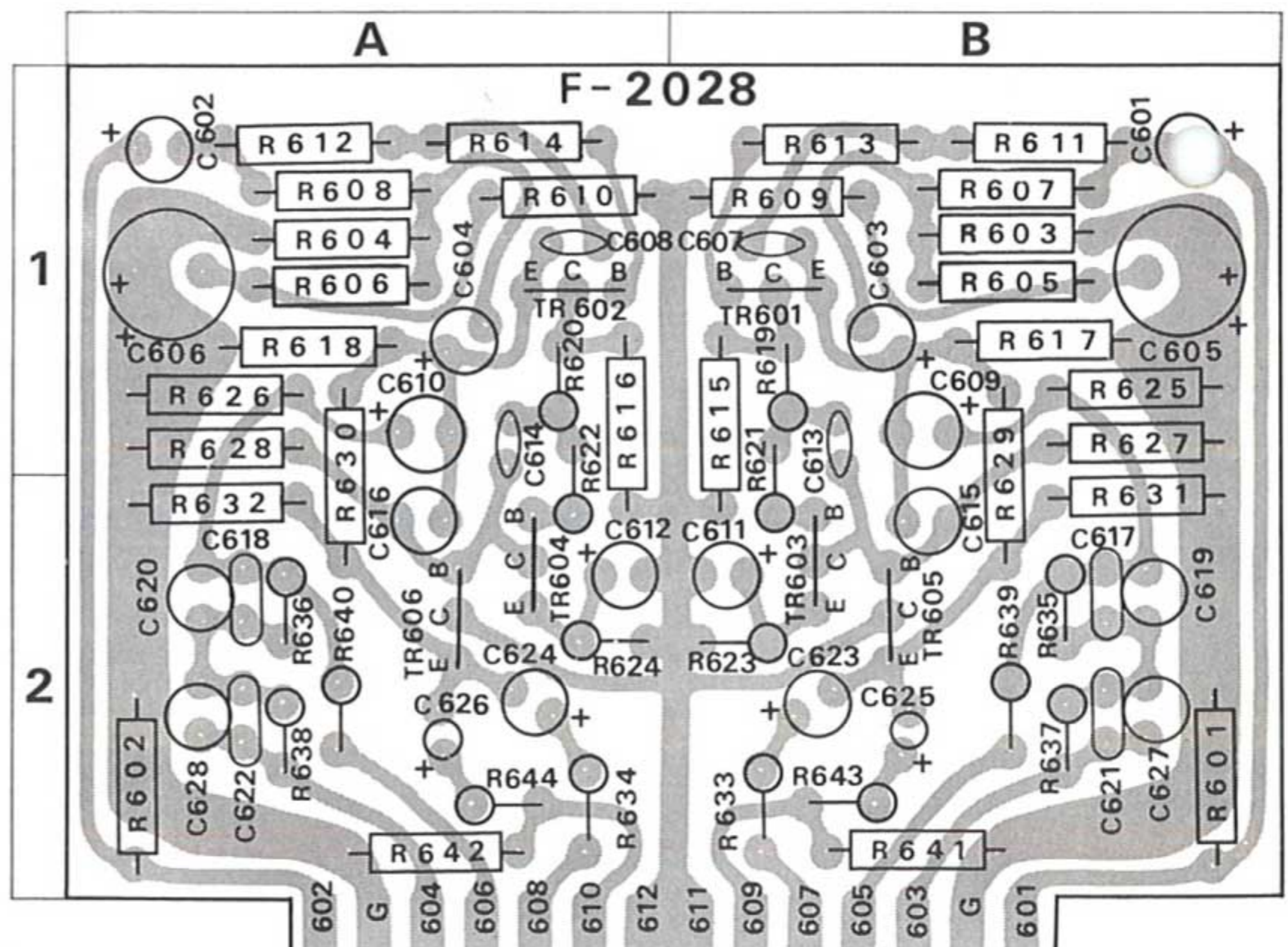

LOUDNESS BLOCK <F-2042>

Stock No. 7591240

W	X	Y	Z
R791	22kΩ } ±10% 1/4W CR.	0101223	
R792		0101223	
C751	390pF } ±5% 50V SC.	0610391	
C752		0610391	
C753	0.02μF } ±5% 50V MC.	0600207	
C754		0600207	
Printed Circuit Board F-2042		2591240	

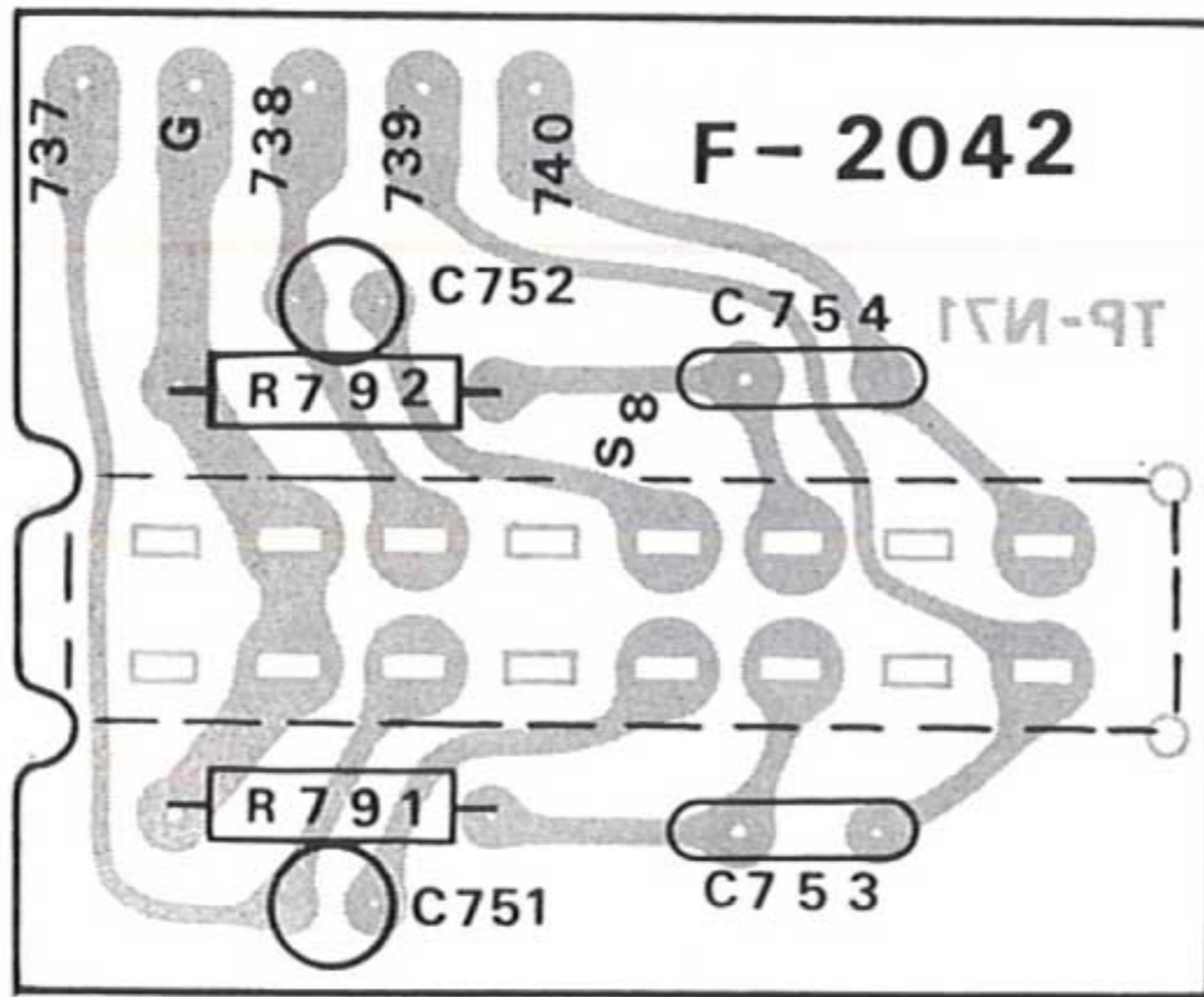

POWER SUPPLY BLOCK <F-2013-1>

Stock No. 7500690

W	X	Y	Z
R001	2.2kΩ	0101222	A
R002	18kΩ	0101183	A
R003	18kΩ	0101183	B
R004	1kΩ	0101102	A
R005	2.7kΩ	0101272	B
R006	33kΩ	0101333	B
R007	68kΩ	0101683	B
R008	100Ω	0103101	B
R009	390Ω	0103391	B
		±10% 1/2W CR.	
C009	4.7μF	63V EC.	0516479 A
C010	10μF	50V EC.	0515100 A
C011	0.047μF	+80% -20% 50V CC.	0657473 B
C012	10μF		0515100 B
C013	0.01μF	50V EC.	0515107 B
C014	220μF		0515221 B
TR001	2SB507 (C, D, E, F)		0303230,1,2,3 A
TR002	2SA678 (6, 7, 8)		0300291,2,3 B
TR003			0300291,2,3 B
ZD001	ZB-1-14		0315071 B
D002	10D-1		0310340 A
D003			0310340 A
D004			0310340 A
D005			0310340 A
			0310340 A
Printed Circuit Board F-2013-1		2500571	

SWITCH BLOCK <F-2023>

Stock No. 2591200

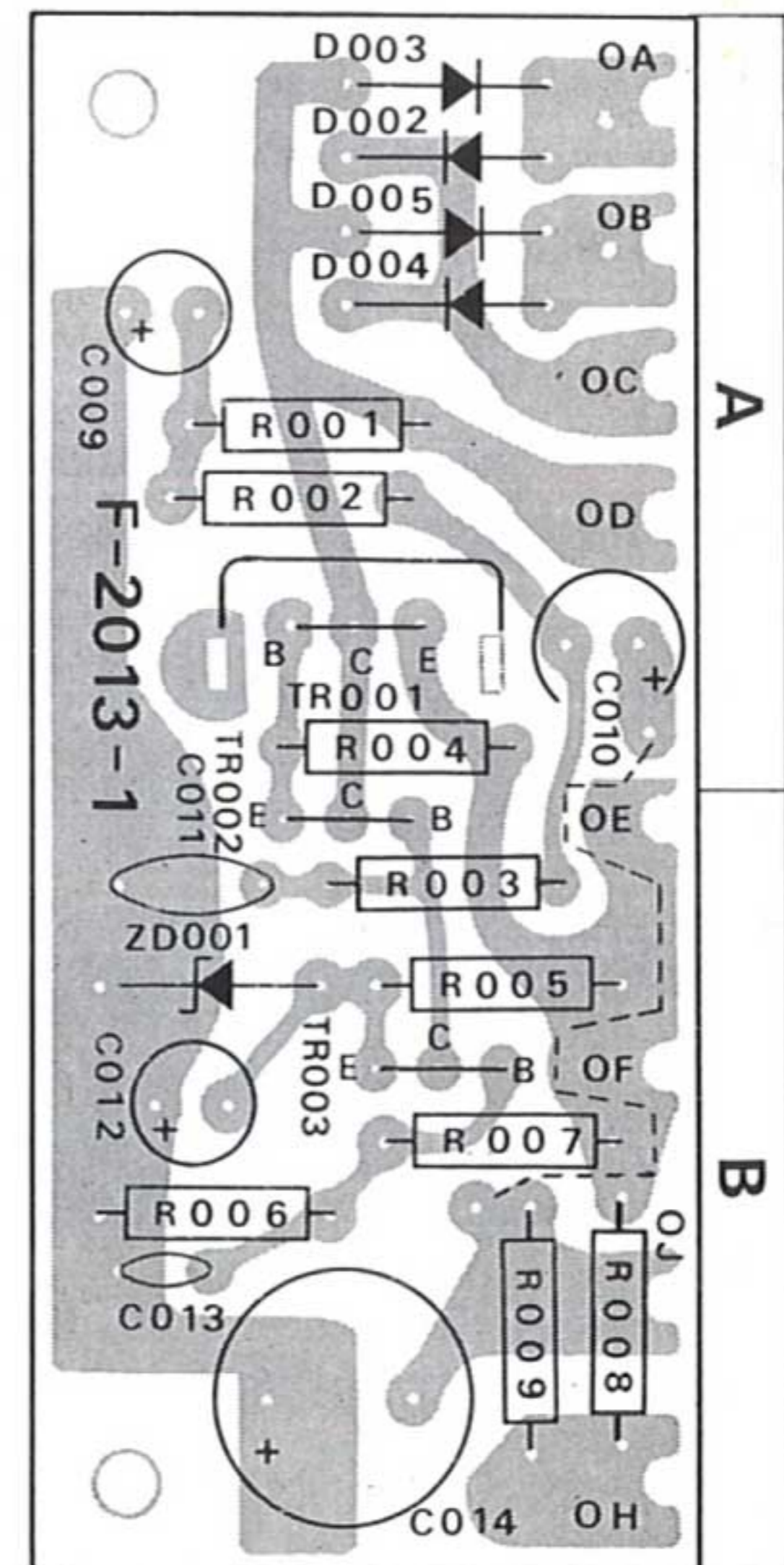
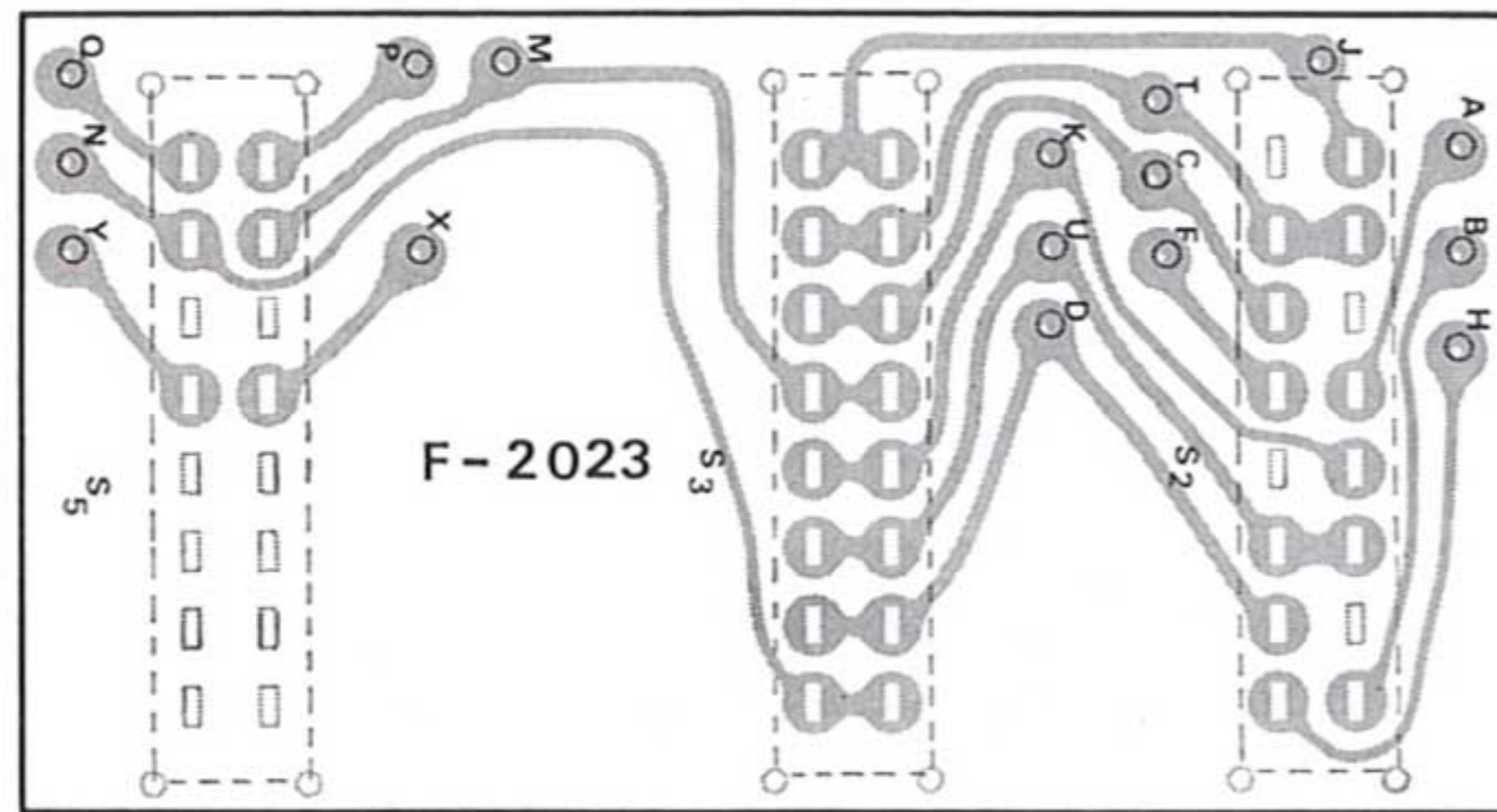

OTHER PARTS AND THEIR POSITION ON CHASSIS

W: Parts No. X: Parts Name Y: Stock No.

W	X	Y
R501	100kΩ	0101104
R502	100kΩ	0101104
R503	100kΩ	0101104
R504	100kΩ	0101104
R505	56kΩ	0101563
R506	56kΩ	0101563
R507	47kΩ	0101473
R508	47kΩ	0101473
R509	180kΩ	0101184
R510	180kΩ	0101184
R511	100kΩ	0101104
R512	100kΩ	0101104
R513	10kΩ	0101103
R514	10kΩ	0101103
R515	680kΩ	0101684
R516	680kΩ	0101684
R517	100kΩ	0101104
R518	100kΩ	0101104
R519	100kΩ	0101104
R520	100kΩ	0101104
R521	100kΩ	0101104
R522	100kΩ	0101104
R523	100kΩ	0101104
R524	100kΩ	0101104
R525	100kΩ	0101104
R526	100kΩ	0101104
R527	6.8kΩ	0107682
R528	6.8kΩ	0107682
R793	330kΩ	0101334
R794	330kΩ	0101334
R795	560kΩ	0101564
R796	560kΩ	0101564
R847	10Ω	0101100
R848	10Ω	0101100
R849	10Ω	0101100
R850	10Ω	0101100
R853	0.47Ω	0155478
R854	0.47Ω	0155478
R855	0.47Ω	0155478
R856	0.47Ω	0155478
R857	4.7Ω	0104479
R858	4.7Ω	0104479
R859	560Ω	0104561
R860	560Ω	0104561
R009	12kΩ	0104123
R010	5.6kΩ	0104562
R011	5.6kΩ	0104562
VR701	250kΩ (M, N) BALANCE	1010850
VR702		
VR703	250kΩ (B) × 2 VOLUME	1010850
VR704		
VR705	100kΩ (B) × 2 BASS	1010860
VR706		
VR707	100kΩ (B) × 2 MIDRANGE	1010860
VR708		
VR709	100kΩ (W) × 2 TREBLE	1010840
VR710		
C003	0.01μF ±10% 1.4kV CC.	0659801
C004	6800μF } 50V CC.	0515682
C005		6800μF } 0515682

W	X	Y
C006	0.22μF } ±10% 250V MP.	0592228
C007		0.22μF } 0592228
C008	2200μF 63V EC.	0559505
C011	0.022μF ±20% 250V MPC.	0605227
C014	1000μF 50V EC.	0559302
C501	0.047μF } ±10% 50V CC.	0660473
C502		0.047μF } 0660473
C803	0.047μF } 0660473	
C823	330pF } ±10% 50V CC.	0660331
C824		330pF } 0660331
TR809	2SC680 (A, B, C)	0305620,1,2
TR810		0305620,1,2
TR811	2SA566 (A, B, C)	0300150,1,2
TR812		0300150,1,2
TR813	2SC793 (R, Y, BL)	0305450,1,2
TR814		0305450,1,2
TR815	2SA663 (R, Y, BL)	0300350,1,2
TR816		0300350,1,2
	Power Transistor Socket (Big)	2030020
	Power Transistor Socket (Small)	2030030
D001	5B2	0310660
L801	Stabilizing Coil for High Frequency Range	4290221
L802		4290221
S1	SELECTOR	1105130
S2	TAPE TO TAPE REPRINT	1170290
S3	TAPE MONITOR	1170290
S4	PHONO 2 PICK-UP LOAD	1110110
S5	4CH ADAPTOR	1170300
S6	MODE SWITCH	1101190
S7	MUTING	1170270
S8	LOUDNESS	1170270
S9	LOW FILTER	1170270
S10	HIGH FILTER	1170270
S11	POWER/SPEAKERS	1101420
J501	MIC Jack	2430190
J502		2430190
J503	DIN Socket	2430040
J601	Multi-Connector (F-2028)	2420040
J801	HEADPHONES	2430220
T001	Power Transformer	4001150
CO001	AC Outlet (UNSWITCHED)	2450040
CO002	AC Outlet (SWITCHED)	2450040
CO003	AC Outlet (SWITCHED)	2450040
F001	Power Fuse (3A)	0433840
	Power Fuse Holder	2300060
F002	Quick-Acting Fuse (+ Power Supply, Lch.)	0433272
F003		(+ Power Supply, Rch.) 0433272
F004	4A (- Power Supply, Lch.)	0433272
F005		(- Power Supply, Rch.) 0433272
F01	1A } Wired-in Fuse	0432830
F02		1A } 0432830
F03		3A } 0432870
PL001	Power Indicator (6.3V 250mA)	0400090
	Power Indicator Socket	2320080
PU001	Voltage Selector	
	Main Plug	2410180
	Sub Plug	2410190
	Socket	2410170
	Printed Circuit Board for Protector Fuse F-1456	2598120

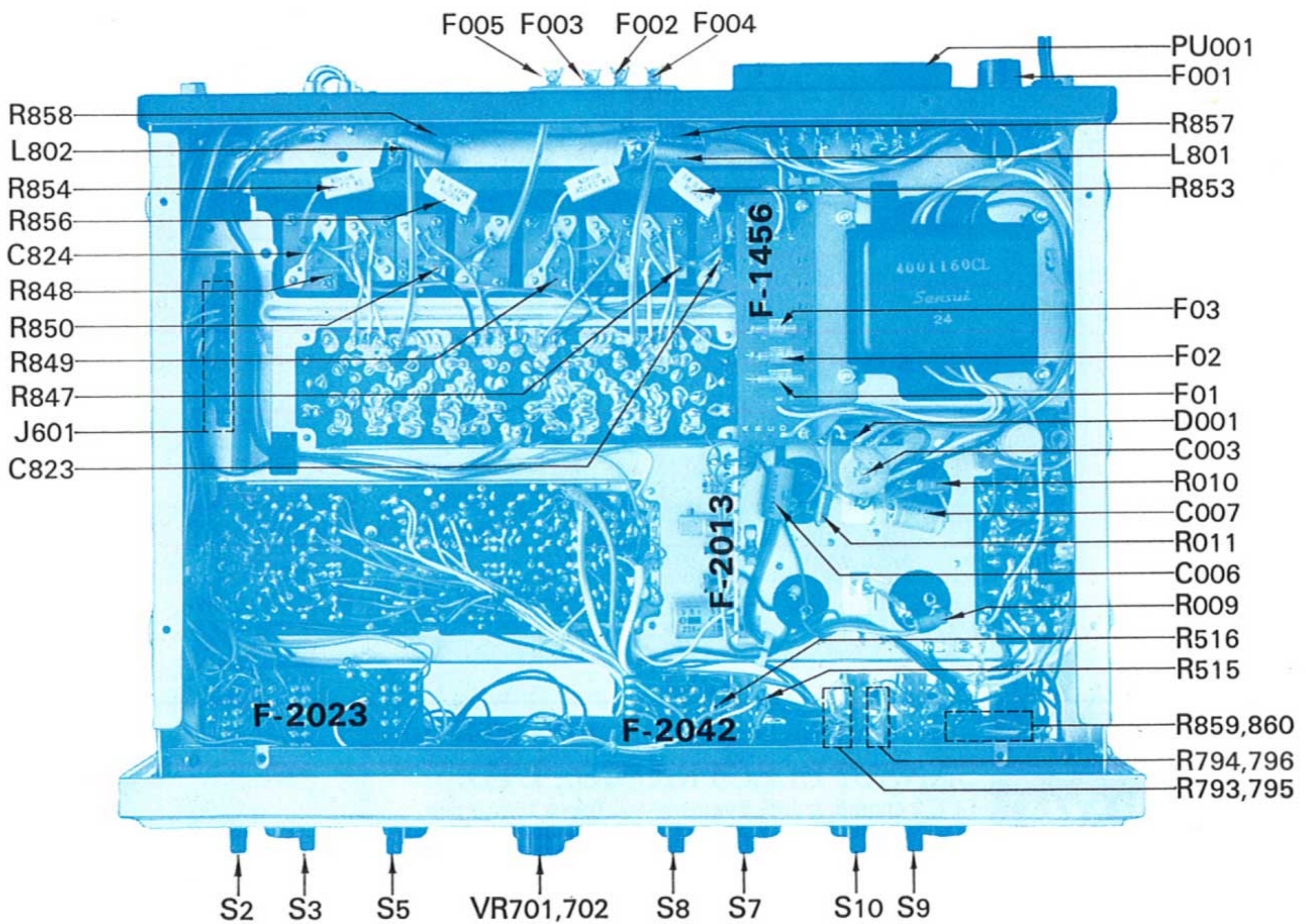
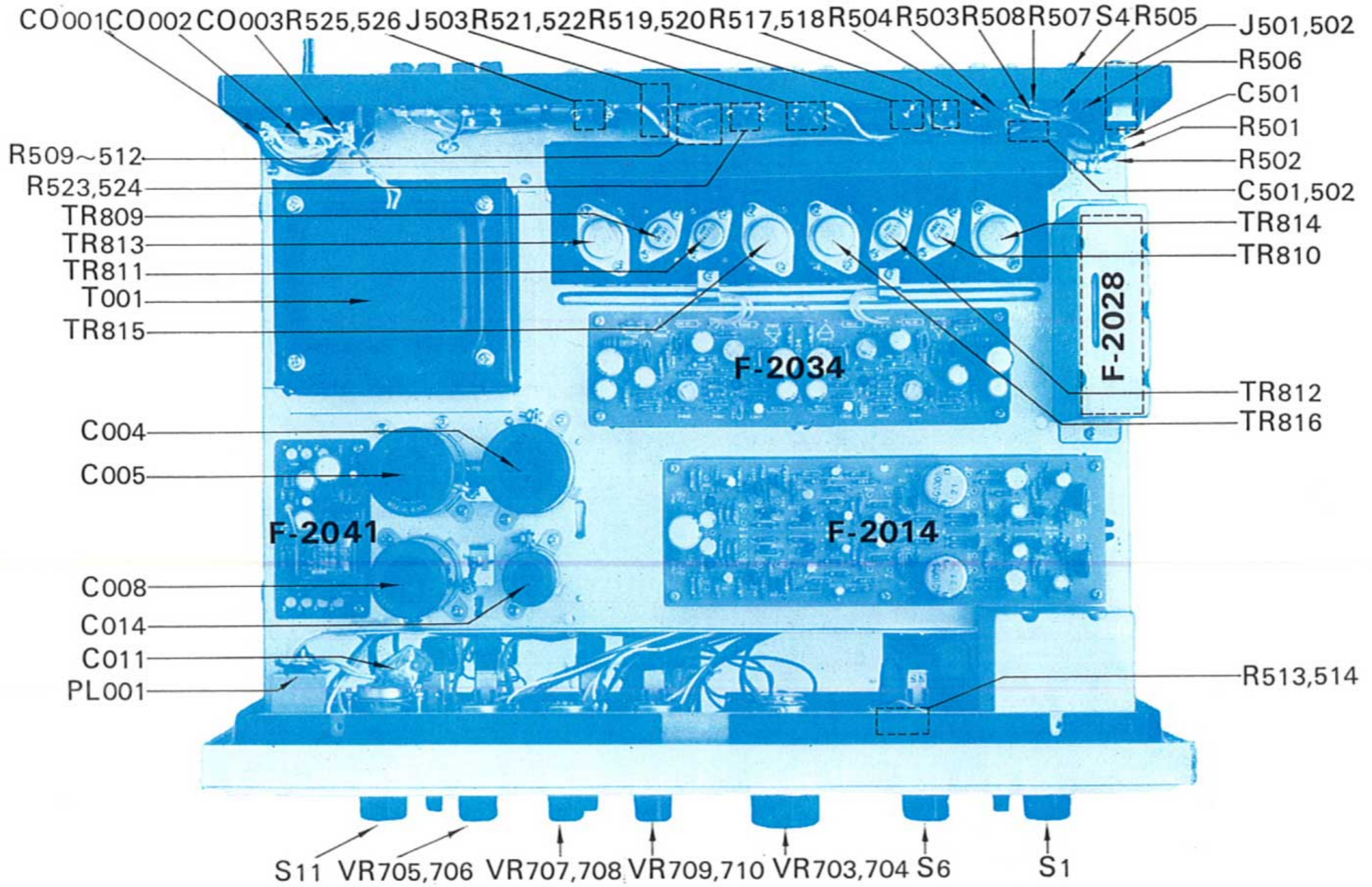



SANSUI ELECTRIC CO., LTD.

14-1, 2-chome, Izumi, Suginami-ku, Tokyo 168, Japan.
TELEPHONE: (03) 323-1111 / TELEX: 232-2076

Stock No. 9206960

Printed in Japan (82010M)