

# CITATION<sup>®</sup> ELEVEN

PROFESSIONAL SOLID STATE STEREOPHONIC PREAMPLIFIER/AUDIO EQUALIZER

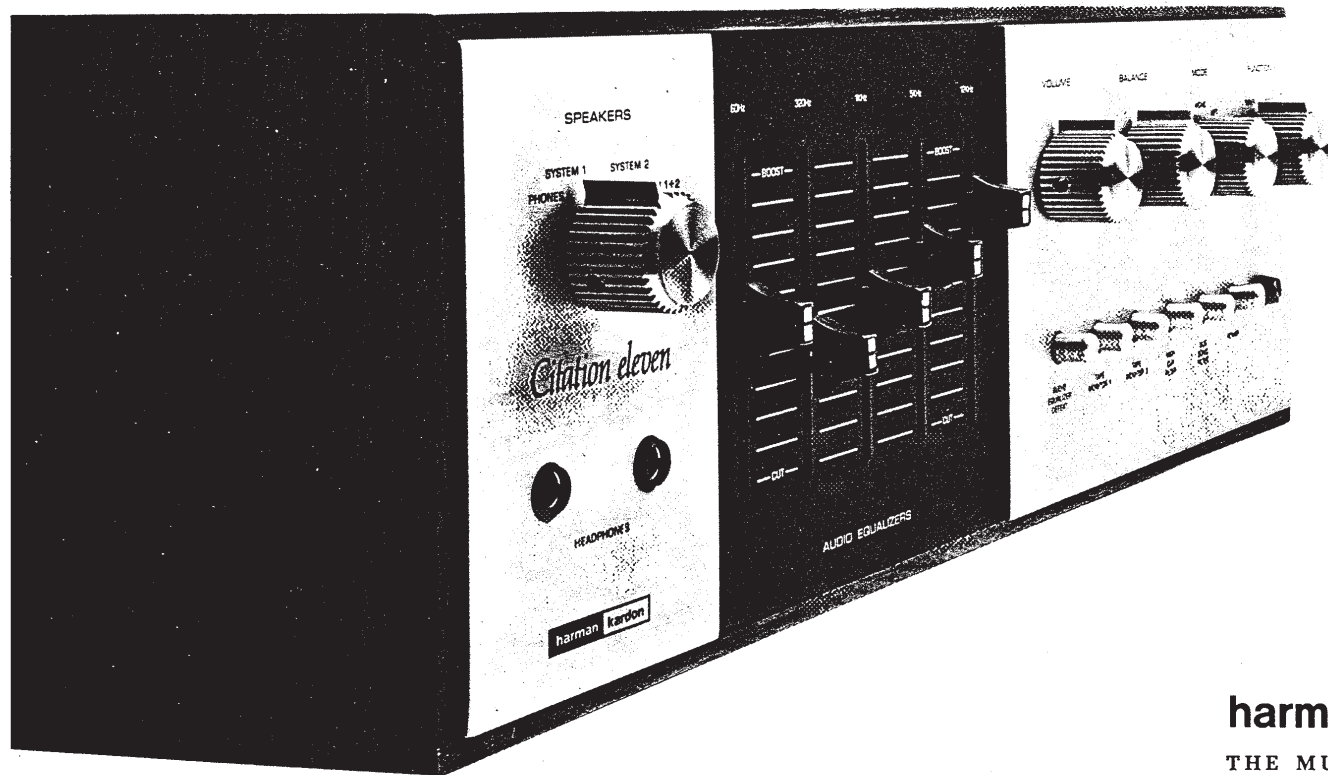

**harman/kardon**  
THE MUSIC COMPANY

“... FOR THE SAKE OF MUSIC AND OUR DEMANDING LOVE OF IT.”

## TABLE OF CONTENTS

	PAGE		PAGE
Introduction .....	2	Simplified Operating Procedure .....	8
Outstanding Features .....	2	Control Description .....	9
Warranty Policy .....	3	Power Switch .....	9
Unpacking .....	3	Function Switch .....	9
Service .....	3	Mode Switch .....	9
Installation .....	4	Volume Control .....	9
Input Connections .....	4	Balance Control .....	9
Phono 1 and Phono 2 .....	4	Speaker Switch .....	11
Ground .....	4	Headphone Receptacles .....	11
Tuner .....	4	High Cut Switch .....	11
Auxiliary .....	4	Tape Monitor Switches 1 and 2 .....	11
Tape Monitor 1 and 2 .....	4	Subsonic Filter Switch .....	11
Output Connections .....	5	Audio Equalizers .....	12
Preamp Output 1 and 2 .....	5	Audio Equalizer Defeat Switch .....	12
Tape Output 1 and 2 .....	5	Making Duplicate Tape Copies .....	13
Power Amplifier Input .....	6	Making Improved Tape Copies .....	14
Speakers .....	6	RIAA Equalization .....	15
Speaker Phasing .....	6	Fuse .....	15
Power Connections .....	7	Maintenance .....	15
AC Convenience Receptacles .....	7	Performance Specifications .....	16
Line Cord .....	7		

## LIST OF ILLUSTRATIONS

	PAGE
Rear Panel Connections .....	5
Amplifier and Speaker Connections .....	6
Power Connections .....	7
Simplified Operating Procedure .....	8
Front Panel .....	10
Graph, High Cut Filter .....	11
Graph, Subsonic Filter .....	11
Graph, Audio Equalizer .....	12
Making Duplicate Tape Copies .....	13
Making Improved Tape Copies .....	14

## INTRODUCTION

With the introduction of the Citation Eleven, Harman-Kardon has once again innovated a major change in the design and function of high-performance solid state stereo preamplifiers. The Citation Eleven uses the potential of transistors more completely and creatively than any other preamplifier in existence. It is a computer-crafted instrument that easily meets or exceeds every performance parameter ever established for a preamplifier. The simple truth is that the Citation Eleven is the best stereo preamplifier ever made.

Ideally, a preamplifier should behave as though it were a straight wire with gain. Any change of the input signal other than its amplitude must be regarded as a form of distortion. Therefore, ideally, our preamplifier should have unlimited bandwidth, no trace of harmonic or intermodulation distortion, no phase shift, no transient distortion, no hum and noise and tremendous dynamic range.

In truth, audio technology has not advanced to the point where a straight wire with gain is a viable reality. If you will study the performance specifications of your new Citation Eleven, we think you will be amazed as to how close we have come toward achieving perfection.

As you listen to your new Harman-Kardon Citation Eleven you get the feeling that you're listening through the electronics clear back to the original performance. The finer nuances of tonal shading stand out clearly and distinctly, making listening to recorded program material a truly emotional experience. Instruments take on the same balance and perspective they exhibit at a live performance. You can actually feel the concert hall and the depth and breadth of the orchestra.

Your new Citation Eleven is representative of Citation Sound . . . which essentially is no sound at all. The more you listen to this new stereo preamplifier, the more aware you become of the music and of the performance, and the less aware of the electronics. This impressive performance is achieved because all forms of distortion are at the residual of laboratory test equipment. There is nothing within the electronics to mask or color the sound. We now ask you to join with us to share the experience of hearing music as you have never heard it before.

## OUTSTANDING FEATURES

- Professional audio equalizers replace standard tone controls. Hinge points located at five critical sections of the audio spectrum give user total control over room acoustics, program material and speaker sound. Settings are instantly repeatable.
- Special defeat switch removes audio equalization controls from circuit for absolutely linear response. Provides instant comparison of equalized and flat response.
- Audio equalizers may be used while taping by connecting second audio output from preamplifier to input of tape recorder.
- Pushbutton on/off switch enables user to turn system on and off without upsetting careful setting of operating controls.
- Two sets of tape recorder outputs permit user to connect two tape recorders to the preamplifier at the same time without necessitating use of "Y" connectors or similar external devices. Both pair of tape recorder outputs provide a signal unmodified by the volume control.
- Two tape monitor switches on front panel permit individual monitoring of two tape recorders.
- Front panel speaker selector permits use of two separate stereo speaker systems in different sections of the home. Listener may select speaker system one, system two or both speaker systems simultaneously.
- Specially designed frequency filter provides sharp cut off of highs without introducing ringing.
- Subsonic noise filter (15 hertz) removes annoying rumble and other low frequency disturbances without drastically affecting the character of the sound.
- Plug-in printed circuit modules provide easy accessibility and professional appearance.
- Six position function selector switch with two low level positions permits use of two individual record players with low level magnetic pickups and four high level sources.
- Special connections on rear panel for connecting power amplifier and speakers to permit use of special speaker switching and headphone receptacles.
- Two year service warranty on parts and labor for factory wired preamplifier.

## WARRANTY POLICY

Please fill in your Citation warranty card completely and mail it to HARMAN-KARDON without delay to protect your rights under warranty. Your HARMAN-KARDON Citation Eleven warranty is not valid unless we have your warranty card on file.

We warrant each factory wired control center to be free from defects in material and workmanship under normal use and service, and in accordance with the conditions set forth below. Should a defect occur within the period specified, and providing the unit is returned to either HARMAN-KARDON or an authorized HARMAN-KARDON warranty station, transportation prepaid, and which our examination shall disclose to our satisfaction to be defective we will for a period of two (2) years from date of original purchase either replace or repair and install any defective parts free of charge.

To obtain service under the terms of this policy, it is necessary for you to retain your ORIGINAL BILL of SALE. The enclosed registration card will NOT be considered proof of purchase.

In the event your equipment requires service during the warranty period, only presentation of your original bill of sale to either a factory-authorized repair agency or the factory, itself, will insure your rights under the policy, as outlined in this manual.

The Citation warranty does not include packaging or transportation charges to and from the factory or authorized warranty repair station.

This warranty is not applicable to any unit which shall have been repaired or altered in any way so as, in our judgment, to affect its reliability or stability or general performance or has been subject to neglect, misuse, abuse, negligence or accident; or which has had the serial number altered, effaced or removed. Neither shall this warranty apply to any instrument which has been connected other than in accordance with instructions furnished by us.

This warranty is in lieu of all other warranties, expressed or implied, and of all other obligations or liabilities on our part, and we neither assume nor authorize any representative or other person to assume for us any other liability in connection with the sale of this instrument.

## UNPACKING

After unpacking the Citation Eleven, inspect it carefully for signs of transit damage. The preamplifier was subjected to numerous quality control tests and inspections prior to packing and should therefore be in perfect operating condition. If damage is visible, notify your dealer at once. If the preamplifier was shipped to you, notify the transportation company without delay. HARMAN-KARDON will cooperate with you in such instances, but only YOU can recover from the carrier for damage incurred during shipment.

## SERVICE

HARMAN-KARDON has a special customer service division to answer all questions pertinent to the installation and operation of your unit. Please feel free to write us at any time and we shall endeavor to offer prompt and complete advice.

If your problem cannot be resolved through our combined efforts, we may wish to refer you to a local authorized repair agency or we may prefer to authorize the return of your unit to the factory. To aid us in selecting a service station convenient to you, it would be helpful if you would indicate which major city is closest to your home.

Please address your inquiry to:

Customer Service Department  
HARMAN-KARDON, INC.  
Plainview, New York 11803

Be sure to include the model and serial number of your unit.

In the event it must be returned, an authorization form and proper packing instructions will be forwarded to you. This authorization form, together with the warranty registration number, **MUST BE RETURNED** with your unit.

**UNDER NO CIRCUMSTANCES SHOULD YOUR UNIT BE SHIPPED TO THE FACTORY WITHOUT PRIOR AUTHORIZATION.**

## PREPARATION FOR USE

### INSTALLATION

The Citation Eleven may be placed at any convenient location within your room. This unit produces absolutely no heat and therefore special ventilation requirements are not necessary. However, in custom installations, it is not recommended to place the Citation Eleven directly over heat producing units such as a basic amplifier or tube type tuner.

The Citation Eleven may be installed in your custom cabinet by following the simple instructions on the mounting template supplied. Alternatively, a handsome furniture finished hardwood enclosure is available from your dealer as an optional extra.

### INPUT CONNECTIONS

#### PHONO 1 and PHONO 2

There are two sets of low level phono receptacles on the rear panel of the Citation Eleven. They are designed for use with any magnetic pickup with a nominal impedance of 42,000 to 52,000 ohms.

This special Citation convenience permits you to connect a record changer and a manual turntable simultaneously, and to switch between them with the function selector located on the front panel. Since both low level inputs are identical and each has been compensated for the RIAA recording curve of today's modern recordings, either or both may be used.

#### GROUND CONNECTION

Under certain conditions it may be necessary to provide a common "ground" between the Citation Eleven and your other associated equipment. This may be accomplished by using either or both of the special GND terminals located on the rear panel of the Citation Eleven.

#### TUNER

Connect a pair of shielded cables (patch cords) from the output of your stereo tuner to the L and R TUNER input receptacles on the rear of the Citation Eleven. With the function switch in the TUNER position, you will be able to hear all FM Stereo, FM or AM broadcasts from your tuner.

### AUXILIARY INPUTS

The Citation Eleven has three pair of AUX input receptacles for use with high level program sources; ceramic or crystal pickup, reel-to-reel tape recorder, cassette tape recorder, TV or a second stereo tuner.

The sensitivity of one of the three sets of receptacles is different from the other two to permit you to connect a high level program source delivering inordinately high output. In this way you are able to maintain a relatively constant volume control level as you switch from function to function.

For example, there are a few tuners or tape recorders currently available which deliver in excess of 1 volt output. If this type of unit was connected to the normal high level input (150 mv) and you were to switch between phono and aux, the relative volume from your speakers would be quite different and you would have to adjust the volume control each time you switched functions. This constant adjustment can be eliminated by using the lower sensitivity (300 mv) input receptacles.

AUX 1—Normal sensitivity (150 mv). For use with standard electronic equipment which has normal output levels of less than 1 volt.

AUX 2—Same as AUX 1

AUX 3—Lower sensitivity (300 mv). For use with electronic equipment which has normal output levels of more than 1 volt.

NOTE: When the function switch is in the AUX 2 position, the TAPE OUT 1 and TAPE OUT 2 receptacles are disconnected and it is **NOT** possible to make any tape recordings. You may however use this position for playback of pre-recorded tapes.

#### TAPE MONITOR 1 and TAPE MONITOR 2

There are two pair of tape monitor receptacles on the rear of the Citation Eleven. Either one or both pair of receptacles may be used to monitor your tapes as you make a recording, provided your tape recorder or recorders have separate record and playback heads. Connect the LEFT and RIGHT line output cables of your tape recorder to the TAPE MONITOR 1 or 2 input receptacles. If one or both pair of TAPE MONITOR receptacles are not used it is recommended that either the (two) or (four) TAPE MONITOR receptacles be terminated with the RCA shorting plugs provided with your unit. Complete operation is explained in detail in the paragraph TAPE MONITOR SWITCH.

## OUTPUT CONNECTIONS

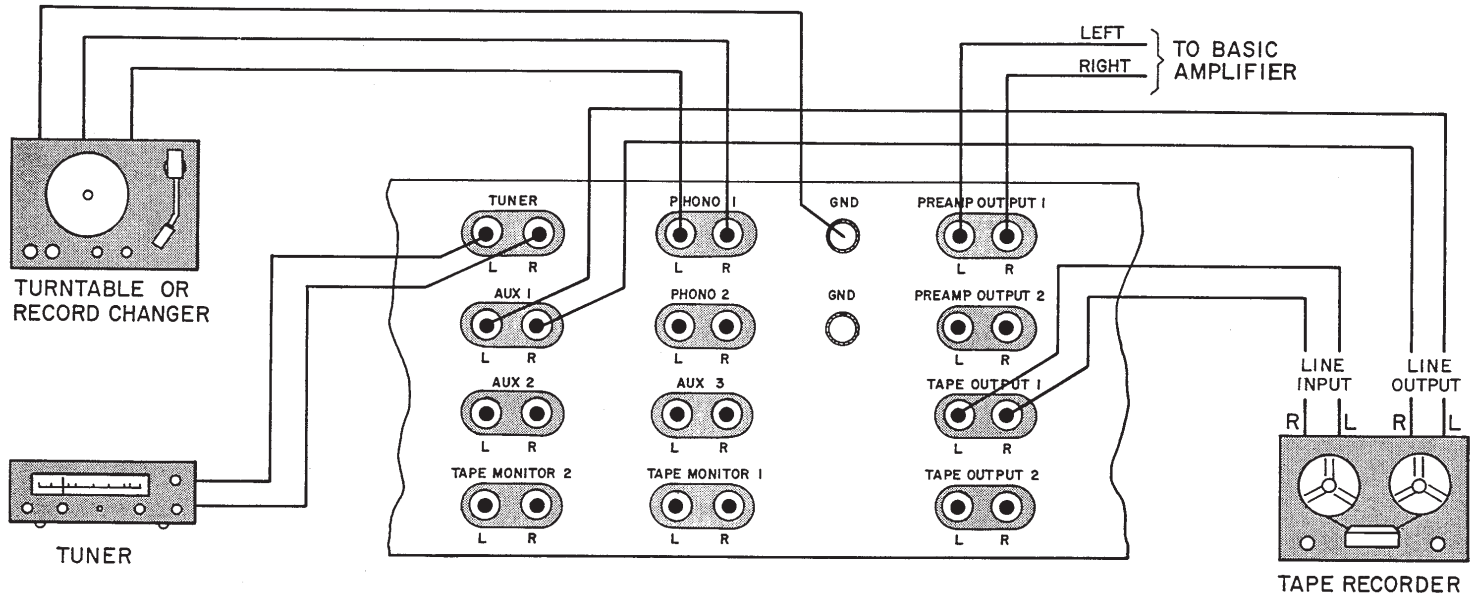

### PREAMP OUTPUT 1 and PREAMP OUTPUT 2

The Citation Eleven was specifically designed for operation with the Citation Twelve Basic Power Amplifier. However, it is eminently suited to driving any other stereo power amplifier, or a pair of monophonic power amplifiers. If two monophonic amplifiers are used, it is strongly suggested that they be a matched pair.

Two pairs of preamplifier output receptacles are provided. These can be used to drive two entirely separate stereo power amplifiers in different locations. Shielded leads with standard RCA phono plugs are used for making the connections. These can be obtained from your dealer in the lengths required. Because the Citation Eleven uses a low

impedance output, the power amplifier may be located at any distance up to 50 feet from the Citation Eleven.

### TAPE OUTPUT 1 and TAPE OUTPUT 2

Provision is made to permit the recording of any program material connected to the Citation Eleven with the exception of the AUX 2 receptacles. The signals appearing at either of the TAPE OUTPUT receptacles are identical and are unaffected by any of the front panel controls except the function and mode switches. Connect two shielded cables from the LEFT and RIGHT line input of your tape recorder to either the L and R TAPE OUTPUT 1 or L and R TAPE OUTPUT 2 receptacles on the rear of your Citation Eleven.

## POWER AMPLIFIER INPUT

In conventional separate preamplifier/amplifier combinations all speakers must be connected to the basic power amplifier and any provision for switching one or more speaker systems must be accomplished either at the basic amplifier or with an external speaker switch.

The Citation Eleven is extremely versatile in that with the proper connections all speaker switching can be controlled from the front panel of the Citation Eleven.

A special connecting cable has been supplied to connect the speaker output of your basic amplifier to a special connector on the Citation Eleven where it can be controlled by the Speaker Selector Switch. The connections to the basic amplifier should be made as follows:

Green Wire .....	Left Channel hot (+)
Black Wire .....	Left Channel Gnd (-)
Red Wire .....	Right Channel hot (+)
White Wire .....	Right Channel Gnd (-)

Then plug the male connector of this cable into the POWER AMPLIFIER INPUT receptacle on the rear of the Citation Eleven.

## SPEAKERS

You may connect either two speakers (one system) or four speakers (two systems) to the rear of the Citation Eleven. Be sure to observe polarity (+ and -) as shown on the speaker connection drawing.

## SPEAKER PHASING

When more than one speaker is used in a music reproducing system, the speakers must be connected in a manner which will allow them to work together. Both left and right speakers must operate in perfect unison, moving back and forth together. If the speakers are moving in opposite directions, the result will be diminished bass response and decreased realism of sound. When this occurs, the speakers are said to be out of phase. Checking for proper phase and correcting, if required, is quite simple.

- 1) Place the MODE switch in the MONO position.
- 2) Play a record, tape, or FM broadcast which has a single speaking or singing voice, or a solo instrument.
- 3) The voice or instrument should appear to be coming from an area directly between the two speakers. If the speakers are out of phase, the sound will appear to be coming from the two individual speakers.
- 4) If you determine that the speakers are out of phase, simply disconnect the leads from only one of the speakers and reverse them. The system will then be in phase.

## SPEAKER CONNECTIONS

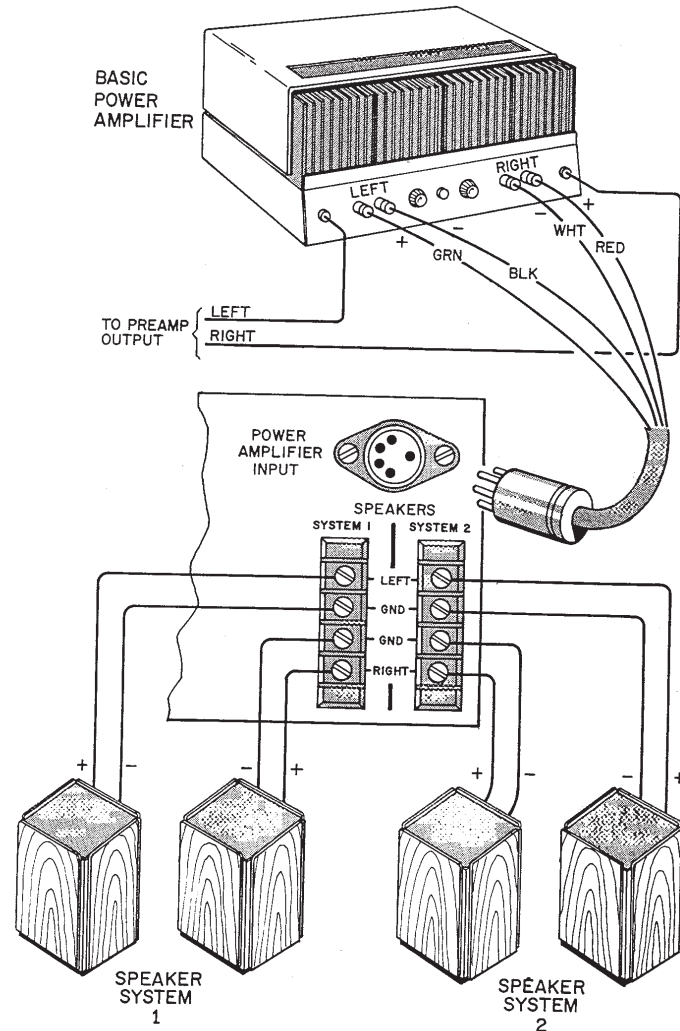

## POWER CONNECTIONS

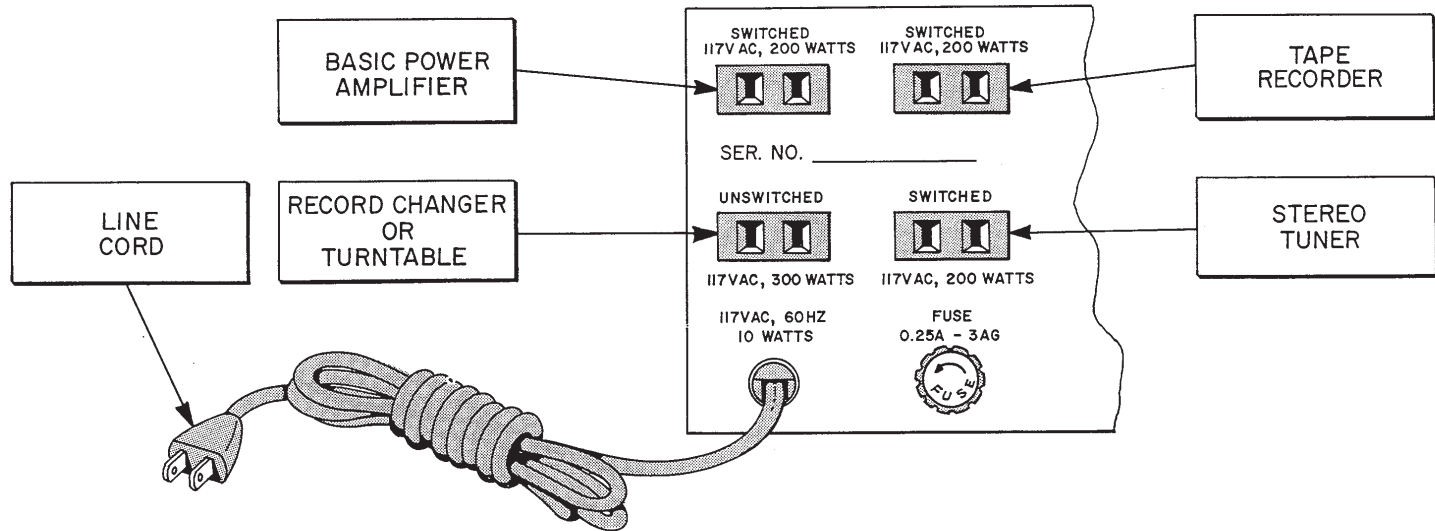

### LINE CORD

With the POWER switch in the OFF position, plug the line cord into any outlet furnishing 105-125 volts, 50 or 60 Hz current.

For use in areas which require 220 volt, 50 Hz current, the Citation Eleven may be rewired by following the procedure outlined in the Technical Manual. However, this should only be performed by a qualified technician.

### AC CONVENIENCE RECEPTACLES

Four AC convenience receptacles are provided on the rear panel of

the Citation Eleven, one being live at all times and three being live only when the power switch is ON. These receptacles may be used to power your associated equipment and if connected to the SWITCHED receptacles, this equipment will be controlled by the ON/OFF POWER switch.

A record changer or turntable should be connected to the UNSWITCHED receptacle as these devices are best controlled by their own switches in order to avoid the possibility of developing flats on the idler wheels.

## SIMPLIFIED OPERATING PROCEDURE

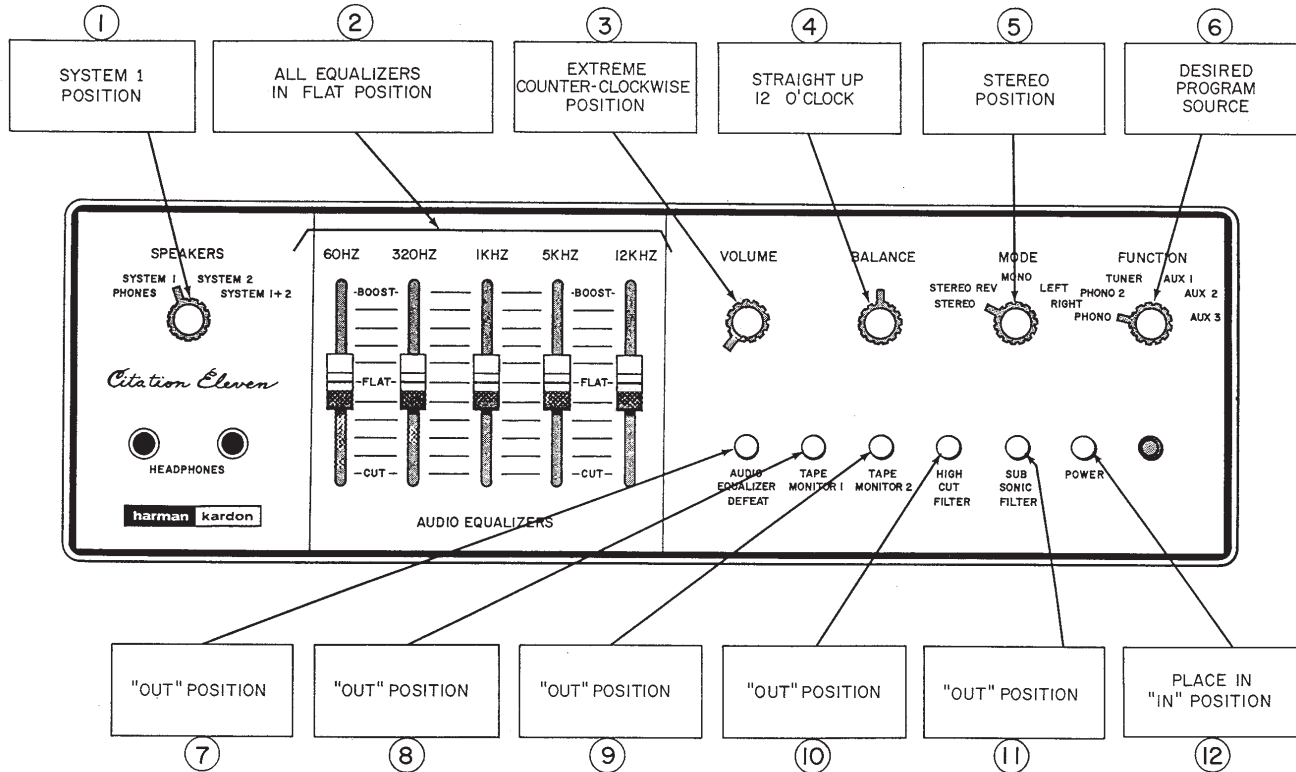

If you are operating the Citation Eleven for the first time, follow the simple step by step instructions numbered 1-12 as shown on the SIMPLIFIED OPERATING PROCEDURE DRAWING.

Approximately 15-20 seconds after the power has been turned on,

rotate the volume control clockwise until the desired listening level is obtained. After you have operated the unit and you wish to take full advantage of all the versatile controls of the Citation Eleven, study the sections of this manual entitled CONTROL DESCRIPTION.

## CONTROL DESCRIPTION

Each control on the Citation Eleven has been designed to perform a specific useful function. In order to utilize the capability of these controls we suggest you read the following descriptions so you may have a better understanding of their use.

### POWER SWITCH

The POWER switch performs the function as its name denotes. It supplies power to the preamplifier and to the switched AC convenience outlets. When the switch is ON, the pilot light jewel will be illuminated.

The Citation Eleven also incorporates a special time delay circuit which reduces the level of the signal at the PREAMP OUTPUT receptacles by approximately 20 dB when the unit is first turned on. After 15 or 20 seconds the signal will gradually increase to its normal output level. This special time delay is provided to prevent possible damage to your speakers, which could be caused by transient signals being amplified while the internal circuits of your preamplifier are reaching their steady state operating conditions.

### FUNCTION SWITCH

The FUNCTION switch has six positions and is used to select the desired type of program source.

- 1) PHONO 1 (with RIAA equalization)
- 2) PHONO 2 (with RIAA equalization)
- 3) TUNER
- 4) AUX 1
- 5) AUX 2
- 6) AUX 3

You may also record any program material selected in these positions with the exception of AUX 2.

## MODE SWITCH

The MODE switch selects between stereophonic and monophonic operation depending upon the program source. The switch has five positions as follows:

- 1) STEREO . . . . . Normal stereo operation
- 2) STEREO REV . . . . . To reverse left and right channels for your listening preference
- 3) MONO . . . . . Combined left plus right channels
- 4) LEFT . . . . . Left channel signal to L and R outputs
- 5) RIGHT . . . . . Right channel signal to L and R outputs

## VOLUME CONTROL

The VOLUME control adjusts the signal level of any program material connected to your stereo system. It is a two section control which simultaneously adjusts both channels, and its close tracking specifications insure that the relative volume level of each channel will be identical.

## BALANCE CONTROL

The nature of stereo reproduction is such that it requires two identical channels to attain the highest degree of faithfulness and spatial distribution. Any variation in the efficiency of one channel as compared to the other will disturb this relationship. Since there may be slight differences between the two speakers, the tape heads, etc., the Citation Eleven includes a control to balance one channel against the other. Sufficient range is covered by this control to permit rebalancing of the overall system even in cases where major unbalance exists. This control may be set anywhere within its range to attain system balance. It does not necessarily have to be set in the exact vertical position.

When the BALANCE control is properly set, the apparent sound source will lie in a broad area between the two speakers. When the BALANCE control is rotated to the right the sound will move to the right and when the control is rotated to the left, the sound will move to the left.

## FRONT PANEL

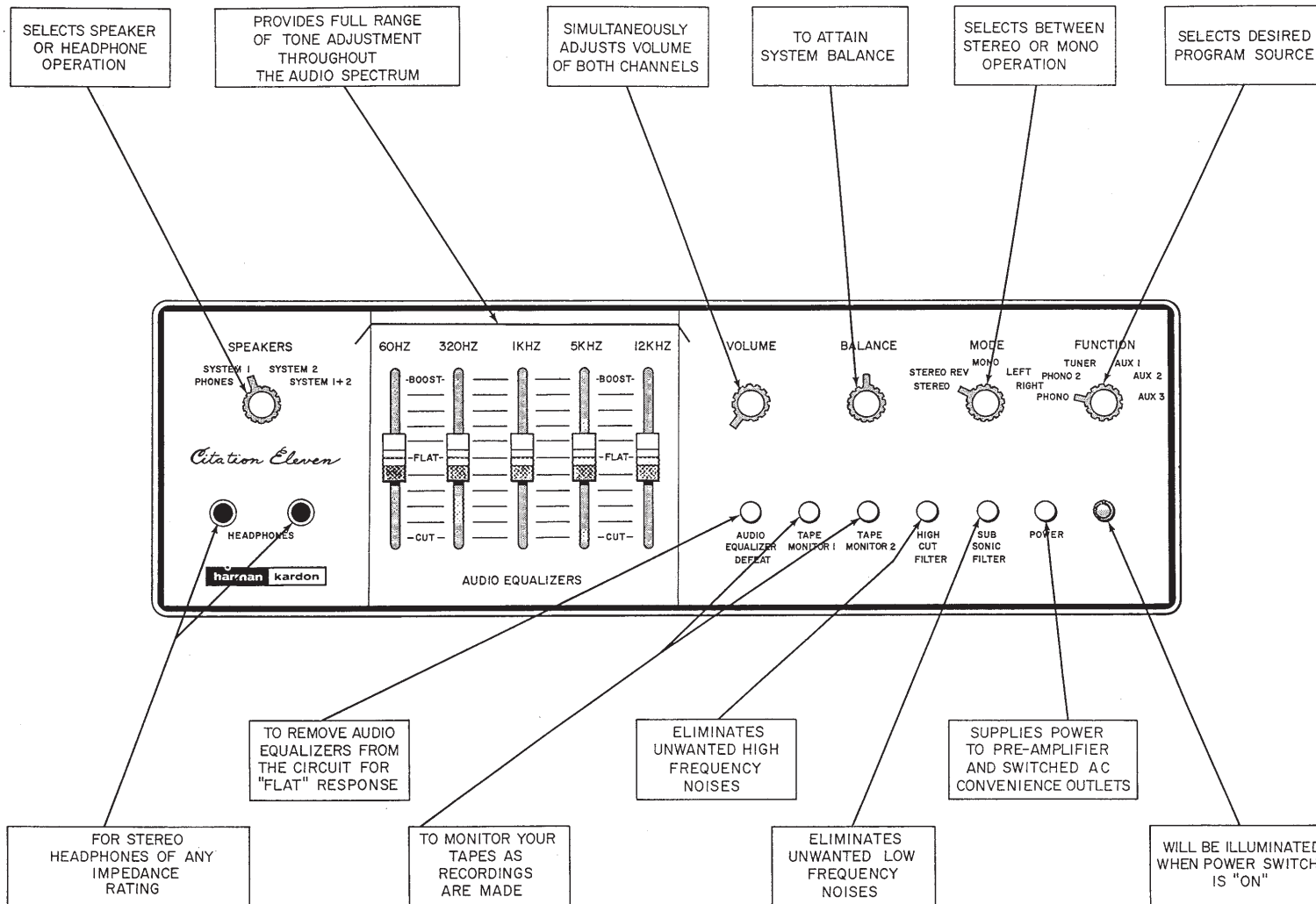

## SPEAKER SWITCH

The SPEAKER switch permits the selection of stereo speakers in one or two rooms independently or simultaneously. You may also use this switch to listen to your stereo headphones while your speakers are disconnected from the system.

## HEADPHONE RECEPTACLES

The Citation Eleven provides two headphone receptacles which will accommodate any type standard stereo headphones regardless of impedance. In order to listen to the headphones, the SPEAKER switch must be in the PHONES position.

## HIGH CUT FILTER SWITCH

The HIGH CUT FILTER has been designed to reduce the high frequency response of the Citation Eleven. This will reduce annoying record scratch, tape hiss, FM background noise, etc. When IN, this circuit provides an 8 dB reduction @ 10k Hz with a 6 dB per octave slope.

HIGH CUT FILTER CHARACTERISTICS

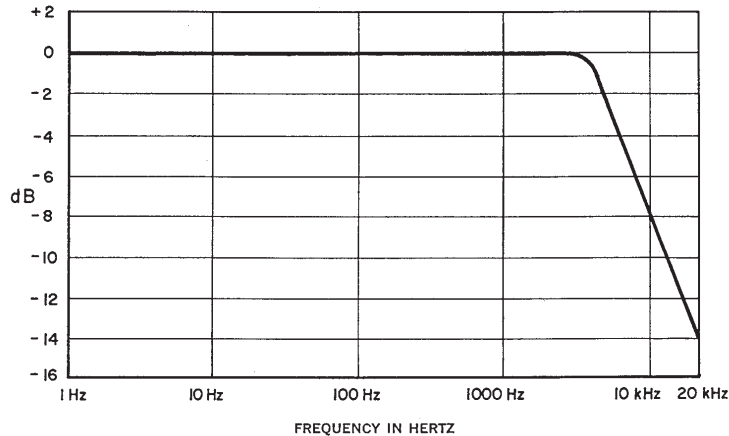

## TAPE MONITOR SWITCHES 1 and 2

As explained previously the Citation Eleven has provided two pairs of TAPE OUT receptacles to permit recording of program material being reproduced by your stereo system.

If your tape recorder is of the professional type and has a third head for "monitoring", it is possible to compare the recording with the original while it is being made. Simply push the appropriate TAPE MONITOR switch (depending on which TAPE MON receptacles you are using) to the IN position to listen to the recording after it has been made and back to the OUT position to listen to the program material you are recording.

If you have two professional recorders, each with a monitoring feature, you may monitor each one individually. However, if both TAPE MONITOR switches are IN, TAPE MONITOR 2 will take preference to prevent mixing of both channels.

## SUBSONIC FILTER SWITCH

The SUBSONIC FILTER has been designed to remove annoying turntable rumble and other low frequency disturbances without drastically affecting the character of the sound. When IN, this switch provides a 12 dB reduction at 15 Hz with a 6 dB per octave slope.

SUBSONIC FILTER CHARACTERISTICS

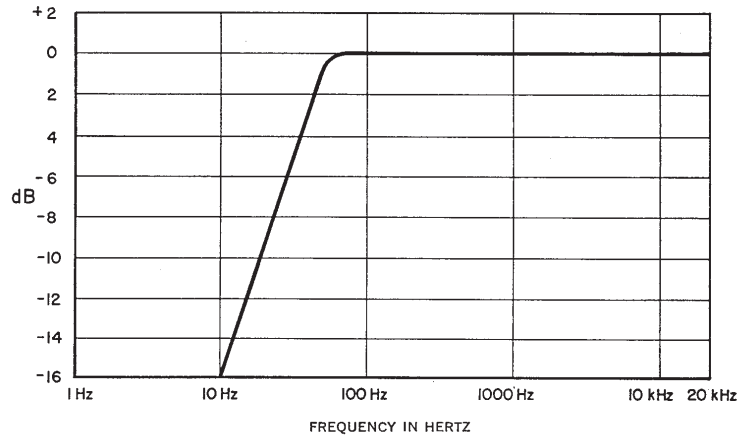

## AUDIO EQUALIZERS

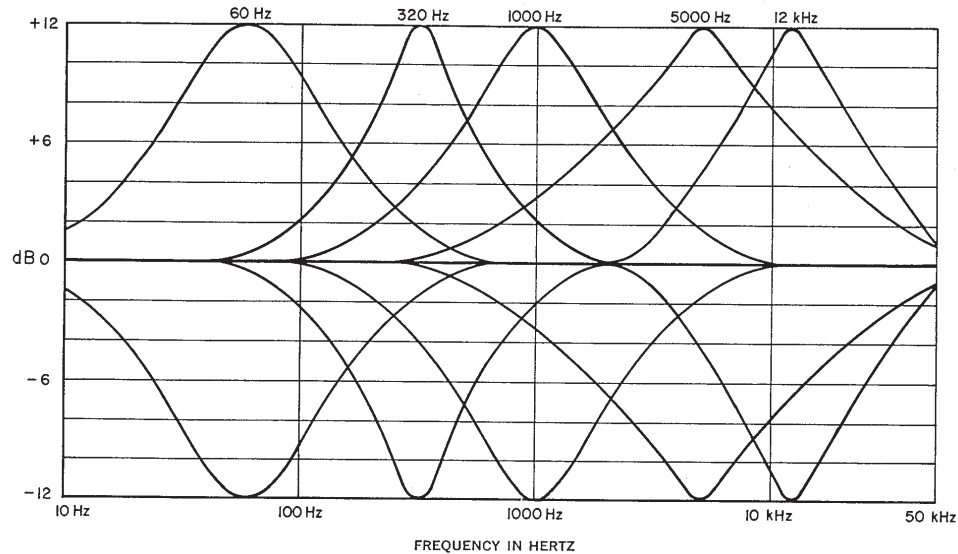

### AUDIO EQUALIZERS

This is one of the most important new design concepts incorporated into your Citation Eleven. Harman-Kardon engineers have determined that standard tone controls, even professional switched types, limit flexibility for they do not permit precise adjustment of program material over the entire audio range. The Citation Eleven employs a professional type audio equalizer which gives the user complete control over program material, room acoustics and deficiencies within the speakers.

Operating at five predetermined hinge points (60 Hz, 320 Hz, 1k Hz, 5k Hz and 12k Hz) the audio equalizer adds or deletes audio energy to any point within the audio spectrum to compensate for inaccuracies in program material or within the playback system. It is no longer required to match room acoustics to the speakers by repositioning furniture or by adding draperies or rugs to the room. The Citation audio equalizer controls room acoustics by permitting the

user to set the five controls to suit his own personal acoustic conditions. Hot spots, ear-piercing highs, frequency response drop out, excessive bass and even mid-frequency harshness can now be cancelled out by adding or deleting audio energy at the specific points in the audio spectrum where these problems occur.

The normal operating position of the five audio equalizers would be in the center or "flat" position. Each equalizer provides a range of adjustment of  $\pm 12$  dB at the hinge frequency and can be adjusted to your own personal listening preference.

### AUDIO EQUALIZER DEFEAT SWITCH

This switch permits you to remove the audio equalizer controls from the circuit to provide an absolutely linear response. You may use this switch for instant comparison of program material with either an equalized or flat response.

## MAKING DUPLICATE TAPE COPIES

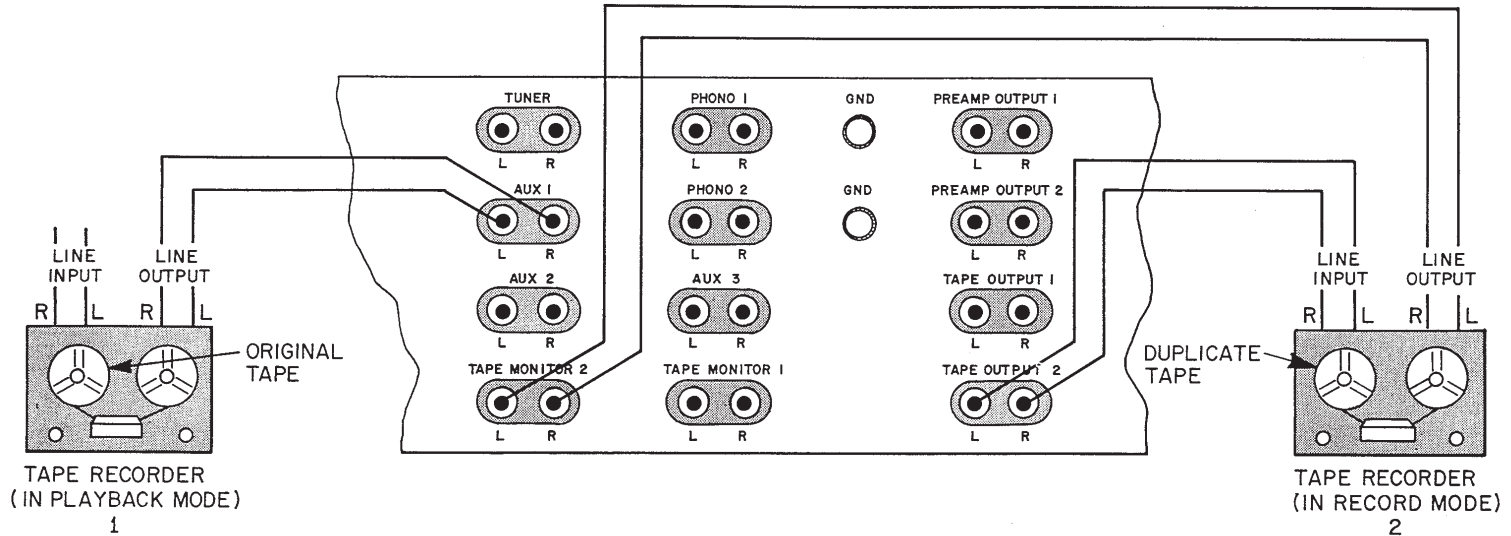

The Citation Eleven may be used to make exact duplicate copies of your reel-to-reel or cassette tapes. This may be accomplished by the following:

- 1) Connect the LINE OUTPUTS of tape recorder 1 (set for playback) to the AUX 1 inputs.
- 2) Connect the LINE INPUTS of tape recorder 2 (set for record) to either TAPE OUTPUT 1 or 2 (whichever is not being used).
- 3) Connect the LINE OUTPUTS of tape recorder 2 to TAPE MONITOR 1 or 2 (whichever is not being used.)
- 4) Set the FUNCTION switch to the AUX 1 position.
- 5) Set both tape recorders in operation and you will now be duplicating your tape from tape recorder 1 to tape recorder 2.
- 6) If you wish to monitor the tape as it is being made you may now use the appropriate TAPE MONITOR switch, 1 or 2, to compare the before and after recording quality.

## MAKING IMPROVED TAPE COPIES

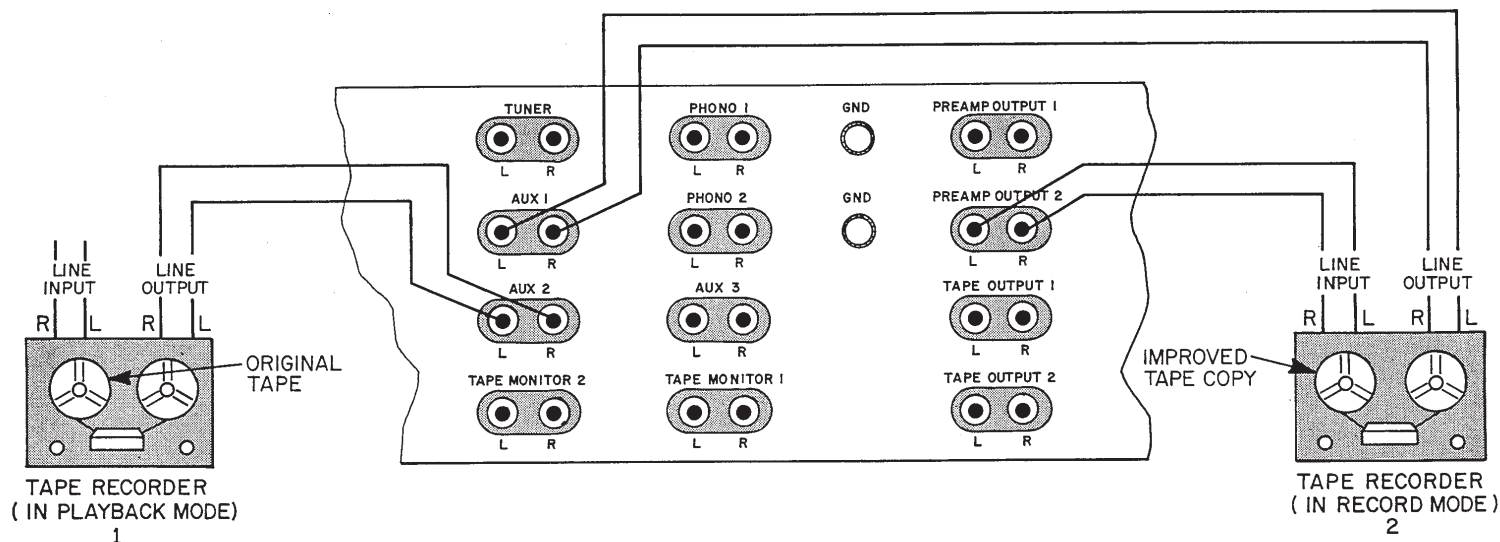

Another versatile feature of the Citation Eleven permits you to copy one tape to another and make any improvements you desire in volume, balance, noise level or tone quality. This may be accomplished by the following:

- 1) Connect the LINE OUTPUTS of tape recorder 1 (set for playback) to the AUX 2 inputs.
- 2) Connect the LINE INPUTS of tape recorder 2 (set for record) to either PREAMP OUTPUT 1 or 2 (whichever is not being used).
- 3) Connect the LINE OUTPUTS of tape recorder 2 to the AUX 1 inputs.
- 4) Set the FUNCTION switch to the AUX 2 position.
- 5) Play tape recorder 1 (in playback) and tape recorder 2 (in record) and adjust any of the front panel controls to your per-

sonal preference for improvements in volume, balance, noise level or tone quality.

- 6) As the input signal to tape recorder 2 is now affected by all your adjustments, you are now making an improved version of your original tape.
- 7) After your improved tape is made disconnect the line inputs of tape recorder 2.
- 8) Rewind both tapes (the original and the improved copy) to their respective starting positions.
- 9) Place both tape recorders 1 and 2 in the playback mode.
- 10) Using your FUNCTION selector switch you may now compare the original tape to the improved copy by switching between AUX 1 and AUX 2.

## RIAA EQUALIZATION

In order to assure good reproduction of the wide range of frequencies in music and to make necessary adjustments for the limitations of the recording technique, record manufacturers have found it necessary to modify the actual frequency response of the music while it is being recorded. Thus, to avoid overcutting and consequent distortion, a measured and deliberate reduction is effected in low frequency response by selecting a "turnover frequency" and by recording attenuated response below that point. To assure optimum signal to noise ratio at the high frequency and when the record is played at home, the highs are deliberately exaggerated during the recording process. A measured and deliberate boost is effected above a certain frequency. This combination of deliberate exaggeration at the low and high ends of the frequency range can be expressed in a "recording curve". When the record is played a mirror image of that curve should be available so that the ideal "flat" response may be achieved. This recording curve has been incorporated in both the PHONO 1 and PHONO 2 positions of the function switch.

## FUSE

In the event of a potentially damaging failure of components, the Citation Eleven is protected by a ¼ amp-3AG fuse located on the rear panel. If this fuse blows, replace only with one of the same rating. Replacing with a fuse of a higher rating **WILL NOT** protect the preamplifier, and may result in severe damage, which will not be covered by the factory warranty.

## MAINTENANCE

The front panel escutcheon and the control knobs are gold anodized for a durable finish and lasting beauty. The audio equalizer knobs are a molded plastic material. They may all be cleaned with a very mild detergent and water solution applied with a soft cloth or cotton swab. **NEVER** use a strong abrasive cleaner or scouring powder as this could damage the finish of these parts.

All the variable controls (5 audio equalizers, volume and balance) have been manufactured with a special silicone lubricant for smooth and easy operation. These controls should **NEVER** be cleaned with any commercial cleaner or solvent.

## PERFORMANCE SPECIFICATIONS

### AUDIO OUTPUT

into 10,000 ohms ..... up to 6 volts RMS

### FREQUENCY RESPONSE

5-125K hertz .....  $\pm 0.5$  dB  
 2-250K hertz .....  $\pm 1.0$  dB

### HARMONIC DISTORTION

6 volts RMS, 10-30,000 hertz ..... less than 0.05%  
 2 volts RMS ..... less than residual of  
 test equipment

### IM DISTORTION

equivalent 6 volt RMS ..... less than 0.05%

### SQUARE WAVE RISE TIME

at 20,000 hertz ..... less than 1 microsecond

### SQUARE WAVE TILT

at 20 hertz ..... less than 5%

### SENSITIVITY (for 2 volts output)

low level, Phono 1 and Phono 2 ..... 1.5 millivolts  
 high level, Aux 1 and Aux 2 ..... 150 millivolts  
 high level, Aux 3 ..... 300 millivolts

### NOISE (UNWEIGHTED)

low level @ 10 mv reference ..... 65 dB below 6 volts  
 high level, volume at maximum ..... 80 dB below 6 volts  
 residual, volume at minimum ..... 90 dB below 6 volts

### HIGH CUT FILTER

@ 10,000 hertz ..... -8 dB

### SUBSONIC FILTER

@ 15 hertz ..... -12 dB

### INPUT IMPEDANCE

phono ..... 47,000 ohms  
 aux ..... 20,000 ohms

### OUTPUT IMPEDANCE

source ..... less than 500 ohms  
 recommended load ..... 10,000 ohms or more

PHONO OVERLOAD ..... greater than 115 mv

PHONO EQUALIZATION ..... RIAA curve  $\pm 0.5$  dB

### AUDIO EQUALIZERS

at each hinge point .....  $\pm 12$  dB