

# OPERATING INSTRUCTIONS & SERVICE MANUAL

SOLID-STATE STEREO AMPLIFIER

## SANSUI AU-777A

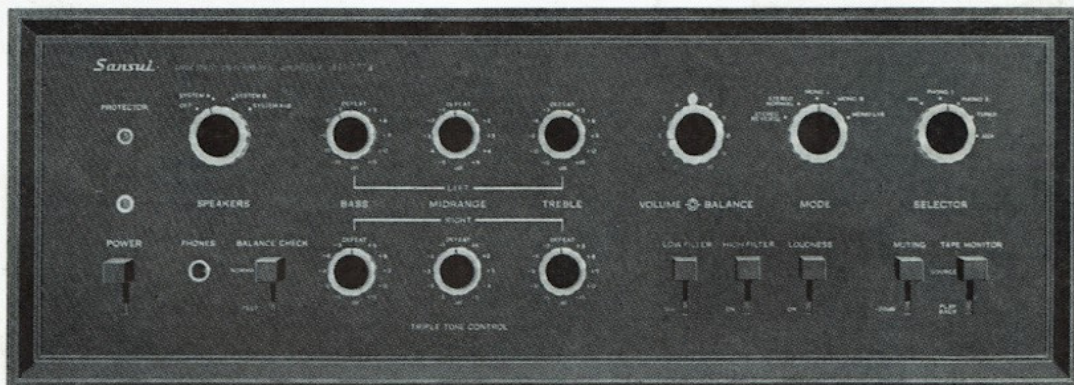

sansui

SANSUI ELECTRIC COMPANY LIMITED

Thank you for selecting the Sansui AU-777A Solid State Stereophonic Amplifier, an excellent choice that will become more apparent after years of rich stereo listening.

Sansui is known throughout the world for the unsurpassed quality of its audio equipment line, be it a pre-main amplifier, a multiplex stereo receiver, a speaker system, a turntable or a stereo headphone set, and takes the greatest efforts to merit and maintain this reputation.

The AU-777A is no exception. Not a single detail has been overlooked in bringing this unit to you in perfect operating condition.

This manual has been prepared to aid you in keeping the AU-777A working perfectly. *Please read the contents of this manual carefully before installing or operating the amplifier.*

You will then be able to enjoy the world's highest standards of sound reproduction to the fullest.

## CONTENTS

---

SWITCHES AND CONTROLS .....	3, 4, 5, 6
OPERATIONS .....	7, 8
—SPEAKER CONNECTION	
—RECORD PLAYING	
—MICROPHONE	
OPERATIONS.....	9, 10
—RADIO RECEPTION	
—TAPE PLAYBACK	
—TAPE RECORDING	
ELECTRONIC CROSSOVER SYSTEM .....	11, 12
THREE-CHANNEL STEREO.....	13
MAINTENANCE .....	14, 15, 16
SPECIFICATIONS.....	17
CHARACTERISTICS .....	18
TROUBLESHOOTING CHART.....	19, 20
CUSTOM MOUNTING.....	21, 22
PARTS LAYOUT .....	23
BLOCK AND LEVEL DIAGRAM.....	24
ALIGNMENT	
—TEST POINT.....	25
—MAIN-AMP SECTION OUTPUT, CURRENT ADJUSTMENT.....	26
PRINTED CIRCUIT SHEETS AND PARTS LIST .....	27, 28, 29, 30, 31, 32
OTHER PARTS CHART AND LIST .....	33, 34



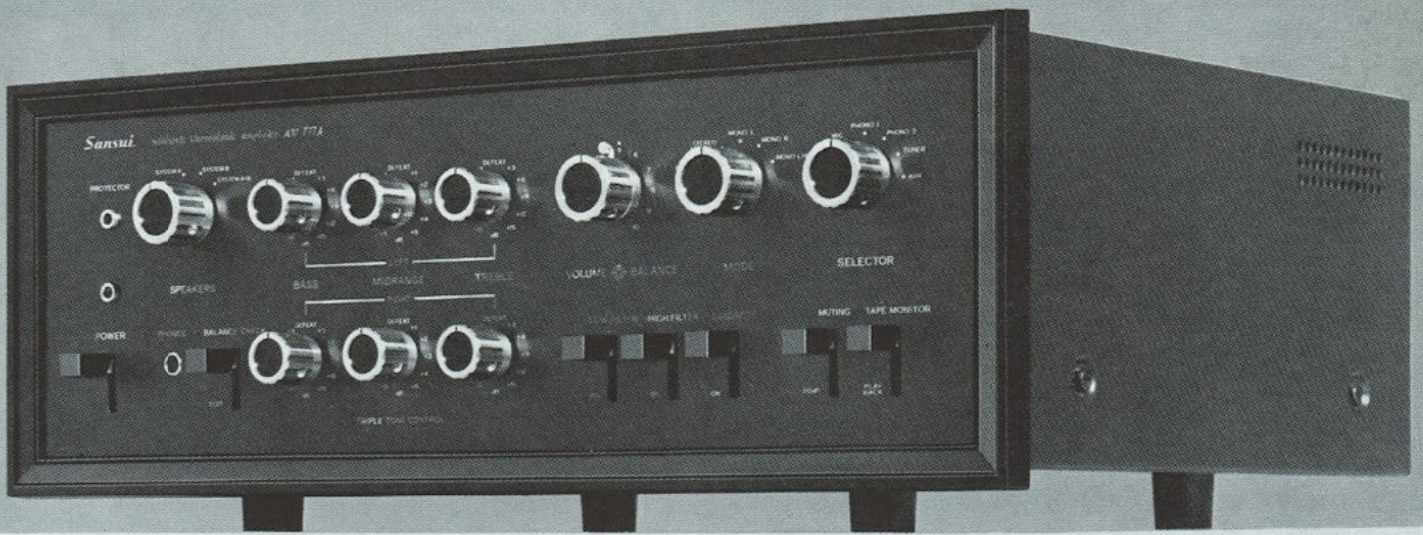



# SWITCHES AND CONTROLS

## Balance Control

This control adjusts for equal sound from both left and right channels to compensate for slight imperfections in program material, variations in speaker output, and the vagaries of room acoustics.

## Speakers Switch

This switch is used to choose between one set of speakers A and another set B, which may be installed in the same room or remotely in another part of your home. It also has a position for running all speakers at once (A+B), and another that cuts them all out for private listening with headphones (OFF).

## Protector Indicator

The protector circuit prevents damage to power transistors. As soon as the circuit is activated, the indicator lamp lights up to indicate trouble. In this case, immediately turn the POWER switch off and remedy.

## Power Indicator

The POWER indicator is lit when the POWER switch is turned ON. It remains lit while the unit is on.

## Power Switch

The amplifier is on when the POWER switch lever is moved to the ON position. On the rear panel of the amplifier there are two A.C. outlets. The power to the left outlet marked SWITCHED is controlled by the POWER switch.

## Headphones Jack

Plug in a headset for private listening or monitoring. The PHONES jack will accept any standard stereo phono plug but a dynamic headset is recommended.

## Balance Check Switch

This switch is used to check whether the sound levels from both right and left speakers are equal. Set the MODE switch to any MONO position; turn the BALANCE CHECK switch to the TEST position; and adjust the BALANCE control so that the sound levels from both speakers are minimized. When not in use, make sure the switch is in the NORMAL position.





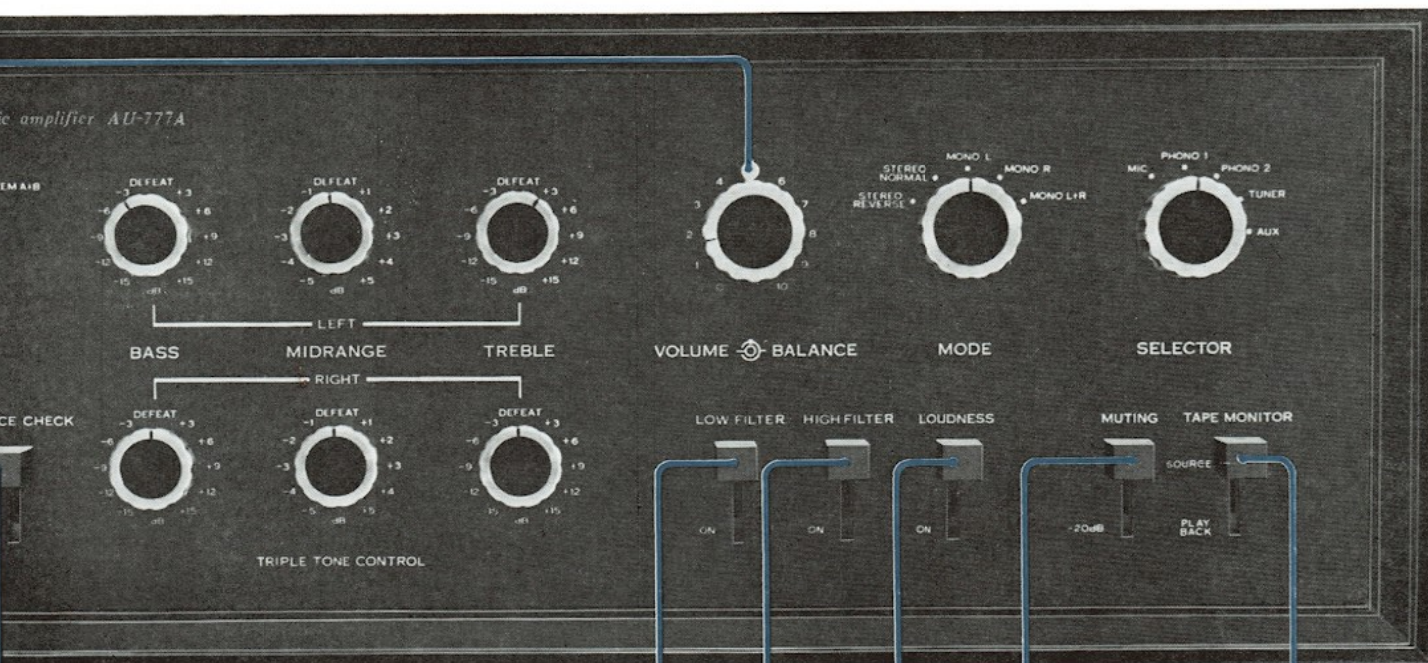

### Low Filter

Turntable rumble and other low-frequency noises are reduced by setting the LOW FILTER switch to the ON position.

### High Filter

Surface noise from old or worn records, tape hiss and other high-frequency noises are reduced by setting the HIGH FILTER switch to the ON position.

### Loudness Control

Whenever the volume is decreased to a low listening level, the music will seem to lose much of its bass and some of its treble. This effect is due to the sensitivity of human hearing. When the LOUDNESS switch is on, it provides the correct amount of bass and treble boost required to compensate for this change.

### Muting Switch

The MUTING switch attenuates music by 20 dB over the whole frequency range. It is used to eliminate interstation tuning noise, to suppress the background noise heard when changing a record, and to reduce the over-all sound level temporarily while playing a record and other program sources.

### Tape Monitor Switch

This switch enables you to compare a recorded tape with the original program. When this switch is in the PLAY BACK position, the recorded tape is heard from the speakers. Monitoring is only possible with a 3-head tape recorder. **Note:** When you play back through the amplifier, the TAPE MONITOR switch should be in the PLAY BACK position as well. When not in use, make sure the switch is in the SOURCE position.



# SWITCHES AND CONTROLS

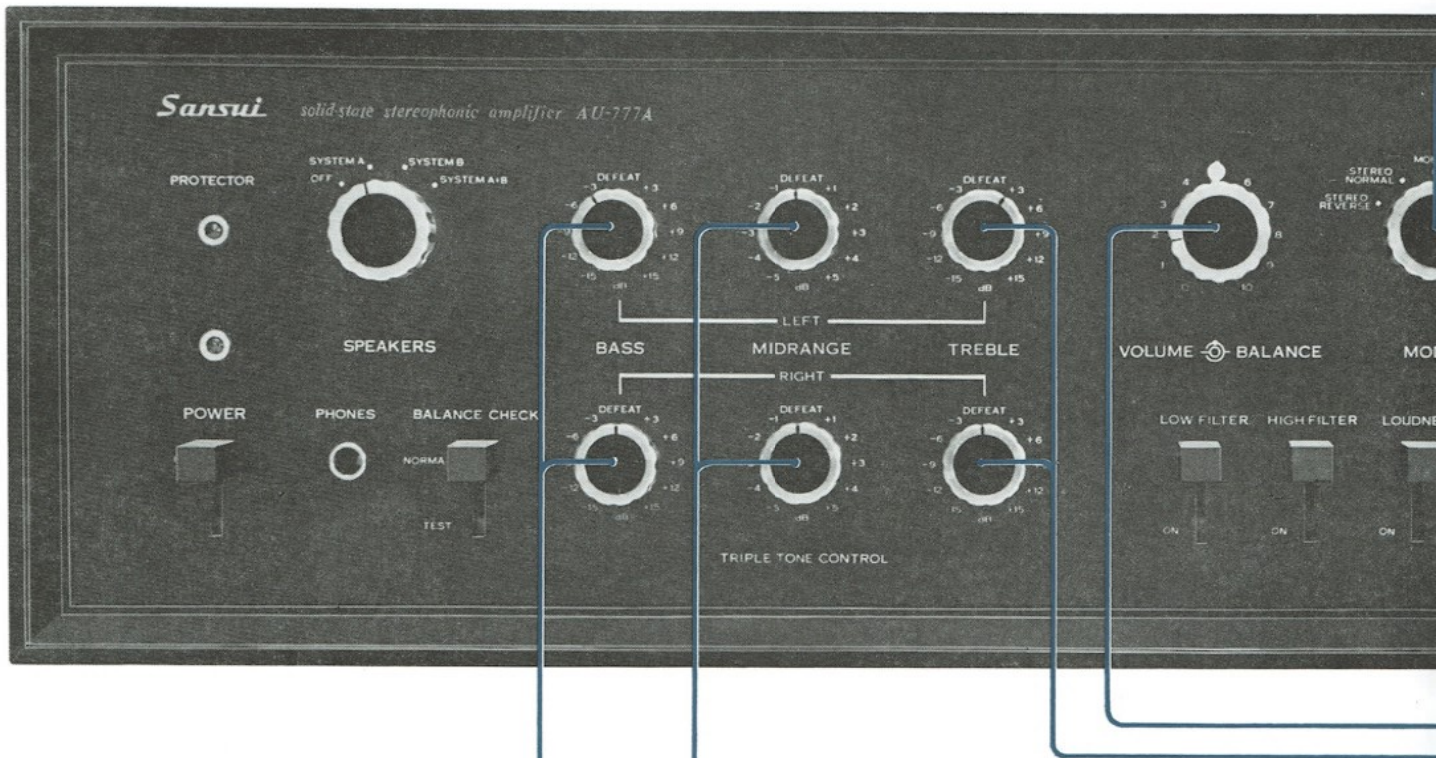

## Bass Controls

The LEFT and RIGHT BASS controls determine the amount of bass tones in the left and right channels respectively. With the BASS controls in mid-position marked DEFEAT, the bass tones will sound exactly as recorded or broadcast. If you wish to emphasize the bass, simply turn the BASS controls clockwise. To decrease the bass loudness, turn the BASS controls counterclockwise. The BASS controls are graduated by 3 dB per step.

## Midrange Controls

The LEFT and RIGHT MIDRANGE controls determine the amount of midrange tones in the left and right channels respectively. With the MIDRANGE controls in mid-position marked DEFEAT, the midrange tones will sound exactly as they appear in the program source. If you wish to emphasize the midrange, simply turn the MIDRANGE controls clockwise. To decrease the midrange loudness, turn the MIDRANGE controls counterclockwise. The MIDRANGE controls are graduated by 1 dB per step.



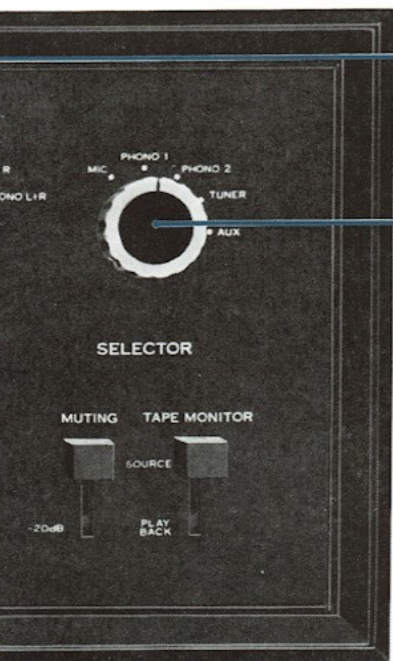

## Mode Switch

1. **STEREO REVERSE**—The MODE switch in the STEREO REVERSE position connects the left input to the right speaker and the right input to the left speaker.
2. **STEREO NORMAL**—The MODE switch in the STEREO NORMAL position connects the left input to the left speaker and the right input to the right speaker. This is the normal stereo position.
3. **MONO L**—The MODE switch in the MONO L position connects the left input to both speakers.
4. **MONO R**—The MODE switch in the MONO R position connects the right input to both speakers.
5. **MONO L+R**—The MODE switch in the MONO L+R position connects the L+R input to both speakers.

## Input Selector Switch

This switch selects from among the various program sources connected to the input jacks on the rear panel of the amplifier.

1. **MIC**—Selects a microphone connected to the MIC inputs.
2. **PHONO 1**—Selects a record player connected to the PHONO 1 inputs on the rear panel.
3. **PHONO 2**—Selects a record player connected to the PHONO 2 inputs.
4. **TUNER**—Selects a tuner, FM-MPX adaptor or other sources connected to the TUNER inputs.
5. **AUX**—Selects a tuner, FM-MPX adaptor or other sources connected to the AUX inputs.

## Volume Control

This control adjusts the over-all sound level of both channels. Turn it clockwise, and the volume is increased; turn it counterclockwise, and the volume is decreased.

## Treble Controls

The LEFT and RIGHT TREBLE controls determine the amount of treble tones in the left and right channels respectively. With the TREBLE controls in mid-position marked DEFEAT, the treble tones will sound exactly as they appear in the program source. If you wish to emphasize the treble, simply turn the TREBLE controls clockwise. To decrease the treble loudness, turn the TREBLE controls counterclockwise. The TREBLE controls are graduated by 3 dB per step.



# OPERATIONS

## — SPEAKER CONNECTION

## — RECORD PLAYING

## — MICROPHONE

### Connecting Loudspeakers

Any speakers of 4- to 16-ohm impedance can be used with this amplifier. If you wish to connect a remote stereo speaker system in addition to the main set of speakers in your listening room, you can connect the set to the SYSTEM-B terminals on the rear panel of the amplifier. The speaker selector switch on the front panel of the amplifier enables you to choose between A and B speaker systems. It also has a position for running all speakers at once, and another that cuts them all out for private listening with headphones.

### One Speaker System

To connect the main set of speakers to the amplifier:

1. Connect the positive terminal of the speaker on your right (as viewed from the listening area) to the right channel SYSTEM-A (+) terminal on the rear of the amplifier.
2. Connect the lead from the negative speaker terminal (marked -) to the right channel SYSTEM-A (-) terminal on the rear of the amplifier.
3. The left speaker connections are made at the left channel SYSTEM-A terminals on the rear of the amplifier in the manner described above.
4. Set the SPEAKERS selector to SYSTEM-A.

In connecting speakers to the amplifier, no more than  $\frac{1}{4}$ -inch of insulation should be removed from the end of a speaker cable, since any greater length of exposed wire is likely to cause shorts at the terminals. All wire strands should be tightly twisted. To connect, depress the terminal button with one hand, push the stripped end of lead wire in the hole with the other hand, and release the button.

### Two Speaker systems

If you wish to connect another set of speakers in the same room or remotely, you can connect such speakers to the SYSTEM-B terminals of each channel as indicated in the preceding section. When the SPEAKERS selector is in the SYSTEM B position, you will hear sound from the speakers con-

nected to the SYSTEM B terminals. With the selector in the (A+B) position, the sound comes from all the speakers connected to the amplifier.

## RECORD PLAYERS

### Connecting Record Players

The AU-777A has two sets of PHONO inputs to accommodate a pair of players or pickup arms. The PHONO 1 input impedance is 50 k $\Omega$ . The PHONO 2 can be switched between 30, 50 and 100 k $\Omega$  by means of the PICK UP LOAD switch on the rear panel.

To connect a record player to the amplifier, proceed as follows:

1. Connect the left channel output of the record player to the LEFT PHONO 1 (or PHONO 2) input jack on the rear of the amplifier.
2. Connect the right channel output of the record player to the RIGHT PHONO 1 (or PHONO 2) input jack.
3. If a monophonic player or turntable is used, it may be connected to either LEFT or RIGHT PHONO input jack.

### Listening to a Stereo or Monophonic Record

1. Set the SELECTOR switch to PHONO 1 or PHONO 2 depending on which input is being used.
2. Set the MODE switch to STEREO. If a monophonic record player is used, set the MODE switch to MONO.
3. Make appropriate settings of controls on the record player.
4. Place the needle on the record.
5. Adjust the BALANCE control for equal sound from both right and left speakers.
6. Use all other controls and switches according to your personal taste and room acoustics.

**Note:** When monophonic records are played on a stereo player, follow the same procedures as for stereophonic records for better results.

Insert the power-cord plug of the player into the A.C. outlet marked SWITCHED on the rear of the



amplifier. The power supply will then be controlled by the POWER switch on the front panel of the amplifier.

## MICROPHONES

One or two microphones can be connected to the MIC inputs on the rear of the amplifier. Use high-impedance 50-k $\Omega$  dynamic or velocity microphones for optimum performance.

## Connections

If two microphones are used, connect one to the RIGHT MIC input and the other to the LEFT MIC input. If

only one microphone is used, connect it to either RIGHT or LEFT MIC input.

## Operation

1. Turn the SELECTOR switch to MIC.
2. If two microphones are used, set the MODE switch to MONO (L+R) for mixing the two input signals. If only one microphone is used, set the MODE switch to MONO L or MONO R depending on which input is being used.
3. Use all other controls and switches according to taste and listening conditions.

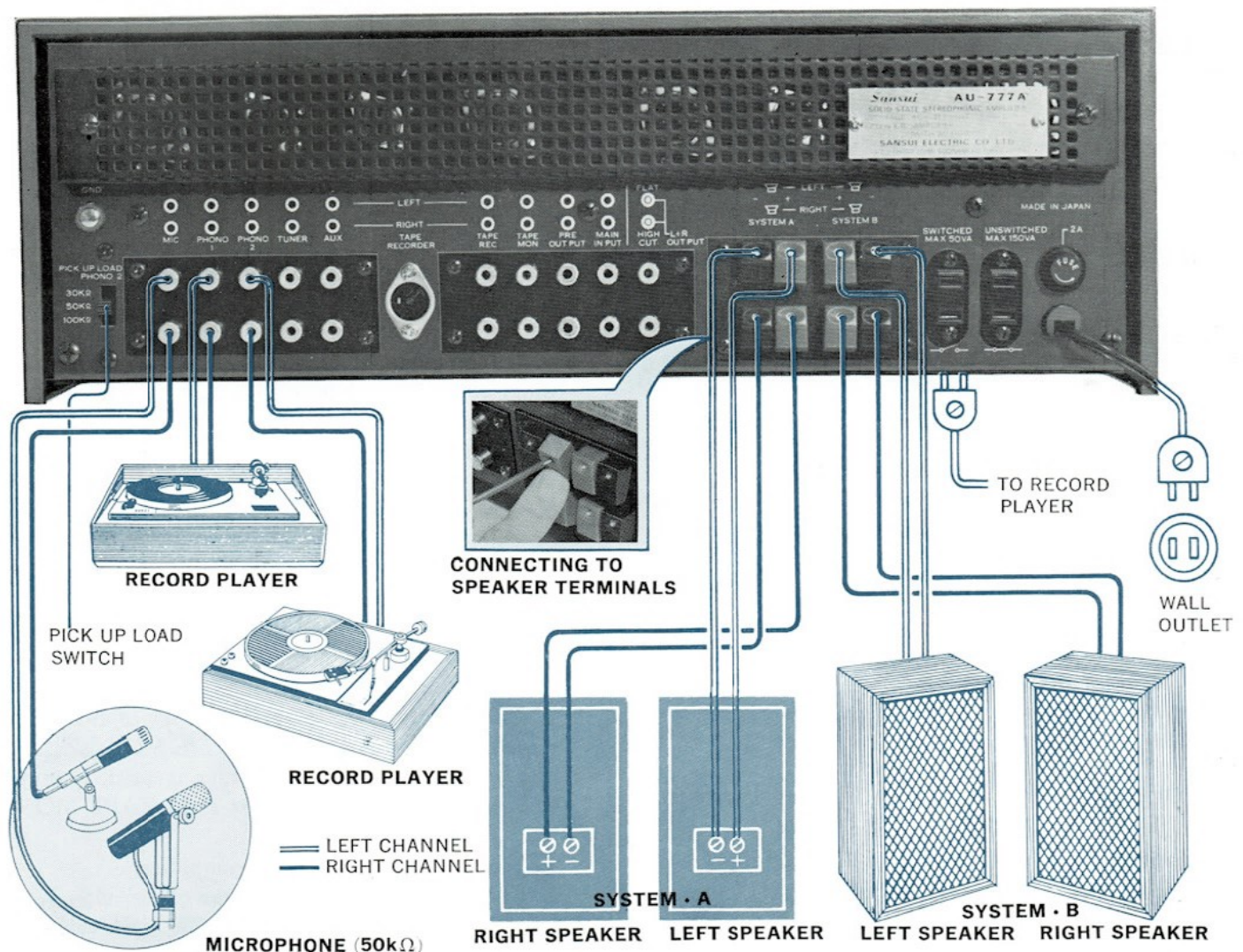



# OPERATIONS

## — RADIO RECEPTION

## — TAPE PLAYBACK

## — TAPE RECORDING

### TUNERS

#### Connecting Tuners

For a stereo tuner, connect its left channel output to the left channel TUNER (or AUX) input jack, and its right channel output to the right channel TUNER (or AUX) input jack. For a monophonic tuner, connect its output to either left or right jack. For use with an FM-MPX adaptor, connect the tuner output to the adaptor input; then connect the left channel output of the adaptor to the left channel TUNER (or AUX) jack, and the right channel output of the adaptor to the right channel TUNER (or AUX) jack.

#### Listening to a Stereo FM Program

1. Set the SELECTOR switch to TUNER or AUX depending on whether a stereo tuner has been connected to the TUNER or the AUX inputs on the rear of the amplifier.
2. Set the MODE switch to STEREO.
3. Use tuning controls to reach the desired station. Make appropriate settings of controls on the tuner.
4. Adjust the amplifier's front panel controls and switches according to your personal taste and room acoustics.

#### Listening to a Monophonic Program

1. Set the SELECTOR switch to TUNER or AUX depending on whether a tuner has been connected to the TUNER or the AUX inputs on the rear of the amplifier.
2. Set the MODE switch to MONO.
3. Use tuning controls to reach the desired station. Make appropriate settings of controls on the tuner.
4. Adjust the amplifier's front panel controls and switches according to your personal taste and room acoustics.

#### For Use with a FM-MPX Adaptor

1. Set the SELECTOR switch to TUNER or AUX depending on whether a FM-MPX adaptor has been connected to the TUNER or the AUX inputs on the rear of the amplifier.

2. Set the MODE switch to STEREO.
3. Use tuning controls to reach the desired station.
4. Make appropriate settings of controls on the FM-MPX adaptor.
5. Adjust the amplifier's front panel controls and switches according to your personal taste and room acoustics.

### TAPE RECORDERS

#### Connecting Tape Recorders

Tape recorders can be connected to record from, and playback through, the AU-777A. Tape monitoring is possible with a tape recorder having a built-in pre-amplifier as well as separate recording and playback heads.

#### DIN Plug Tape Recorder

If your tape recorder has a DIN (German Industrial Standard) 5-pin plug, plug it into the TAPE RECORDER socket on the rear panel of the amplifier.

#### Pin Jack Tape Recorder

To record on tapes from the amplifier:

1. Connect the left channel input of the tape recorder to the left channel TAPE REC jack on the rear of the amplifier.
2. Connect the right channel input of the tape recorder to the right channel TAPE REC jack.
3. If a monophonic tape recorder is used, it may be connected to either LEFT or RIGHT TAPE REC jack.

To playback through the amplifier:

1. Connect the left channel output of the tape recorder to the left channel TAPE MON jack on the rear of the amplifier.
2. Connect the right channel output of the tape recorder to the right channel TAPE MON jack.
3. If a monophonic tape recorder is used, it may be connected to either left or right TAPE MON jack.

To monitor tapes through the amplifier:

1. Connect the left channel input of the tape recorder to the left channel TAPE REC jack and the



right channel input of the tape recorder to the right channel TAPE REC jack.

2. Connect the left channel output of the tape recorder to the left channel TAPE MON jack and the right channel output of the tape recorder to the right channel TAPE MON jack.

### Recording on Tapes

1. Set the SELECTOR switch to the program to be recorded.

2. Set the MODE switch to STEREO. If a monophonic tape recorder is used, set the switch to MONO.

3. Make appropriate settings of controls on the tape recorder.

### Listening to Tapes

1. Turn the TAPE MONITOR switch to PLAY

BACK.

2. Set the MODE switch to STEREO. If a monophonic tape recorder is used, set the switch to MONO.

3. Make appropriate settings of controls on the tape recorder.

4. Use the amplifier's front panel controls and switches according to your personal taste and listening conditions.

### Tape Monitoring

Monitoring is possible only with a tape recorder which has its own playback preamplifier as well as separate recording and playback heads. Set the TAPE MONITOR switch to PLAY BACK and use all other controls and switches according to your personal taste and listening conditions.

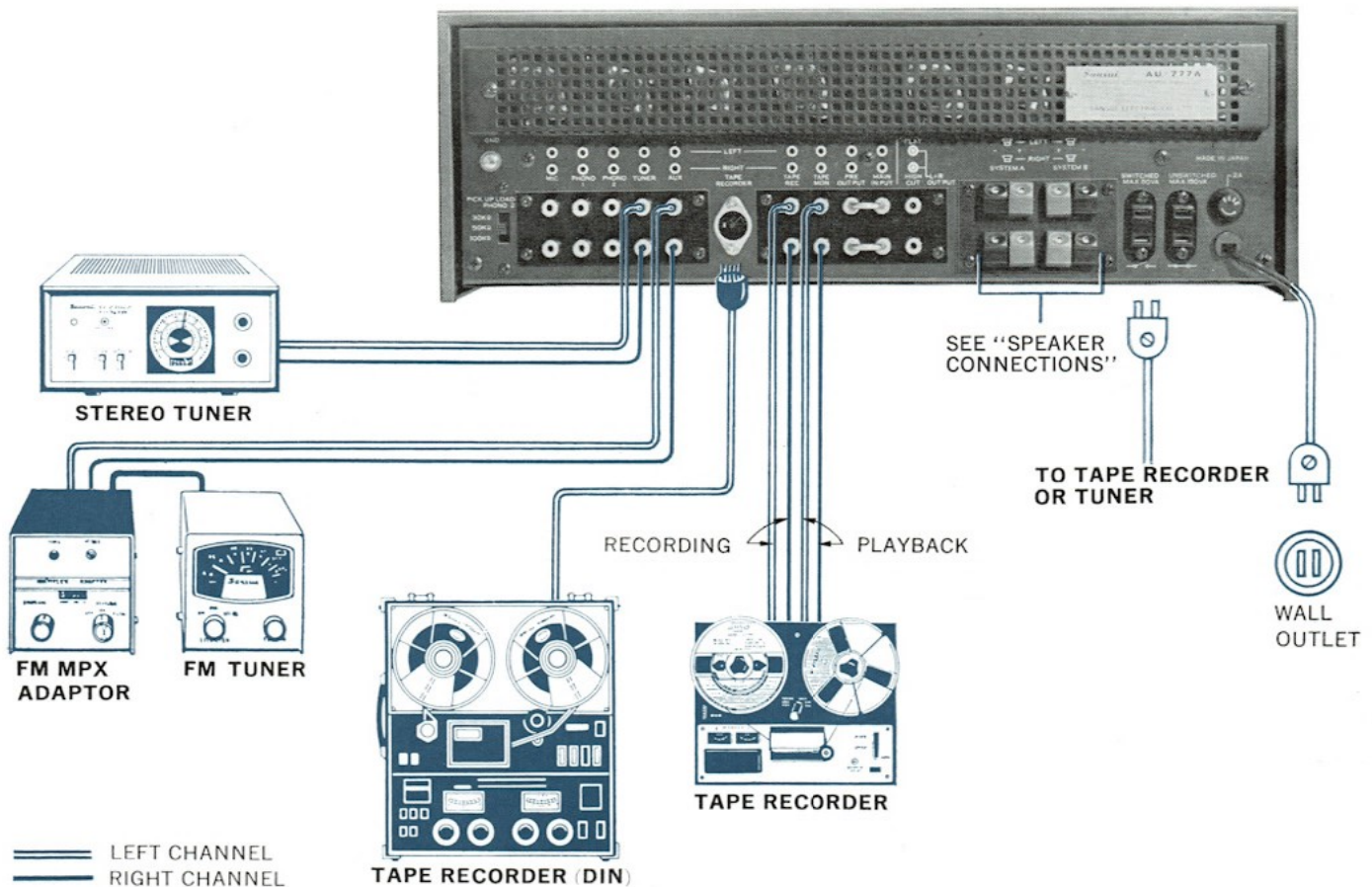



# ELECTRONIC CROSSOVER SYSTEM

## Separate Pre-amp and Main-amp Circuits

The AU-777A is provided with a pre-amp output circuit which picks up the output of the pre-amplifier alone, and with a main-amp input circuit which drives the main amplifier alone.

To connect additional pre- and main-amplifiers:

1. Remove the PM connectors from the jacks marked PRE OUTPUT and MAIN INPUT on the rear of the amplifier.
2. The input of an additional main amplifier should be connected to the PRE OUTPUT jacks. The output of an additional pre-amplifier should be connected to the MAIN INPUT jacks.

**Note:** The connection of the additional pre-amplifier to the MAIN INPUT jacks cuts off all front panel switches and controls except the BALANCE CHECK and SPEAKERS switches. Thus, to adjust the tone and volume, operate the controls of the additional pre-amplifier connected to the AU-777A. When the additional main amplifier is connected to the PRE OUTPUT jacks, the tone and volume can be adjusted by the controls of the AU-777A.

## Electronic Crossover System

The AU-777A's separate pre-amp and main-amp circuits enable you to arrange an electronic crossover system. In this system, each frequency band is divided on the input side, rather than the output side of the amplifier; woofers, midranges and tweeters have their own amplifier as illustrated.

The electronic crossover system is said to be the best hi-fi sound reproduction method available, featuring the following advantages:

1. Since the tweeters, midranges and woofers have their own amplifier, any speakers of different impedance and efficiency can be used for stereo arrangement.
2. This system has better filter characteristics than the conventional LC crossover network. You can determine the optimum crossover points for the speakers used.

3. Since there is no component between the amplifier and speaker, the damping factor of the amplifier is not affected and it is directly coupled to the speaker.

4. This system allows use of the power amplifiers effectively and efficiently. For instance, a big-power amplifier can be used for woofers, and ones with good characteristics for midranges and tweeters. You can select the amplifiers suitable for each of the woofers, midranges and tweeters.



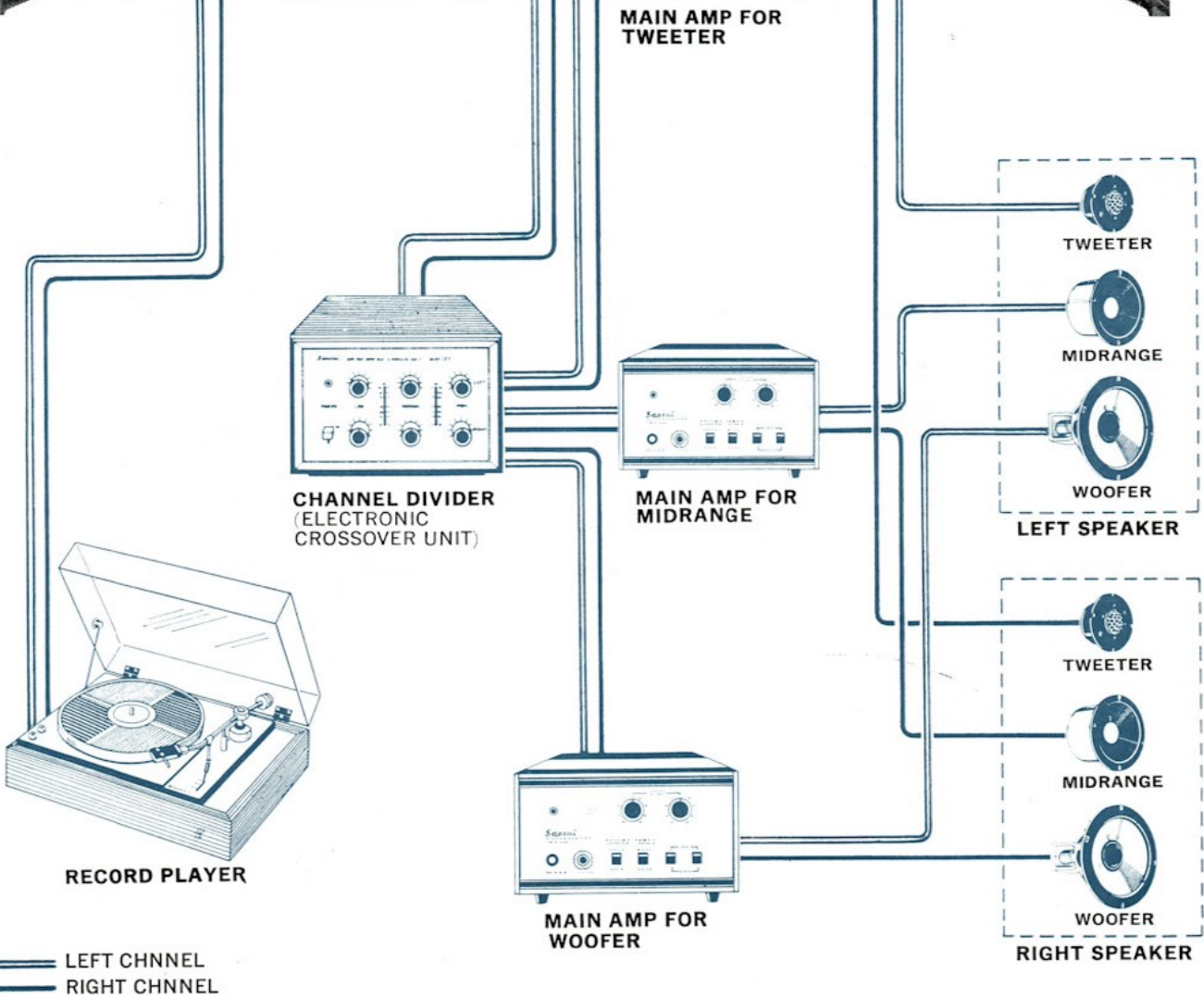



# THREE-CHANNEL STEREO

## Three-Channel Stereo

In the three-channel stereo arrangement, one woofer is connected to the center channel and a tweeter/midrange speaker system is connected to the right and left channels. This concept is based on the fact human ears are not sensitive to the direction of bass tones of less than 200~300 Hz. The advantage is that only one woofer is enough for this stereo arrangement and that lows are reproduced more effectively.

The AU-777A is provided with output terminals for a center-channel amplifier. If you wish to connect a center-channel speaker for the three-channel stereo arrangement, connect an additional amplifier to the HIGH CUT terminal (the frequencies of more than 159 Hz are cut off in the filter circuit of the AU-777A); and then connect the third speaker to the center-channel amplifier. Another method

is to connect a monophonic power amplifier to the FLAT terminal and the third speaker to the amplifier. In this case, mixed sound from the right and left channels does not pass through the filter circuit.

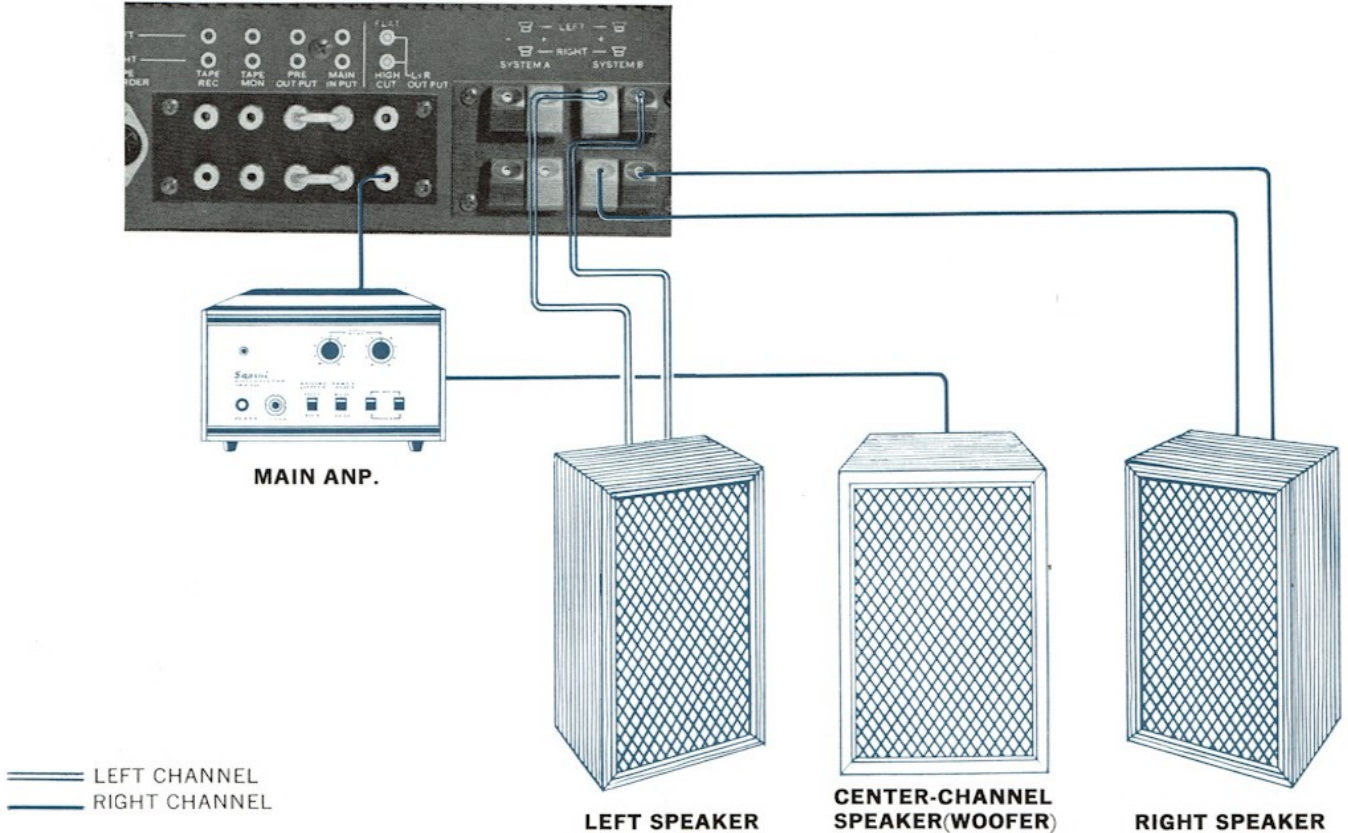



# MAINTENANCE

## PM Connectors

**Warning:** Be sure to push the POWER switch OFF before removing the PM connectors.

The PM connectors hook up the PRE OUTPUT and MAIN INPUT terminals on the rear panel of the amplifier so that the pre and main amplifiers can be used individually and separately. When the PM connectors are removed, the pre and main amplifier circuits are opened. They should not be removed except when connecting additional pre-and/or main amplifiers. Refer to the section titled Separate Pre-amp and Main-amp Circuits.

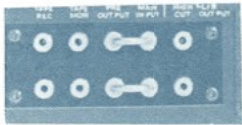

## Balance Check

Headphones cannot be controlled by the BALANCE CHECK switch. Before using the headphones, balance unequal sound levels from the speakers by using the BALANCE CHECK switch as described in the section titled SWITCHES AND CONTROLS, and then use the headphones.



## Phasing of Speakers

Stand about 10 feet in front of and midway between the speakers and listen to any monophonic reproduction. If the speakers are correctly phased, the sound will seem to come from between the speakers. If the sound is not directly in front of you, the speakers are incorrectly phased. To correct this, switch the amplifier off and reverse the leads to one speaker.

Care should be taken not to connect a single speaker system between the SYSTEM A and B terminals.

## Hum and Howling

If, when using a tape recorder or record player, unpleasant humming or howling is heard, it is usually a result of the following.

The record player is placed on or near the speaker box causing sound waves to be transmitted from the speaker to the player (howling). To prevent this, place the record player away from the speaker box or put a thick cushion between the two components.

A low buzzing sound will also be produced if adequately thick shieldwire is not used for connections, or if connections have not been properly made. Be sure that the shieldwire is properly soldered to the pin-plugs as illustrated in "Connecting Wire", and that the motor and pickup arm or the record player are properly grounded.

## Speaker Impedance

Combined impedance of speakers in each channel should not be less than 4 ohms. Too low impedance may activate the PROTECTOR circuit or may cause damage to the amplifier after use over a long period.

## Tape Recorder

1. Tape recorded sound cannot be controlled by the controls and switches on the front panel of the amplifier. They control sound from the speakers only.
2. For better results, record directly through the AU-777A, rather than through microphones placed in front of the speakers.
3. Before connecting and operating the tape recorder, be sure to look up the manufacturer's operating instructions.
4. The TAPE MONITOR switch should be in the SOURCE position except when the tapes are being monitored or played back by the tape recorder. When the switch is in the PLAY BACK position, signals from any other source will not be heard from the speakers.

# MAINTENANCE

## Power Fuse

If the unit remains completely dead when the power is switched on (POWER indicator fails to light), the power fuse is probably blown. In this case, remove the power plug from its AC outlet and replace the fuse after finding and eliminating the trouble that caused the fuse to blow. (Consult the Troubleshooting Section in your Service Manual)

*Use only a glass-tubed 2-ampere fuse.* Never attempt to use a piece of wire or a fuse of a different capacity as a substitute.

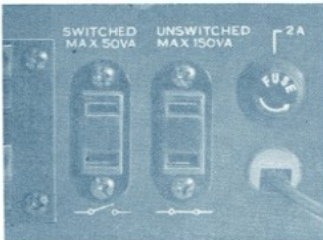

## A.C. Outlets

The AU-777A is provided with two A.C. outlets on its rear panel. One outlet (marked  $\text{---}\text{O}\text{---}\text{O}\text{---}$ ) is switched on and off by the POWER switch on the front panel.

**Caution:** The maximum capacity of this outlet is 50 VA, and the other (marked  $\text{---}\text{O}\text{---}\text{O}\text{---}$ ) is 150 VA. Never use either beyond their rated capacity.

## Microphones

1. The amplifier can accept high-impedance microphones only.
2. Don't use excessively long cable.
3. Since the tone controls can be used separately for each channel, the microphones can be used in the best way even when one is for music and the other for voice. The amplifier will have increasing uses if programs from the microphones are to be recorded on tapes.

## Quick-Acting Fuses

If the power indicator lights up but the set does not play, it may be the result of a blown quick-acting fuse in the power circuit of the power amplifier.

To replace, remove the power plug from its AC outlet. Then remove the bonnet from the AU-777A and check for the blown fuse. Before replacing, check for the source of trouble that has caused the fuse to blow. (See your Service Manual)

*Never use a fuse with a different capacity. The correct capacity is 2 amperes.*

If the new fuse blows as soon as the POWER switch is pushed on, check for the defective power circuit. If the trouble source cannot be located, contact the nearest Sansui dealer or Service Center.

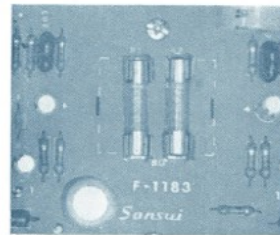

## If the Protector Circuit Lights up...

It means that the AU-777A's circuit has been activated to cut incoming current as soon as it exceeds the allowable limit to prevent the power transistors from becoming damaged. When this happens, the PROTECTOR circuit is closed and no sound comes from the speakers. As soon as this happens, turn off the amplifier's power supply for about 5 seconds, then turn it back on. If all the speakers are still silent, immediately turn the power off, locate and eliminate the source of trouble. Probable cause: a shorted output circuit or excessive input.





## Voltage Selecting Plug

This plug is located inside the bonnet of the amplifier and has been set to the voltage of your area prior to shipment. If the amplifier is ever moved to an area with another voltage requirement, this plug must be changed to the proper voltage of the new area. To change, remove the bonnet from the amplifier, remove the plug from the voltage socket you have been using, and plug the arrow head into the appropriate voltage requirement of 100V, 117V, 220V or 240V.

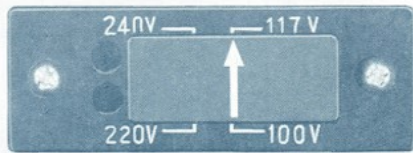

## Grounding

Connect one end of vinyl or enameled wire to the terminal screw marked GND on the rear of the amplifier, attach a copper plate to the other end, and bury it underground. Whenever an outdoor AM antenna is used, grounding becomes necessary. In all cases, grounding is desirable since it allows a better SN ratio to be obtained. To ground an entire audio system, connect the grounding wire of each component used to this terminal.

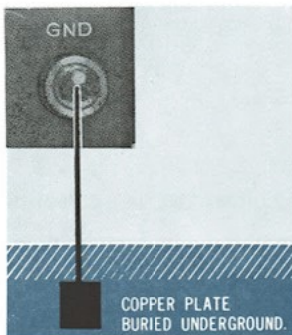

## Where to Place

Since transistors are extremely susceptible to heat, the AU-777A has been designed to diffuse heat through the top and rear of its case. Therefore, special consideration should be given to where it will be used before installing the amplifier. It should not be operated in a place where it is exposed directly to the sun, near radiators or other heat-generating sources, and it should never be mounted in an air-tight cabinet. Finally, nothing should be placed on top of it.

## Connecting Wire

Be sure to use adequately thick shieldwire when connecting a tape recorder, record player or other components to the AU-777A. The use of an ordinary twin leadwire may cause hum or noise. Don't use shieldwire longer than 7 feet (2 meters). The use of a longer wire leads to greater attenuation at high frequencies.

## Connections

Always check to see that leads are connected firmly and properly to their corresponding output or input terminals. If the connections are loose or in touch with other parts, the AU-777A will not perform normally, and may produce undesirable noise. If used in such a way for a long time, it will eventually break down. Always read the manufacturer's instructions for tape recorder, record player, etc. before connecting.

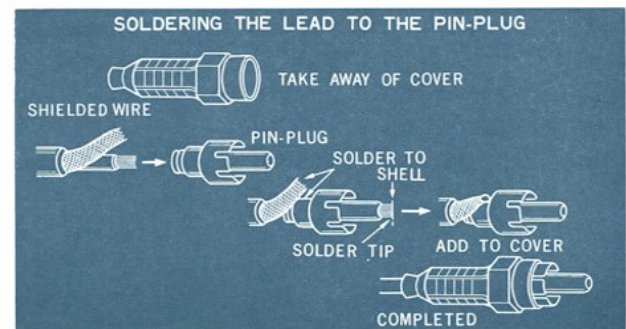

# SPECIFICATIONS

## BASIC AMPLIFIER SECTION

### POWER OUTPUT

MUSIC POWER (IHF): 70 Watts at 8 ohms load

CONTINUOUS POWER (each channel):  
30W/30W at 8 ohms load

TOTAL HARMONIC DISTORTION: less than 0.5% at  
rated output

INTERMODULATION DISTORTION: less than 0.8%  
(60Hz : 7,000Hz = 4 : 1 SMPTE)

POWER BANDWIDTH (IHF): 20 to 50,000Hz at 8 ohms  
load

FREQUENCY RESPONSE: 20 to 100,000Hz  $\pm 1$ dB  
(at normal listening level)

CHANNEL SEPARATION: better than 50dB at rated  
output

HUM AND NOISE (IHF): better than 100dB

INPUT SENSITIVITY: 1V for rated output at 1kHz

LOAD IMPEDANCE: 4 to 16 ohms

DAMPING FACTOR: 15 at 8 ohms

INPUT IMPEDANCE: 300k ohms

### CENTER CHANNEL OUTPUT

FLAT: 10V at 1,000Hz

LOW PASS ( $f_c=159$ Hz): 10V at 50Hz

### SWITCHES

SPEAKER SELECTOR: OFF, SYSTEM-A, SYSTEM-B,  
SYSTEM-A+B

BALANCE CHECK: NORMAL, TEST

## PRE AMPLIFIER SECTION

### OUTPUT VOLTAGE

MAXIMUM OUTPUT VOLTAGE: 4V

RATED OUTPUT VOLTAGE: 1V

TOTAL HARMONIC DISTORTION: less than 0.1% at  
rated output voltage

FREQUENCY RESPONSE: 20 to 70,000Hz  $+0.5 - 1.5$ dB

### HUM AND NOISE (IHF)

PHONO-1 AND 2: better than 80dB at maximum  
output voltage

MIC.: better than 85dB at maximum  
output voltage

TUNER: better than 85dB at maximum  
output voltage

AUX.: better than 85dB at maximum  
output voltage

INPUT SENSITIVITY (for rated output voltage at  
1,000Hz)

PHONO-1: 2mV (50k ohms)

PHONO-2: 2mV (30k, 50k, 100k ohms)

MIC: 3.5mV (50k ohms)

TUNER: 140mV (100k ohms)

AUX: 140mV (100k ohms)

TAPE MON. (PIN): 140mV (100k ohms)

(DIN): 140mV (100k ohms)

### RECORDING OUTPUT

TAPE REC. (PIN): 150mV

TAPE RECORDER (DIN): 30mV

### CONTROLS

BASS:  $\pm 15$ dB at 20Hz (3dB step)

MIDRANGE:  $\pm 5$ dB at 1,500Hz (1dB step)

TREBLE:  $\pm 15$ dB at 20,000Hz (3dB step)

LOUDNESS: +8dB at 50Hz, +2.5dB at  
10,000Hz (volume control at  
-30dB)

### SWITCHES

LOW FILTER: -26dB at 20Hz (12dB/oct)

HIGH FILTER: -18dB at 20,000Hz (12dB/oct)

MUTING SWITCH: -20dB

MODE SWITCH: STEREO-REVERSE, STEREO-  
NORMAL, MONO-L, MONO-  
R, MONO-L+R

TAPE MONITOR: SOURCE, PLAY BACK

SELECTOR: MIC, PHONO-1, PHONO-2,  
TUNER, AUX

EQUALIZER PHONO: RIAA, NF type

MIC.: flat NF type

### OTHER SPECIAL FEATURES

5-pin DIN Socket for Tape Recorder

Head Phone Jack

Protector Circuit and Indicator

POWER REQUIREMENTS: 100, 117, 220, 240, 50/60Hz

POWER CONSUMPTION: 165VA max.

DIMENSIONS: 17  $\frac{1}{8}$ "W, 6  $\frac{1}{8}$ "H, 13  $\frac{1}{8}$ "D

WEIGHT: 27.1 lbs



# CHARACTERISTICS

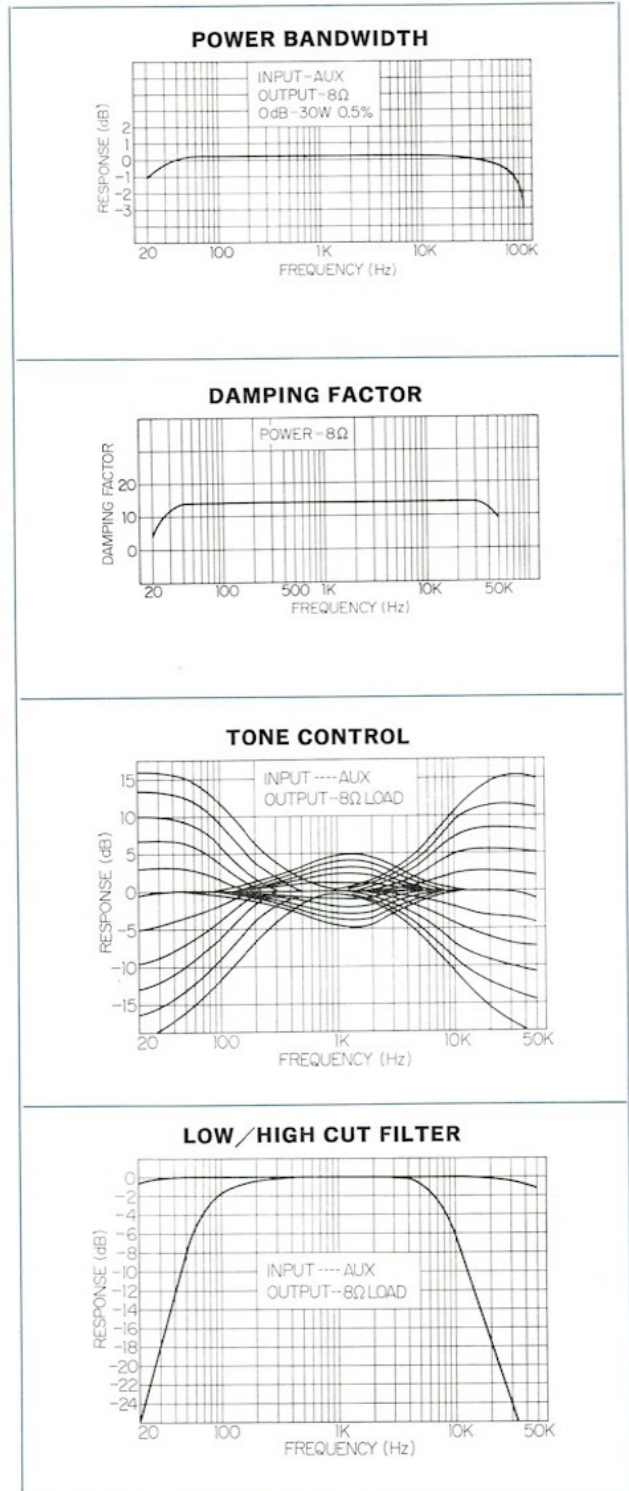
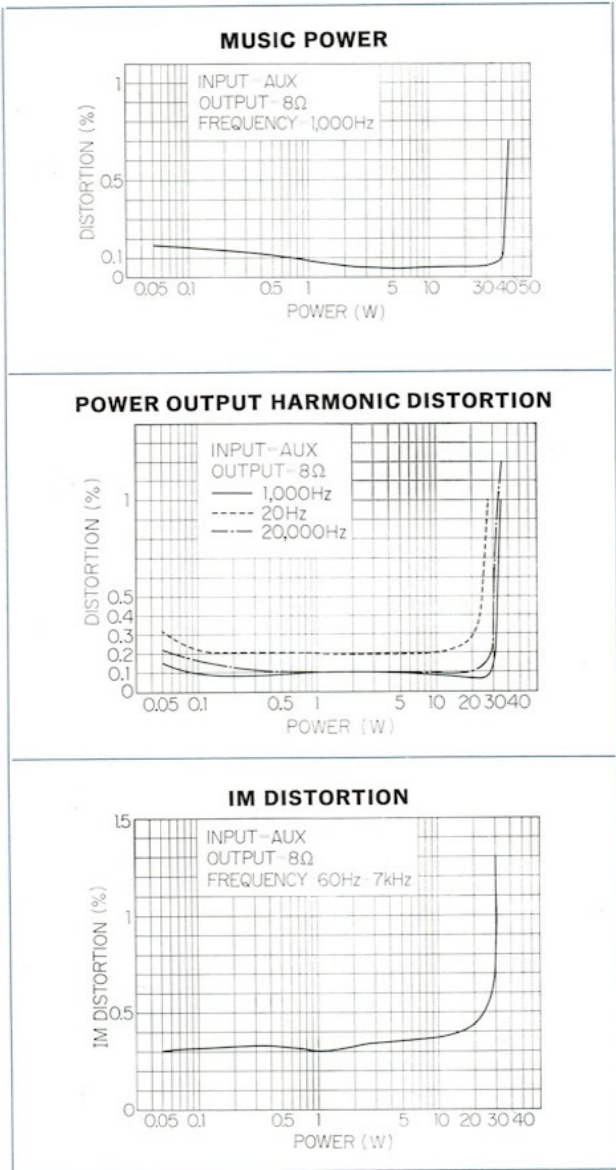

\* All rights reserve specifications subject to change without notice.

# TROUBLESHOOTING CHART

If the amplifier is otherwise operating satisfactorily, the more common causes of trouble may generally be attributed to the following:

1. Incorrect connections or loose terminal contacts. Check the speakers, record player, tape recorder, antenna and line cord.
2. Improper operation. Before operating any audio components, be sure to read the manufacturer's instruc-

tions.

3. Improper location of audio components. The proper positioning of components, such as speakers and turntable, is vital to stereo.

4. Defective audio components.

The following are some other common causes of malfunction and what to do about them.

PROGRAM SOURCE	SYMPTOM	PROBABLE CAUSE	WHAT TO DO
Tuner	Constant or intermittent noise heard at certain times or in a certain area	<ul style="list-style-type: none"> <li>* Discharge or oscillation caused by electrical appliances, such as fluorescent lamp, TV set, D.C. motor, rectifier and oscillator</li> <li>* Natural phenomena, such as atmospheric conditions, static, stray and thunderbolts</li> <li>* Insufficient antenna input due to reinforced concrete walls or long distance from the station</li> <li>* Wave interference from other electrical appliances</li> </ul>	<ul style="list-style-type: none"> <li>* Attach a noise limiter to the electrical appliance that causes the noise, or attach it to the power source of the amplifier.</li> <li>* Install an outdoor antenna and ground the amplifier to raise the signal-to-noise ratio.</li> <li>* Reverse the power cord plug-receptacle connections.</li> <li>* If the noise occurs at a certain frequency, attach a wave trap to the ANT. input.</li> <li>* Keep the set at a proper distance from other electrical appliances.</li> </ul>
	Noise heard at a particular time of a day, in a certain area or over part of the dial during AM reception	<ul style="list-style-type: none"> <li>* This results from the nature of AM broadcast</li> </ul>	<ul style="list-style-type: none"> <li>* Install the antenna for maximum antenna efficiency.</li> <li>* In some cases, the noise can be eliminated by grounding the amplifier or reversing the power cord plug-receptacle connections.</li> </ul>
	High-frequency noise during AM reception	<ul style="list-style-type: none"> <li>* Adjacent-channel interference or beat interference</li> <li>* TV set too close to the audio system</li> </ul>	<ul style="list-style-type: none"> <li>* Although such noise cannot be eliminated by the amplifier, it is advisable to set the TREBLE control to the minimum counterclockwise position possible and switch on the HIGH FILTER.</li> <li>* Keep the TV set at a proper distance from the audio system.</li> </ul>
	Noise during FM reception	<ul style="list-style-type: none"> <li>* Poor noise limiter effect or too low S/N ratio due to insufficient antenna input</li> </ul> <p>Note: FM reception is affected considerably by the broadcasting station's power and antenna efficiency. As a result, you may receive one station quite well while having difficulty in receiving another station.</p>	<ul style="list-style-type: none"> <li>* Install the antenna for maximum signal strength.</li> <li>* If this does not prove effective, use an outdoor antenna designed exclusively for FM. When you use a TV antenna for both TV and FM with the help of a divider, make sure the TV reception is not affected.</li> <li>* An excessive long antenna may cause noise.</li> </ul>
	A series of pops	<ul style="list-style-type: none"> <li>* Ignition noise caused by an auto, motorcycle or the like</li> </ul>	<ul style="list-style-type: none"> <li>* Keep the antenna and its lead-in wire away from heavy traveled roads or raise the antenna input.</li> </ul>



<b>PROGRAM SOURCE</b>	<b>SYMPTOM</b>	<b>PROBABLE CAUSE</b>	<b>WHAT TO DO</b>
(continued)	Noise heard during FM stereo, but not heard during FM mono reception	<ul style="list-style-type: none"> <li>* The service area of the FM stereo broadcast is only half that of the FM mono broadcast</li> </ul>	<ul style="list-style-type: none"> <li>* Install the antenna for maximum antenna input.</li> <li>* Switch on the HIGH FILTER and/or set the TREBLE control to the minimum counterclockwise position possible.</li> </ul>
Record player, tape recorder or tape deck	Hum or howling	<ul style="list-style-type: none"> <li>* Record player placed directly on the speaker box</li> <li>* Use of wire other than shielded wire</li> <li>* Loose terminal contact</li> <li>* Shielded wire too close to the line cord, fluorescent lamp or other electrical appliances</li> <li>* Nearby amateur radio station or TV transmission antenna</li> </ul>	<ul style="list-style-type: none"> <li>* Put a cushion under the record player.</li> <li>* Experiment with several different arrangements before deciding on the final positions of the speaker and record player.</li> <li>* Use a shielded cord for connections.</li> <li>* Switch on the LOW FILTER.</li> <li>* The connecting cord should be as short as possible.</li> <li>* Don't raise the BASS loudness too much.</li> <li>* Consult the nearest Radio Regulatory Bureau.</li> </ul>
	Surface noise	<ul style="list-style-type: none"> <li>* Worn or old record</li> <li>* Worn pick-up needle</li> <li>* Needle covered with dust</li> <li>* Improper needle pressure</li> </ul>	<ul style="list-style-type: none"> <li>* Set the TREBLE control to the minimum counterclockwise position possible and/or switch on the HIGH FILTER.</li> <li>* Clean or replace the needle.</li> </ul>
Common to all program sources	The BALANCE control is not in the mid-position when equal sound comes from both left and right channels.	<ul style="list-style-type: none"> <li>* Due to imperfections in program material, variations in speaker output or asymmetry in room acoustics, the BALANCE control is not always set to the mid-position.</li> </ul>	<ul style="list-style-type: none"> <li>* Set the MODE switches to MONO and adjust the BALANCE control so that the sound is heard from a point midway between the two speakers.</li> </ul>

# DISASSEMBLY PROCEDURE

## How to install the amplifier in a wooden cabinet

1. As illustrated right, make a cabinet window of 425mm or  $16\frac{47}{64}$ " in width and 145mm or  $5\frac{45}{64}$ " in height.
2. Place two square pieces of wood ( $20 \times 20 \times 270$ mm or  $\frac{25}{32} \times \frac{25}{32} \times 10\frac{5}{8}$ " ) for supporting the amplifier in the bottom board of the cabinet.
3. Cut two holes for attachment bolts in the bottom board of the cabinet.
4. Remove the four rubber feet from the amplifier.
5. Slide the amplifier into position through the cabinet window.
6. Make sure the amplifier is in position, then put the washers in the butterfly bolts (supplied) and fix the amplifier to the cabinet with the butterfly bolts.

### NOTE:

When the amplifier is built into the cabinet, the four rubber feet are not used. Retain them for future use.

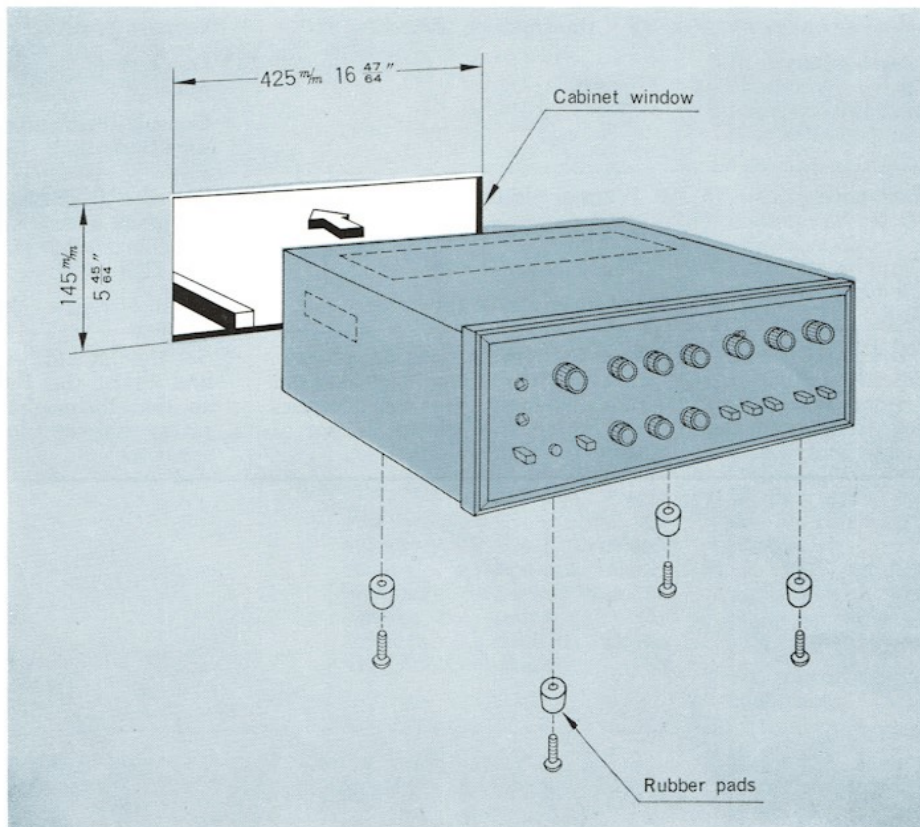



# CUSTOM MOUNTING

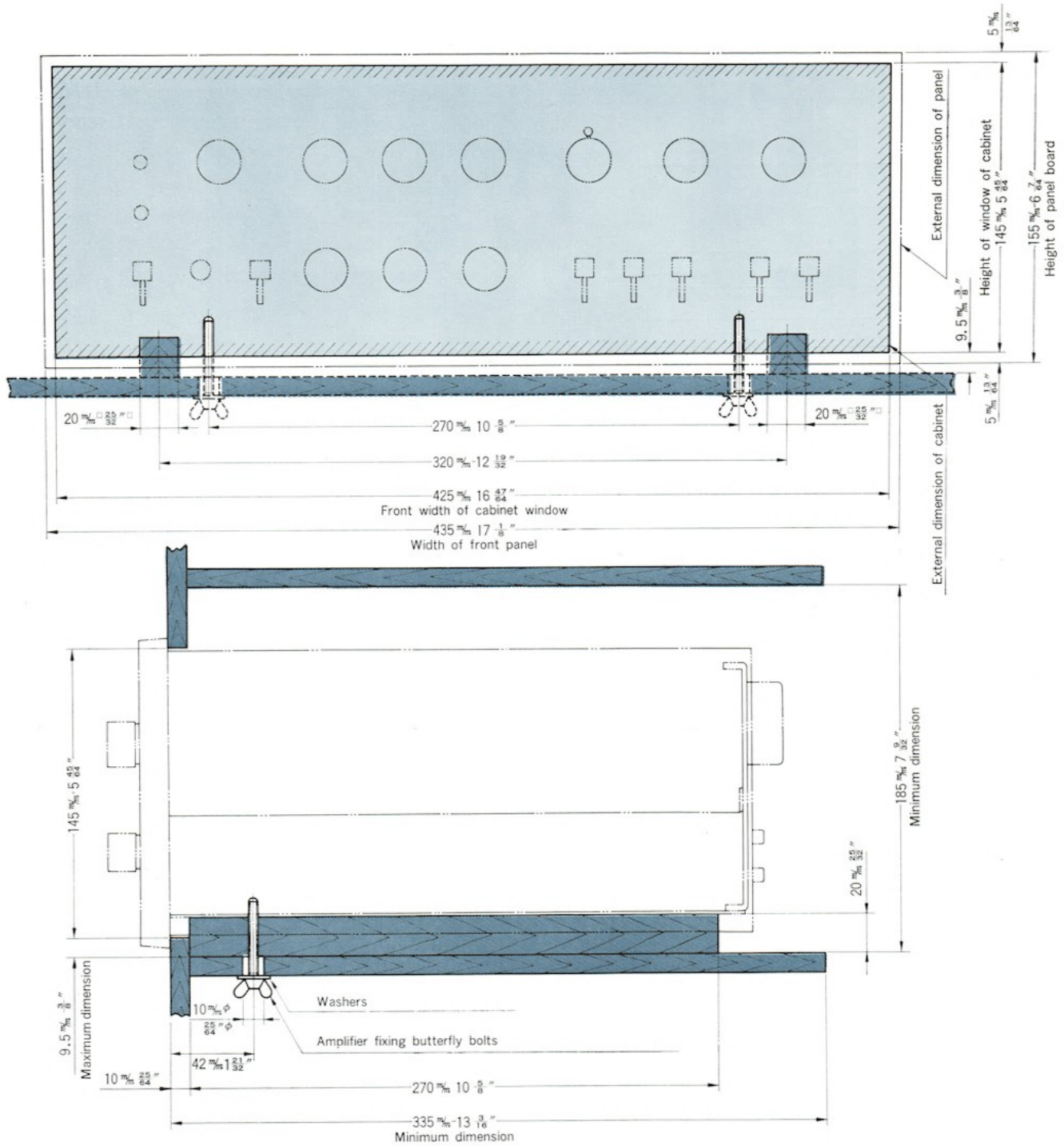

# PARTS LAYOUT

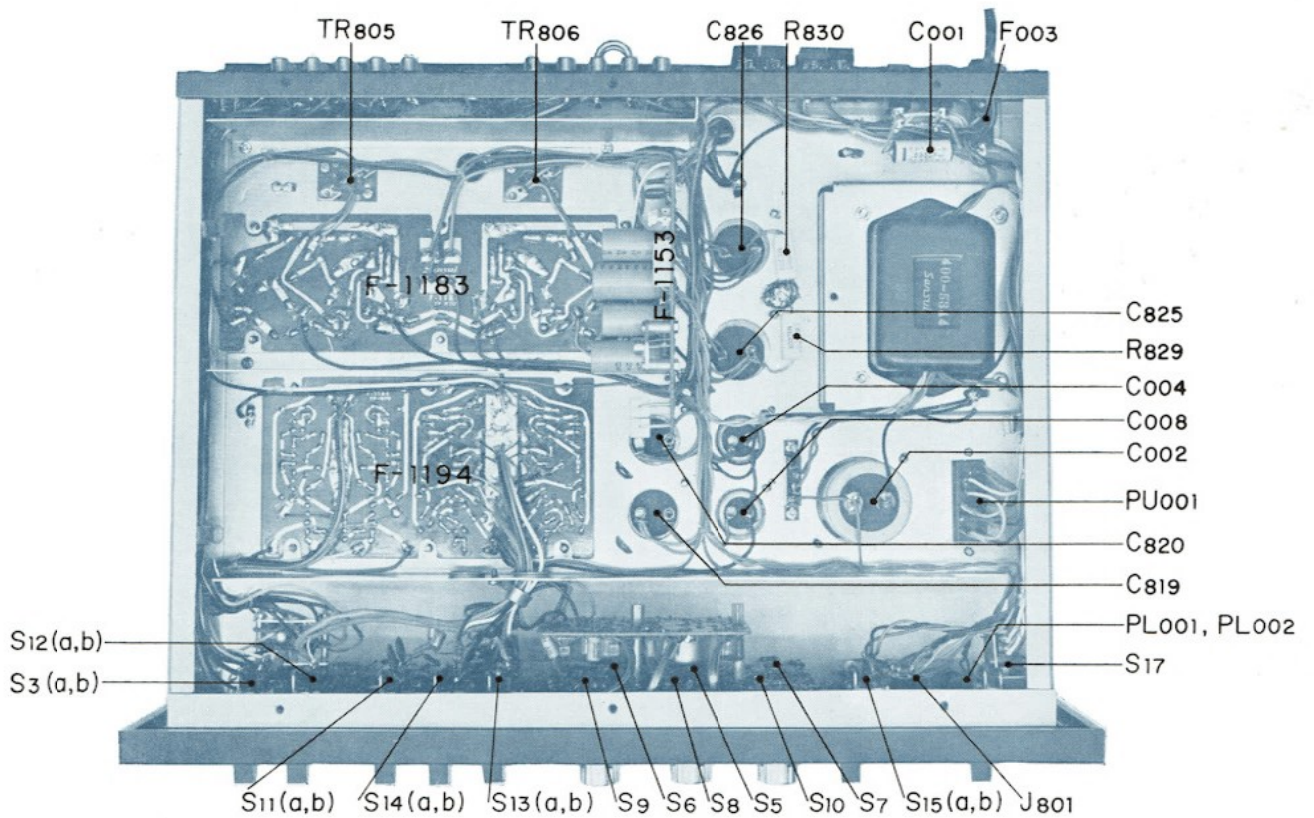
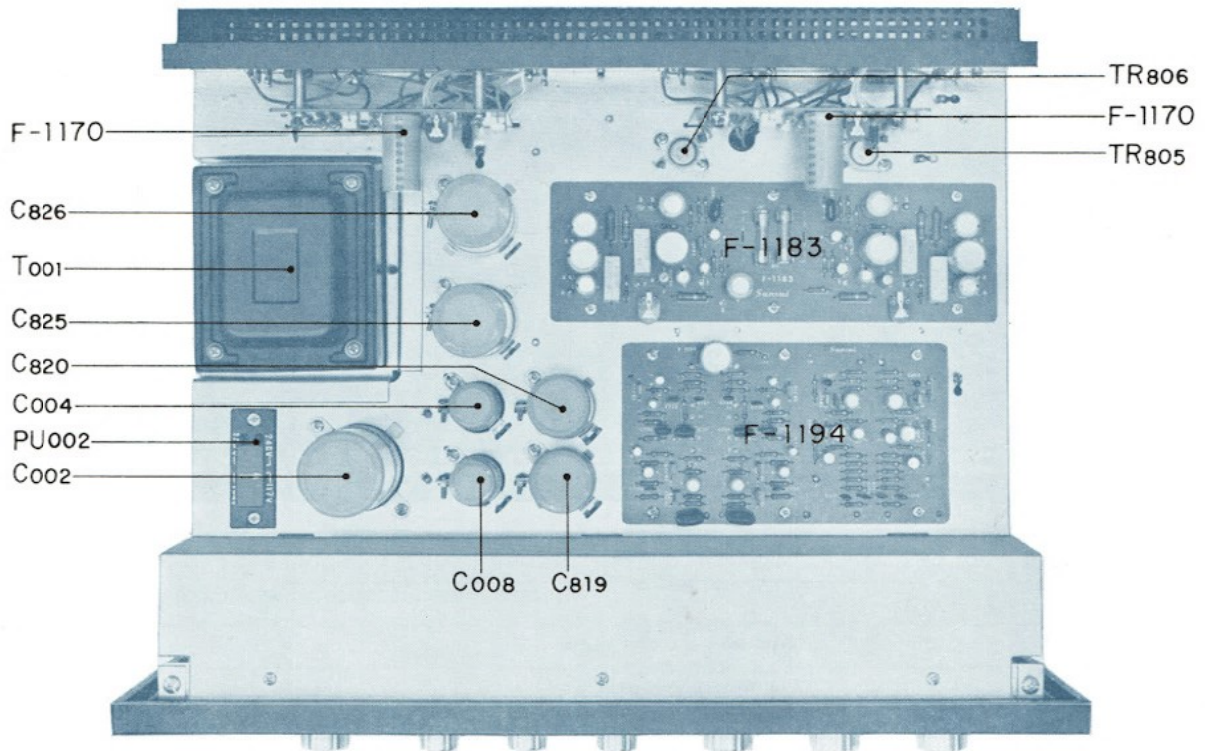





# ALIGNMENT

## TEST POINT

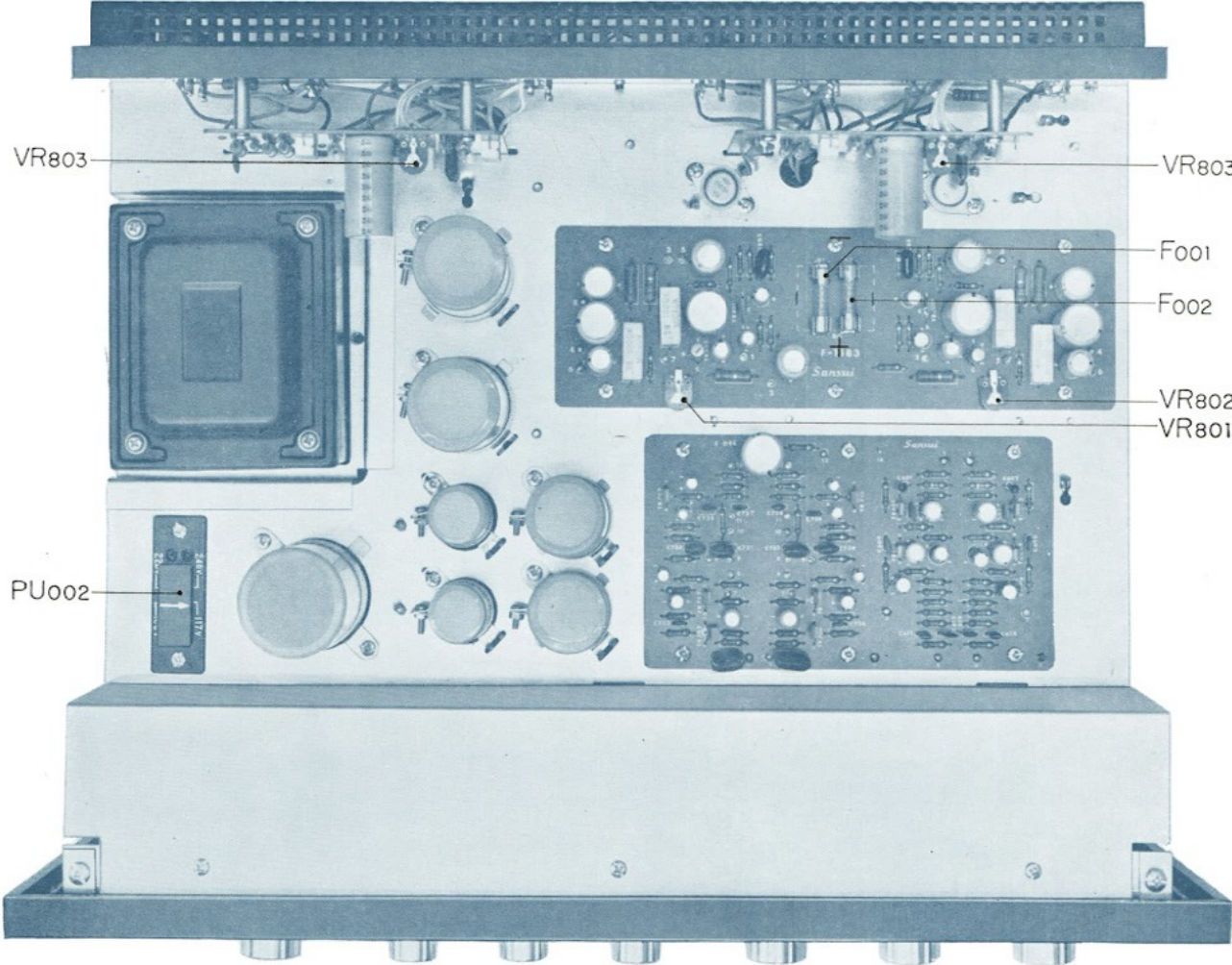

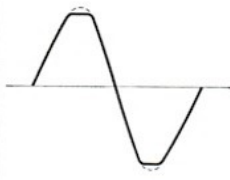

## MAIN-AMP SECTION OUTPUT ADJUSTMENT

STEP	WHAT TO DO	REMARKS
1.	Set VOLUME control to minimum.	Oscilloscope required: oscillation frequency of 20 to 20,000Hz and output voltage of more than 200mV.
2.	Set oscillator to 1,000Hz and connect it to AUX 2 of channel L.	
3.	Set SELECTOR switch to AUX 2	When measuring, BALANCE control to mid-position, TAPE MONITOR switch to SOURCE, MODE switches to STEREO, TONE controls to DEFEAT and other accessory switches to OFF position.
4.	Connect a 8-ohm (or 16-ohm) load resistor (minimum rating of 50 watts) to SYSTEM A LEFT speaker terminal.	
5.	Set SPEAKER selector switch to SYSTEM A.	
6.	Connect oscilloscope to speaker terminal.	
7.	Turn POWER switch ON; turn VOLUME control clockwise little by little; and check output at speaker terminal by using oscilloscope.	
8.	Adjust VR <sub>801</sub> so that both crests of output wave form are clipped.  For channel R, follow same procedure as above. In Step 8, adjust VR <sub>802</sub> for clipped crests of output wave.	

## MAIN-AMP SECTION CURRENT ADJUSTMENT

STEP	AMMETER (TESTER)	WHAT TO DO	REMARKS
1.		Remove F <sub>001</sub> and F <sub>002</sub> .	Ammeter required: 100mA or 50mA range
2.		Set VR <sub>803</sub> to minimum clockwise position.	
3.		Turn POWER switch ON.	
4.	Set to 100mA range.	Set ammeter in place of F <sub>001</sub> . Connect its ⊕ terminal to B <sub>0</sub> , and its ⊖ terminal to B <sub>1</sub> in schematic diagram.	Be sure to turn POWER switch on and then connect ammeter.
5.		Turn VR <sub>803</sub> and adjust current to 28~32mA.	
6.		Turn POWER switch OFF and reset F <sub>001</sub> to its original position.	
7.	Set to 100mA range.	Turn POWER switch ON and set ammeter in place of F <sub>002</sub> . Connect its ⊕ terminal to B <sub>0</sub> , and its ⊖ terminal to B <sub>2</sub> .	
8.		Turn VR <sub>804</sub> and adjust current to 28~32mA.	

# PRINTED CIRCUIT SHEETS AND PARTS LIST

X: Parts No Y: Parts Name Z: Position of Parts

## HEAD PRE-AMP. BLOCK (F-1194)

X	Y	Z
R601	2.2kΩ ¼W ±10% Carbon Resistor R Type	1 C
R602	2.2kΩ ¼W ±10% Carbon Resistor R Type	1 D
R603	680kΩ ¼W ±10% Carbon Resistor R Type	1 C
R604	680kΩ ¼W ±10% Carbon Resistor R Type	1 D
R605	100kΩ ¼W ±10% Carbon Resistor R Type	1 C
R606	100kΩ ¼W ±10% Carbon Resistor R Type	1 D
R607	1.8kΩ ¼W ±10% Carbon Resistor R Type	2 C
R608	1.8kΩ ¼W ±10% Carbon Resistor R Type	2 D
R609	6.8kΩ ¼W ±10% Carbon Resistor R Type	2 C
R610	6.8kΩ ¼W ±10% Carbon Resistor R Type	2 D
R611	390kΩ ¼W ±10% Carbon Resistor R Type	1 C
R612	390kΩ ¼W ±10% Carbon Resistor R Type	1 D
R613	220Ω ¼W ±10% Carbon Resistor R Type	2 C
R614	220Ω ¼W ±10% Carbon Resistor R Type	2 D
R615	680Ω ¼W ±10% Carbon Resistor R Type	2 C
R616	680Ω ¼W ±10% Carbon Resistor R Type	2 D
R617	470Ω ¼W ±10% Carbon Resistor R Type	2 C
R618	470Ω ¼W ±10% Carbon Resistor R Type	2 D
R619	18kΩ ¼W ±10% Carbon Resistor R Type	3 C
R620	18kΩ ¼W ±10% Carbon Resistor R Type	3 D
R621	82kΩ ¼W ±10% Carbon Resistor R Type	3 C
R622	82kΩ ¼W ±10% Carbon Resistor R Type	3 D
R623	4.7kΩ ¼W ±10% Carbon Resistor R Type	3 C
R624	4.7kΩ ¼W ±10% Carbon Resistor R Type	3 D
R625	22kΩ ¼W ±10% Carbon Resistor R Type	3 C
R626	22kΩ ¼W ±10% Carbon Resistor R Type	3 D
R627	270kΩ ¼W ±10% Carbon Resistor R Type	3 C
R628	270kΩ ¼W ±10% Carbon Resistor R Type	3 D
R735	470kΩ ¼W ±10% Carbon Resistor R Type	3 A
R736	470kΩ ¼W ±10% Carbon Resistor R Type	3 B
R737	47kΩ ¼W ±10% Carbon Resistor R Type	3 A
R738	47kΩ ¼W ±10% Carbon Resistor R Type	3 B
R739	1.5kΩ ¼W ±10% Carbon Resistor R Type	3 A
R740	1.5kΩ ¼W ±10% Carbon Resistor R Type	3 B
R741	5.6kΩ ¼W ±10% Carbon Resistor R Type	2 A
R742	5.6kΩ ¼W ±10% Carbon Resistor R Type	2 B
R743	1.5kΩ ¼W ±10% Carbon Resistor R Type	3 A
R744	1.5kΩ ¼W ±10% Carbon Resistor R Type	3 B
R745	27kΩ ¼W ±10% Carbon Resistor R Type	3 A
R746	27kΩ ¼W ±10% Carbon Resistor R Type	3 B
R747	47kΩ ¼W ±10% Carbon Resistor R Type	2 A
R748	47kΩ ¼W ±10% Carbon Resistor R Type	2 B
R749	5.6kΩ ¼W ±10% Carbon Resistor R Type	2 A
R750	5.6kΩ ¼W ±10% Carbon Resistor R Type	2 B
R751	22kΩ ¼W ±10% Carbon Resistor R Type	2 A
R752	22kΩ ¼W ±10% Carbon Resistor R Type	2 B
R753	4.7kΩ 1 W ±10% Metal Film Resistor	1 B
R755	1.2kΩ ¼W ±10% Carbon Resistor R Type	2 A
R756	1.2kΩ ¼W ±10% Carbon Resistor R Type	2 B
R757	3.3kΩ ¼W ±10% Carbon Resistor R Type	2 A
R758	3.3kΩ ¼W ±10% Carbon Resistor R Type	2 B
R759	1kΩ ¼W ±10% Carbon Resistor R Type	2 A
R760	1kΩ ¼W ±10% Carbon Resistor R Type	2 B
R761	100kΩ ¼W ±10% Carbon Resistor R Type	1 A
R762	100kΩ ¼W ±10% Carbon Resistor R Type	1 B
R763	180kΩ ¼W ±10% Carbon Resistor R Type	1 A
R764	180kΩ ¼W ±10% Carbon Resistor R Type	1 B

X	Y	Z
R765	3.3kΩ ¼W ±10% Carbon Resistor R Type	1 A
R766	3.3kΩ ¼W ±10% Carbon Resistor R Type	1 B
R767	47kΩ ¼W ±10% Carbon Resistor R Type	1 A
R768	47kΩ ¼W ±10% Carbon Resistor R Type	1 B
C601	1.5μF 16 WV Tantalum Capacitor	1 C
C602	1.5μF 16 WV Tantalum Capacitor	1 D
C603	150 pF 50 WV ±10% Ceramic Capacitor	1 C
C604	150 pF 50 WV ±10% Ceramic Capacitor	1 D
C605	33μF 10 WV Electrolytic Capacitor	1 C
C606	33μF 10 WV Electrolytic Capacitor	1 D
C607	33μF 10 WV Electrolytic Capacitor	2 C
C608	33μF 10 WV Electrolytic Capacitor	2 D
C609	150 pF 50 WV ±10% Ceramic Capacitor	2 C
C610	150 pF 50 WV ±10% Ceramic Capacitor	2 D
C611	10μF 25 WV Electrolytic Capacitor	2 C
C612	10μF 25 WV Electrolytic Capacitor	2 D
C613	10μF 10 WV Electrolytic Capacitor	2 C
C614	10μF 10 WV Electrolytic Capacitor	2 D
C615	0.012μF 50 WV ±10% Mylar Capacitor	3 C
C616	0.012μF 50 WV ±10% Mylar Capacitor	3 D
C617	0.0033μF 50 WV ±10% Mylar Capacitor	3 C
C618	0.0033μF 50 WV ±10% Mylar Capacitor	3 D
C721	0.22μF 50 WV ±10% Mylar Capacitor	3 A
C722	0.22μF 50 WV ±10% Mylar Capacitor	3 B
C723	33 pF 50 WV ±10% Ceramic Capacitor	3 A
C724	33 pF 50 WV ±10% Ceramic Capacitor	3 B
C725	47μF 6.3 WV Electrolytic Capacitor	3 A
C726	47μF 6.3 WV Electrolytic Capacitor	3 B
C727	10μF 25 WV Electrolytic Capacitor	3 A
C728	10μF 25 WV Electrolytic Capacitor	3 B
C729	1μF 50 WV Electrolytic Capacitor	2 A
C730	1μF 50 WV Electrolytic Capacitor	2 C
C731	0.1μF 50 WV ±10% Mylar Capacitor	2 A
C732	0.1μF 50 WV ±10% Mylar Capacitor	2 B
C733	0.047μF 50 WV ±10% Mylar Capacitor	2 A
C734	0.047μF 50 WV ±10% Mylar Capacitor	2 B
C735	0.015μF 50 WV ±10% Mylar Capacitor	2 A
C736	0.015μF 50 WV ±10% Mylar Capacitor	2 B
C737	0.006μF 50 WV ±10% Mylar Capacitor	1 A
C738	0.006μF 50 WV ±10% Mylar Capacitor	1 B
C739	1μF 50 WV Electrolytic Capacitor	2 A
C740	1μF 50 WV Electrolytic Capacitor	2 B
C741	3.3μF 25 WV Electrolytic Capacitor	1 A
C742	3.3μF 25 WV Electrolytic Capacitor	1 B
C743	470μF 25 WV Electrolytic Capacitor	1 B
TR601	2SC-458LG(B,C) Silicon Transistor (030531-0,1)	1 C
TR602	2SC-458LG(B,C) Silicon Transistor (030531-0,1)	1 D
TR603	2SC-458LG© Silicon Transistor (030531-1)	2 C
TR604	2SC-458LG© Silicon Transistor (030531-1)	2 D
TR705	2SC-458LG(B,C) Silicon Transistor (030531-0,1)	3 A
TR706	2SC-458LG(B,C) Silicon Transistor (030531-0,1)	3 B



X	Y	Z
TR707	2SC-458LG(B,C) Silicon Transistor (030531-0,1)	3 A
TR708	2SC-458LG(B,C) Silicon Transistor (030531-0,1)	3 B

X	Y	Z
TR709	2SC-458LG(B,C) Silicon Transistor (030531-0,1)	1 A
TR710	2SC-458LG(B,C) Silicon Transistor (030531-0,1)	1 C

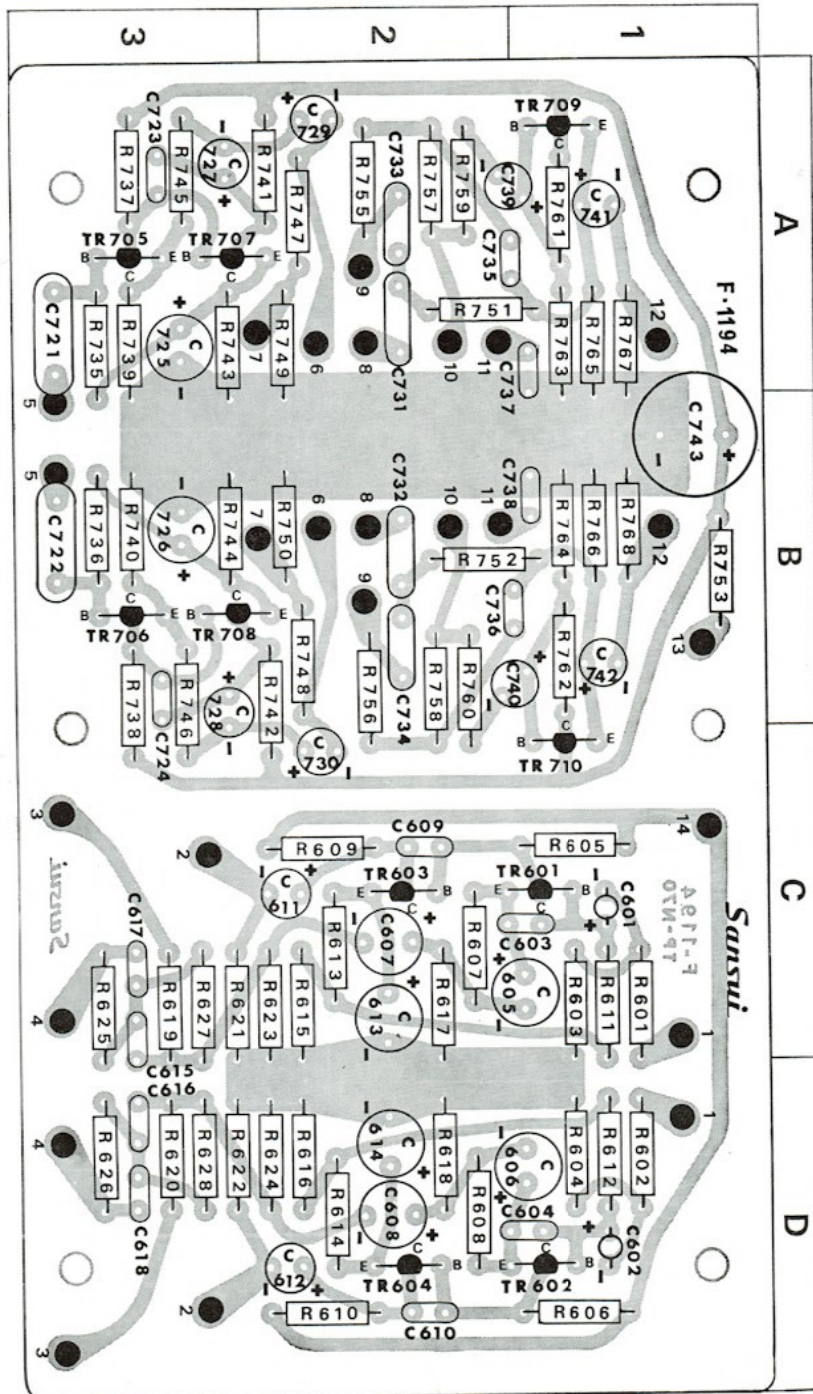

# PRINTED CIRCUIT SHEETS AND PARTS LIST

X: Parts No Y: Parts Name Z: Position of Parts

## STONE CONTROL AMP. BLOCK (F-1207)

X	Y	Z
R701	2.2kΩ ¼W ±10% Carbon Resistor R Type	1 C
R702	2.2kΩ ¼W ±10% Carbon Resistor R Type	2 C
R703	220kΩ ¼W ±10% Carbon Resistor R Type	1 C
R704	220kΩ ¼W ±10% Carbon Resistor R Type	2 C
R705	680kΩ ¼W ±10% Carbon Resistor R Type	1 C
R706	680kΩ ¼W ±10% Carbon Resistor R Type	2 C
R707	8.2kΩ ¼W ±10% Carbon Resistor R Type	1 C
R708	8.2kΩ ¼W ±10% Carbon Resistor R Type	2 C
R709	4.7kΩ ¼W ±10% Carbon Resistor R Type	1 A
R710	4.7kΩ ¼W ±10% Carbon Resistor R Type	2 A
R711	10kΩ ¼W ±10% Carbon Resistor R Type	1 B
R712	10kΩ ¼W ±10% Carbon Resistor R Type	2 B
R713	10kΩ ¼W ±10% Carbon Resistor R Type	1 A
R714	10kΩ ¼W ±10% Carbon Resistor R Type	2 A
R715	3.3kΩ ¼W ±10% Carbon Resistor R Type	1 B
R716	3.3kΩ ¼W ±10% Carbon Resistor R Type	2 B
R717	10kΩ ¼W ±10% Carbon Resistor R Type	1 A
R718	10kΩ ¼W ±10% Carbon Resistor R Type	2 A
R719	4.7kΩ ¼W ±10% Carbon Resistor R Type	1 A
R720	4.7kΩ ¼W ±10% Carbon Resistor R Type	2 A
R721	470kΩ ¼W ±10% Carbon Resistor R Type	1 C
R722	470kΩ ¼W ±10% Carbon Resistor R Type	2 C
R723	10kΩ ¼W ±10% Carbon Resistor R Type	1 B
R724	10kΩ ¼W ±10% Carbon Resistor R Type	2 B
R725	560kΩ ¼W ±10% Carbon Resistor R Type	1 C
R726	560kΩ ¼W ±10% Carbon Resistor R Type	2 C
R727	330kΩ ¼W ±10% Carbon Resistor R Type	1 B
R728	330kΩ ¼W ±10% Carbon Resistor R Type	2 B
R729	5.6kΩ ¼W ±10% Carbon Resistor R Type	1 C
R730	5.6kΩ ¼W ±10% Carbon Resistor R Type	2 C
R731	3.3kΩ ¼W ±10% Carbon Resistor R Type	1 C
R732	3.3kΩ ¼W ±10% Carbon Resistor R Type	2 C
R733	5.6kΩ ¼W ±10% Carbon Resistor R Type	1 C

X	Y	Z
R734	5.6kΩ ¼W ±10% Carbon Resistor R Type	2 C
C701	1μF 50 WV Electrolytic Capacitor	1 C
C702	1μF 50 WV Electrolytic Capacitor	2 C
C703	10μF 25 WV Electrolytic Capacitor	1 C
C704	10μF 25 WV Electrolytic Capacitor	2 C
C705	0.01μF 50 WV ±10% Mylar Capacitor	1 B
C706	0.01μF 50 WV ±10% Mylar Capacitor	2 B
C707	0.0022μF 50 WV ±10% Mylar Capacitor	1 B
C708	0.0022μF 50 WV ±10% Mylar Capacitor	2 B
C709	0.068μF 50 WV ±10% Mylar Capacitor	1 A
C710	0.068μF 50 WV ±10% Mylar Capacitor	2 A
C711	0.068μF 50 WV ±10% Mylar Capacitor	1 A
C712	0.068μF 50 WV ±10% Mylar Capacitor	2 A
C713	3.3μF 25 WV Electrolytic Capacitor	1 B
C714	3.3μF 25 WV Electrolytic Capacitor	2 B
C715	47μF 6.3 WV Electrolytic Capacitor	1 B
C716	47μF 6.3 WV Electrolytic Capacitor	2 B
C717	47 pF 50 WV ±10% Ceramic Capacitor	1 B
C718	47 pF 50 WV ±10% Ceramic Capacitor	2 B
C719	10μF 25 WV Electrolytic Capacitor	1 C
C720	10μF 25 WV Electrolytic Capacitor	2 C
L701	0.8H Choke Coil (401003)	1 A
L702	0.8H Choke Coil (401003)	2 A
TR701	2SC-458 LG(B, C) Silicon Transistor (030531-0,1)	1 C
TR702	2SC-458 LG(B, C) Silicon Transistor (030531-0,1)	2 C
TR703	2SC-458 LG(B, C) Silicon Transistor (030531-0,1)	1 B
TR704	2SC-458 LG(B, C) Silicon Transistor (030531-0,1)	2 B

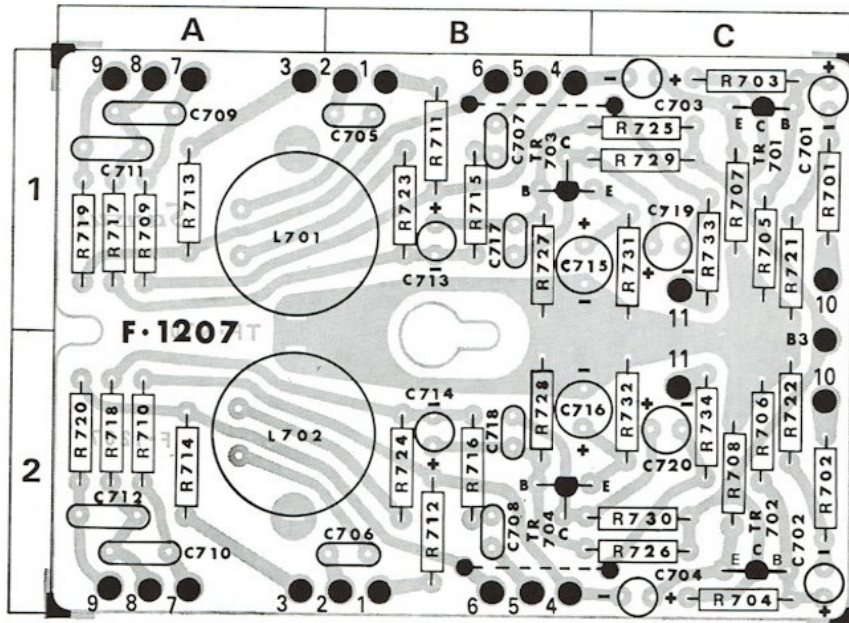



# DRIVER AMP. BLOCK (F-1183-1)

X	Y	Z
R801	47kΩ ¼W ±10% Carbon Resistor R Type	2 B
R802	47kΩ ¼W ±10% Carbon Resistor R Type	2 C
R803	47kΩ ¼W ±10% Carbon Resistor R Type	2 B
R804	47kΩ ¼W ±10% Carbon Resistor R Type	2 C
R805	47kΩ ¼W ±10% Carbon Resistor R Type	1 B
R806	47kΩ ¼W ±10% Carbon Resistor R Type	1 C
R807	8.2kΩ ¼W ±10% Carbon Resistor R Type	1 B
R808	8.2kΩ ¼W ±10% Carbon Resistor R Type	1 C
R809	2.2kΩ ½W ±10% Carbon Resistor RD Type	2 B
R810	2.2kΩ ½W ±10% Carbon Resistor RD Type	2 C
R811	100Ω ¼W ±10% Carbon Resistor R Type	1 B
R812	100Ω ¼W ±10% Carbon Resistor R Type	1 C
R813	22Ω ¼W ±10% Carbon Resistor R Type	1 B
R814	22Ω ¼W ±10% Carbon Resistor R Type	1 C
R817	10kΩ ¼W ±10% Carbon Resistor R Type	2 A
R818	10kΩ ¼W ±10% Carbon Resistor R Type	2 D
R819	100Ω 3 W Cement Resistor (012033)	1, 2 A
R820	100Ω 3 W Cement Resistor (012033)	1, 2 D
R821	100Ω 3 W Cement Resistor (012033)	2 A
R822	100Ω 3 W Cement Resistor (012033)	2 D
R823	10kΩ ¼W ±10% Carbon Resistor R Type	2 A
R824	10kΩ ¼W ±10% Carbon Resistor R Type	2 D
R825	330Ω ½W ±10% Carbon Resistor RD Type	1 A
R826	330Ω ½W ±10% Carbon Resistor RD Type	1 D
R827	6.8kΩ ¼W ±10% Carbon Resistor R Type	2 C
C801	10μF 10 WV Electrolytic Capacitor	2 B
C802	10μF 10 WV Electrolytic Capacitor	2 C
C803	470pF 50 WV Mica Capacitor	1 B
C804	470pF 50 WV Mica Capacitor	1 C
C805	10μF 25 WV Electrolytic Capacitor	1 B
C806	10μF 25 WV Electrolytic Capacitor	1 C
C807	3.3μF 15 WV Electrolytic Capacitor	2 B
C808	3.3μF 15 WV Electrolytic Capacitor	2 C
C809	47μF 50 WV Electrolytic Capacitor	2 B
C811	1000μF 6.3 WV Electrolytic Capacitor	1 B
C812	1000μF 6.3 WV Electrolytic Capacitor	1 C
C815	1000μF 6.3 WV Electrolytic Capacitor	2 A
C816	1000μF 6.3 WV Electrolytic Capacitor	2 D
C821	100μF 25 WV Electrolytic Capacitor	2 A
C822	100μF 25 WV Electrolytic Capacitor	2 D
VR801	50kΩ(B) AC Balance ADJUSTMENT (103020)	2 A
VR802	50kΩ(B) AC Balance ADJUSTMENT (103020)	2 D
TR801	2SC-458LG(B,C) Silicon Transistor (030531-0,1)	1 B
TR802	2SC-458LG(B,C) Silicon Transistor (030531-0,1)	1 C
TR803	2SC-283 Silicon Transistor (030513)	2 A
TR804	2SC-283 Silicon Transistor (030513)	2 D
F001	2A Quick Acting Fuse (043008)	1 B
F002	2A Quick Acting Fuse (043008)	1 C

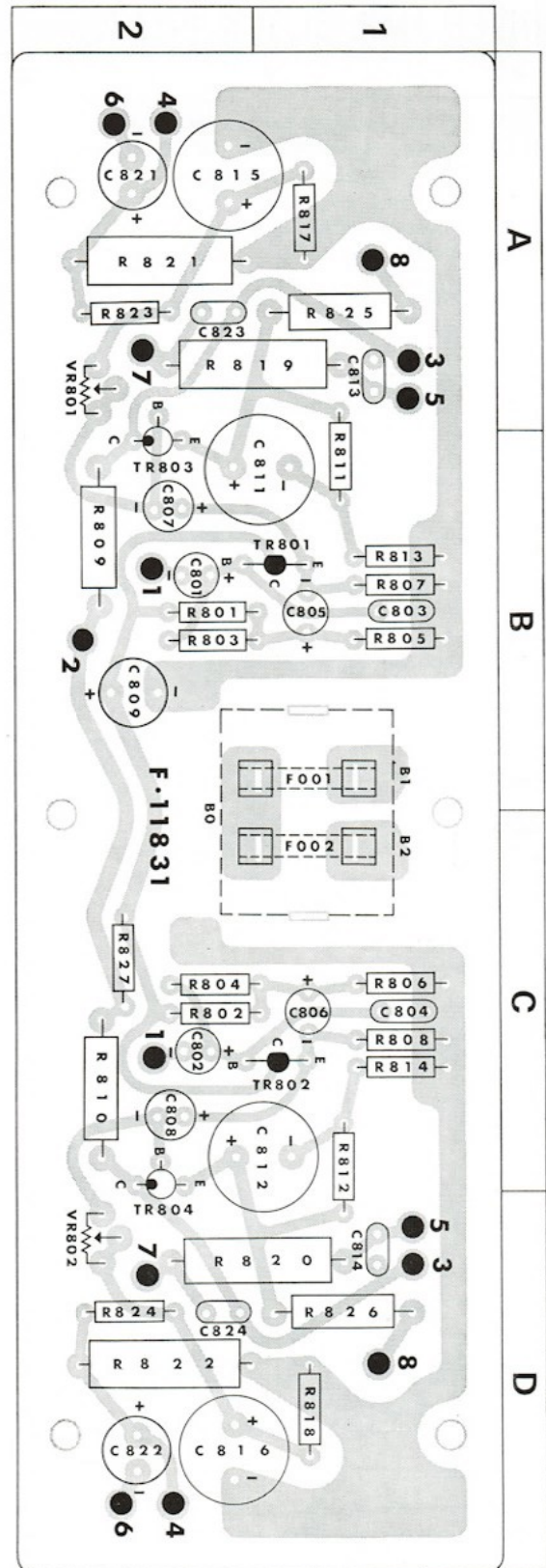

# PRINTED CIRCUIT SHEETS AND PARTS LIST

X: Parts No Y: Parts Name Z: Position of Parts

## DRIVER AMP. BLOCK (F-1170)

X	Y	Z
R831	3.9kΩ 2 W Metal Film Resistor	1 A
R833	150Ω 1/2W ±10% Carbon Resistor RD Type	1 A
R835	33Ω 1/2W ±10% Carbon Resistor RD Type	2 B
R837	3.9kΩ 2 W Metal Film Resistor	1 A
R839	150Ω 1/4W ±10% Carbon Resistor R Type	1 B
R841	3.3kΩ 1/4W ±10% Carbon Resistor R Type	1 B
R843	100Ω 1/2W ±10% Carbon Resistor RD Type	1 A
R845	100Ω 1/2W ±10% Carbon Resistor RD Type	1 B
R851	0.5Ω 2 W Cement Resistor (012049)	1 A
R853	0.5Ω 2 W Cement Resistor (012049)	1 B
R855	6.8Ω 3 W Cement Resistor (012031)	2 B
R857	33Ω 1/4W ±10% Carbon Resistor R Type	1 A
R861	3.3Ω 1/4W ±10% Carbon Resistor R Type	1 B
C817	470μF 35 WV Electrolytic Capacitor	1 B
C827	0.1μF 50 WV Mylar Capacitor	2 B
C829	0.01μF 250WV Ceramic Capacitor	2 A
L801	0.8μH Choke	1 A
L803	0.8μH Choke	2 B
VR803	1kΩ(B) DC Bias ADJUSTMENT (103053)	1 B
TR815	2SC-281(B, C) (030512-1,2)	1 B

## POWER & PROTECTOR BLOCK (F-1153)

X	Y	Z
R001	1.5kΩ 1/2W Carbon Resistor RD Type	1 C
R002	3.9kΩ 1/2W Carbon Resistor RD Type	1 C
R003	1kΩ 1/2W Carbon Resistor RD Type	1 B
R004	1kΩ 1/4W Carbon Resistor R Type	2 D
R005	220Ω 5 W Cement Resistor	1 D
R006	220Ω 5 W Cement Resistor	1 D
R007	330Ω 3 W Cement Resistor	1 B
R008	2.2kΩ 1/4W Carbon Resistor R Type	2 A
R009	2.2kΩ 1/4W Carbon Resistor R Type	2 A
R010	4.7kΩ 1/4W Carbon Resistor R Type	2 A
R011	10kΩ 1/4W Carbon Resistor R Type	1 A
R012	10kΩ 1/4W Carbon Resistor R Type	1 A
C003	220μF 50 WV Electrolytic Capacitor	2 C
C005	470μF 35 WV Electrolytic Capacitor	2 B
C006	200μF 75 WV Electrolytic Capacitor	2 C
C007	220μF 50 WV Electrolytic Capacitor	2 B
C009	0.068μF 50 WV Mylar Capacitor	1 A
C010	0.033μF 50 WV Mylar Capacitor	1 A
VR001	2kΩ(B) PROTECTOR Circuit ADJUSTMENT (103039)	1 A
SCR001	2SF-656 SCR (035002)	1 A
TR001	2SD-224 Silicon Transistor (030823)	1 C
D002	10D-1 Silicon Diode (031034)	1 B
D003	10D-1 Silicon Diode (031034)	1 B
D004	0A91 Germanium Diode (031011)	1 A
D005	0A91 Germanium Diode (031011)	1 A

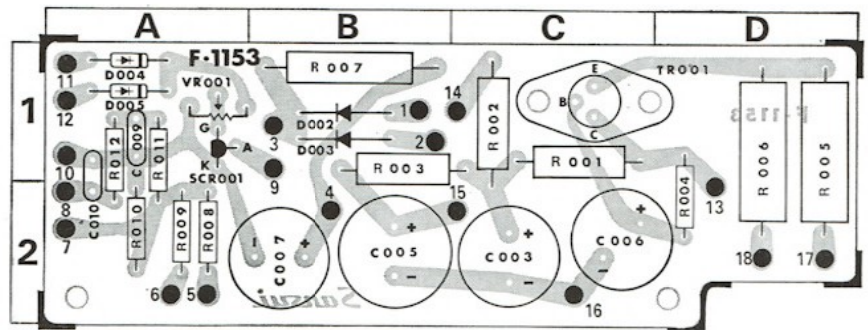
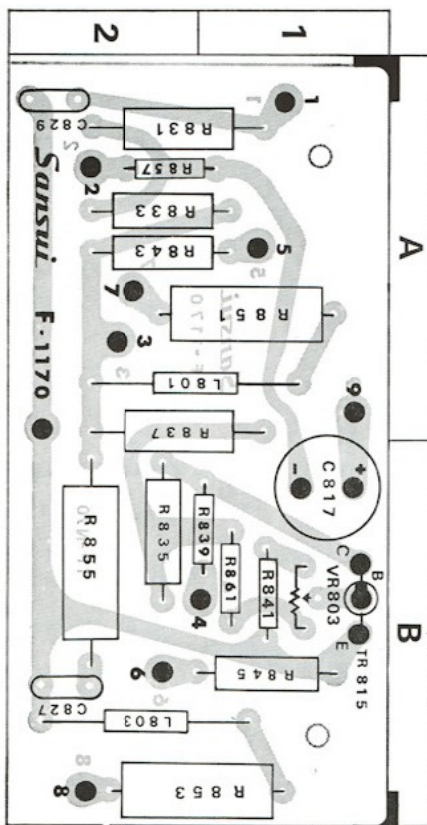



# OTHER PARTS CHART AND LIST

X: Parts No Y: Parts Name

## OTHER PARTS LIST

X	Y
R629	100Ω ¼W ±10% Carbon Resistor R Type
R630	100Ω ¼W ±10% Carbon Resistor R Type
R631	8.2kΩ ¼W ±10% Carbon Resistor R Type
R632	8.2kΩ ¼W ±10% Carbon Resistor R Type
R633	68kΩ ¼W ±10% Carbon Resistor R Type
R634	68kΩ ¼W ±10% Carbon Resistor R Type
R635	180kΩ ¼W ±10% Carbon Resistor R Type
R636	180kΩ ¼W ±10% Carbon Resistor R Type
R637	470kΩ ¼W ±10% Carbon Resistor R Type
R638	470kΩ ¼W ±10% Carbon Resistor R Type
R639	39kΩ ¼W ±10% Carbon Resistor R Type
R640	39kΩ ¼W ±10% Carbon Resistor R Type
R641	56kΩ ¼W ±10% Carbon Resistor R Type
R642	56kΩ ¼W ±10% Carbon Resistor R Type
R643	100kΩ ¼W ±10% Carbon Resistor R Type
R644	100kΩ ¼W ±10% Carbon Resistor R Type
R645	270kΩ ¼W ±10% Carbon Resistor R Type
R646	270kΩ ¼W ±10% Carbon Resistor R Type
R647	68kΩ ¼W ±10% Carbon Resistor R Type
R648	68kΩ ¼W ±10% Carbon Resistor R Type
R769	820kΩ ¼W ±10% Carbon Resistor R Type
R770	820kΩ ¼W ±10% Carbon Resistor R Type
R771	3.3kΩ ¼W ±10% Carbon Resistor R Type
R772	3.3kΩ ¼W ±10% Carbon Resistor R Type
R773	4.7kΩ ¼W ±10% Carbon Resistor R Type
R774	4.7kΩ ¼W ±10% Carbon Resistor R Type
R775	5.6kΩ ¼W ±10% Carbon Resistor R Type
R776	5.6kΩ ¼W ±10% Carbon Resistor R Type
R777	8.2kΩ ¼W ±10% Carbon Resistor R Type
R778	8.2kΩ ¼W ±10% Carbon Resistor R Type
R779	8.2kΩ ¼W ±10% Carbon Resistor R Type
R780	8.2kΩ ¼W ±10% Carbon Resistor R Type
R781	8.2kΩ ¼W ±10% Carbon Resistor R Type
R782	8.2kΩ ¼W ±10% Carbon Resistor R Type
R783	8.2kΩ ¼W ±10% Carbon Resistor R Type
R784	8.2kΩ ¼W ±10% Carbon Resistor R Type
R785	5.6kΩ ¼W ±10% Carbon Resistor R Type
R786	5.6kΩ ¼W ±10% Carbon Resistor R Type
R787	4.7kΩ ¼W ±10% Carbon Resistor R Type
R788	4.7kΩ ¼W ±10% Carbon Resistor R Type
R789	3.3kΩ ¼W ±10% Carbon Resistor R Type
R790	3.3kΩ ¼W ±10% Carbon Resistor R Type
R791	1.8kΩ ¼W ±10% Carbon Resistor R Type
R792	1.8kΩ ¼W ±10% Carbon Resistor R Type
R793	2.7kΩ ¼W ±10% Carbon Resistor R Type
R794	2.7kΩ ¼W ±10% Carbon Resistor R Type
R795	3.9kΩ ¼W ±10% Carbon Resistor R Type
R796	3.9kΩ ¼W ±10% Carbon Resistor R Type
R797	5.6kΩ ¼W ±10% Carbon Resistor R Type
R798	5.6kΩ ¼W ±10% Carbon Resistor R Type
R799	8.2kΩ ¼W ±10% Carbon Resistor R Type
R7100	8.2kΩ ¼W ±10% Carbon Resistor R Type
R7101	8.2kΩ ¼W ±10% Carbon Resistor R Type
R7102	8.2kΩ ¼W ±10% Carbon Resistor R Type
R7103	5.6kΩ ¼W ±10% Carbon Resistor R Type
R7104	5.6kΩ ¼W ±10% Carbon Resistor R Type
R7105	3.9kΩ ¼W ±10% Carbon Resistor R Type

X	Y
R7106	3.9kΩ ¼W ±10% Carbon Resistor R Type
R7107	2.7kΩ ¼W ±10% Carbon Resistor R Type
R7108	2.7kΩ ¼W ±10% Carbon Resistor R Type
R7109	1.8kΩ ¼W ±10% Carbon Resistor R Type
R7110	1.8kΩ ¼W ±10% Carbon Resistor R Type
R7111	2.2kΩ ¼W ±10% Carbon Resistor R Type
R7112	2.2kΩ ¼W ±10% Carbon Resistor R Type
R7113	3.3kΩ ¼W ±10% Carbon Resistor R Type
R7114	3.3kΩ ¼W ±10% Carbon Resistor R Type
R7115	3.9kΩ ¼W ±10% Carbon Resistor R Type
R7116	3.9kΩ ¼W ±10% Carbon Resistor R Type
R7117	6.8kΩ ¼W ±10% Carbon Resistor R Type
R7118	6.8kΩ ¼W ±10% Carbon Resistor R Type
R7119	6.8kΩ ¼W ±10% Carbon Resistor R Type
R7120	6.8kΩ ¼W ±10% Carbon Resistor R Type
R7121	6.8kΩ ¼W ±10% Carbon Resistor R Type
R7122	6.8kΩ ¼W ±10% Carbon Resistor R Type
R7123	5.6kΩ ¼W ±10% Carbon Resistor R Type
R7124	5.6kΩ ¼W ±10% Carbon Resistor R Type
R7125	3.9kΩ ¼W ±10% Carbon Resistor R Type
R7126	3.9kΩ ¼W ±10% Carbon Resistor R Type
R7127	3.3kΩ ¼W ±10% Carbon Resistor R Type
R7128	3.3kΩ ¼W ±10% Carbon Resistor R Type
R7129	2.2kΩ ¼W ±10% Carbon Resistor R Type
R7130	2.2kΩ ¼W ±10% Carbon Resistor R Type
R7131	820kΩ ¼W ±10% Carbon Resistor R Type
R7132	820kΩ ¼W ±10% Carbon Resistor R Type
R7133	6.8kΩ ¼W ±10% Carbon Resistor R Type
R7134	6.8kΩ ¼W ±10% Carbon Resistor R Type
C619	1μF 50WV Electrolytic Capacitor
C620	1μF 50WV Electrolytic Capacitor
C745	820pF Styrol Capacitor
C746	820pF Styrol Capacitor
C747	0.047μF 50WV Mylar Capacitor
C748	0.047μF Mylar Capacitor
VR701	Three Gang Variable Resistor (105001)
VR702	50kΩ(B) } Volume Controls }
VR703	50kΩ(B) } 50kΩ(W) } Balance Control }
R829	150Ω 5 W Cement Resistor (012052)
R830	150Ω 5 W Cement Resistor (012052)
R847	10Ω ½W ±10% Carbon Resistor RD Type
R848	10Ω ½W ±10% Carbon Resistor RD Type
R849	10Ω ½W ±10% Carbon Resistor RD Type
R850	10Ω ½W ±10% Carbon Resistor RD Type
R859	470Ω 2 W Metal Film Resistor
R860	470Ω 2 W Metal Film Resistor
C819	2200μF 35 WV Electrolytic Capacitor (020527)
C820	2200μF 35 WV Electrolytic Capacitor (020527)
C825	1000μF 6.3 WV Electrolytic Capacitor (020518)
C826	1000μF 6.3 WV Electrolytic Capacitor (020518)
C001	0.033μF 600 WV Oil Capacitor
C002	4000μF 80 WV Electrolytic Capacitor (020515)
C004	1000μF 35 WV Electrolytic Capacitor (020528)

# OTHER PARTS CHART AND LIST

X: Parts No Y: Parts Name

X	Y
C008	470 $\mu$ F 50WV Electrolytic Capacitor (020525)
D001	5B-3 Silicon Diode (031066)
PL001	8V 0.15A Pilot Lamp (040005)
PL002	25V 90mA Protector Lamp (040007)
PU001	Power Voltage Selector Socket (241008)
PU002	Power Voltage Selector Plug (241009)
T001	Power Transformer (400-5344)
F003	2A Fuse (043003)
CO001	AC Outlet (245001)
CO002	AC Outlet (245001)

X	Y
S1(a~f)	Selector Switch (110319)
S2(a,b)	Pick-up Load Switch (111011)
S3(a,b)	Tape Monitor (117007)
S4(a~c)	Mode Switch (110113)
S5	Tone Control, Midrange (110115)
S6	Tone Control, Treble (110112)
S7	Tone Control, Bass (110112)
S8	Tone Control, Midrange (110115)
S9	Tone Control, Treble (110112)
S10	Tone Control, Bass (110112)
S11(a,b)	Loudness (117003)
S12(a,b)	Muting (117003)
S13(a,b)	Low Filter (117003)
S14(a,b)	High Filter (117003)
S15(a,b)	Balance Check (117003)
S16(a~d)	Speaker Selector (110114)
S17	Power Switch (117005)

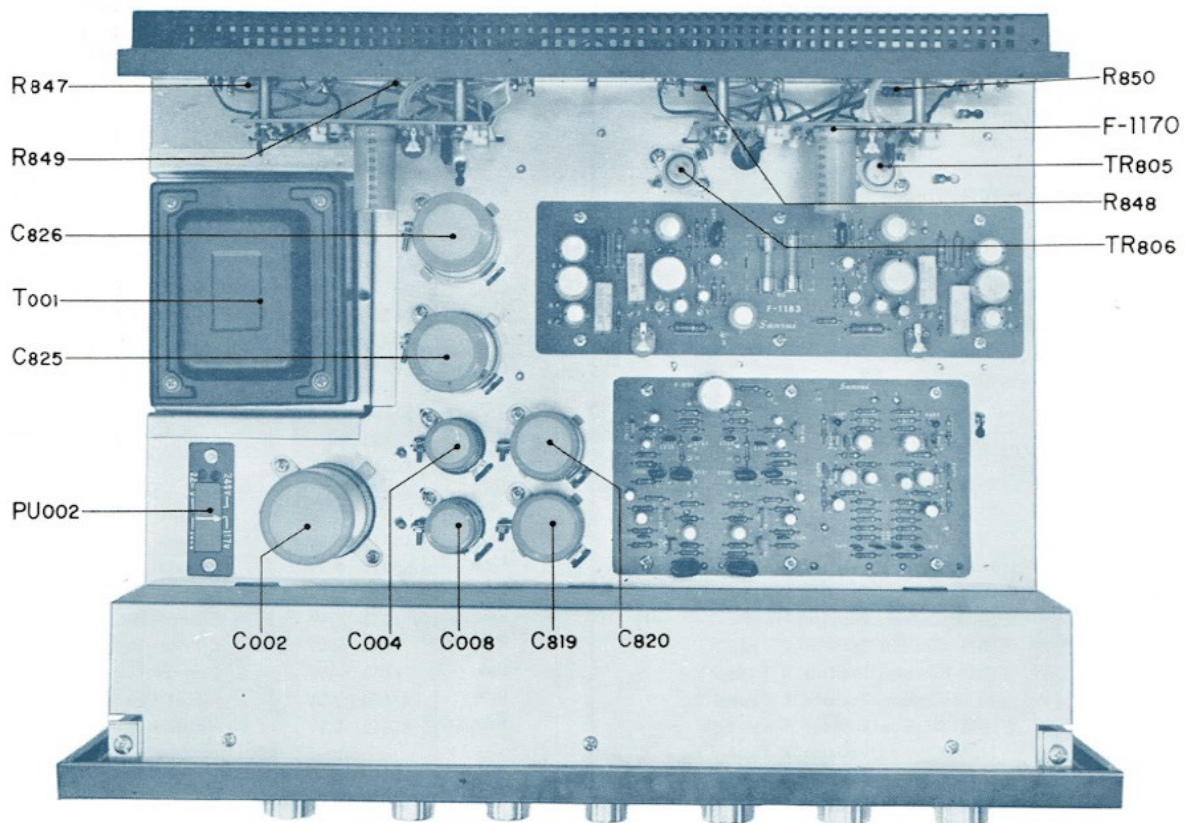



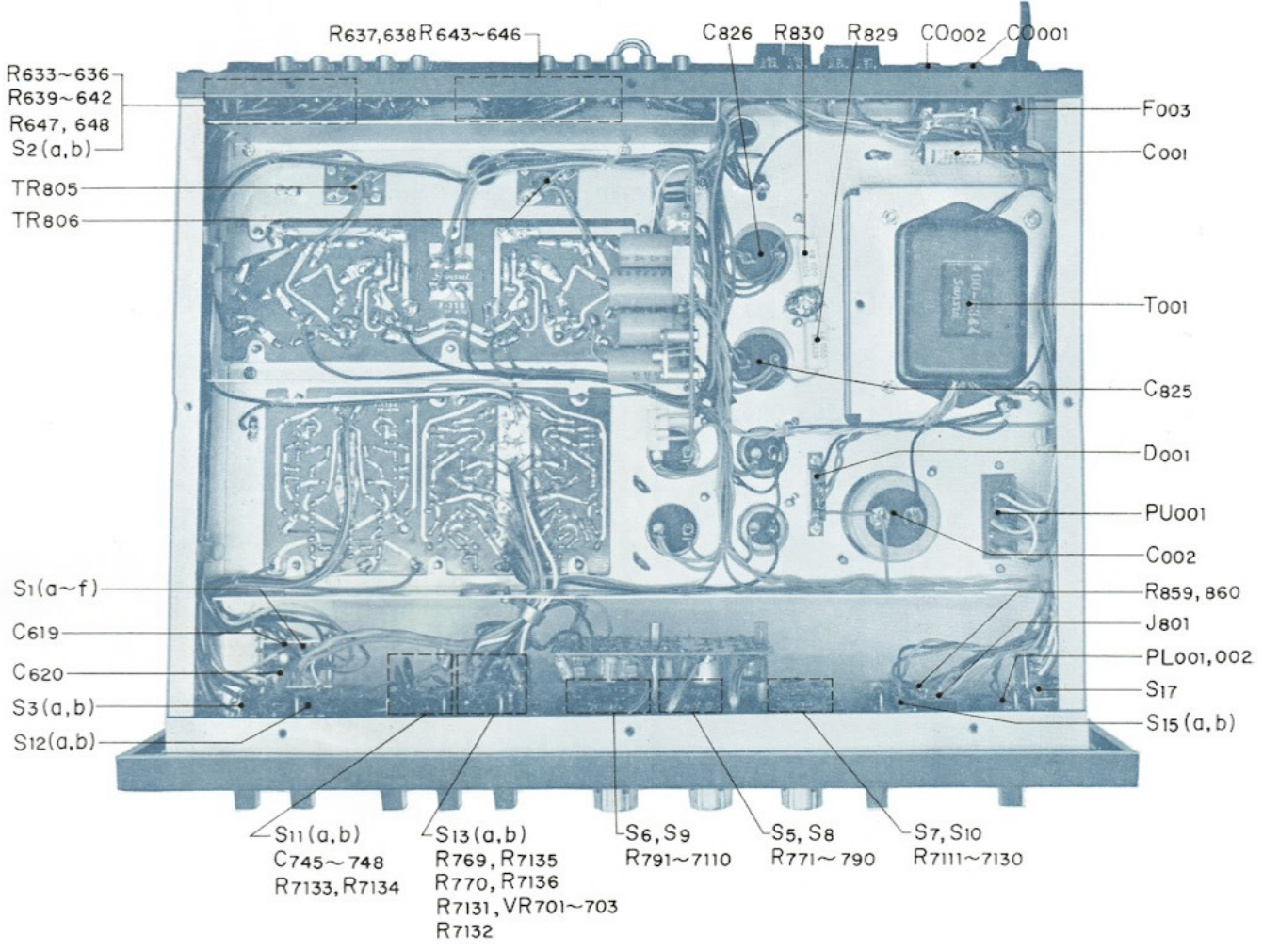
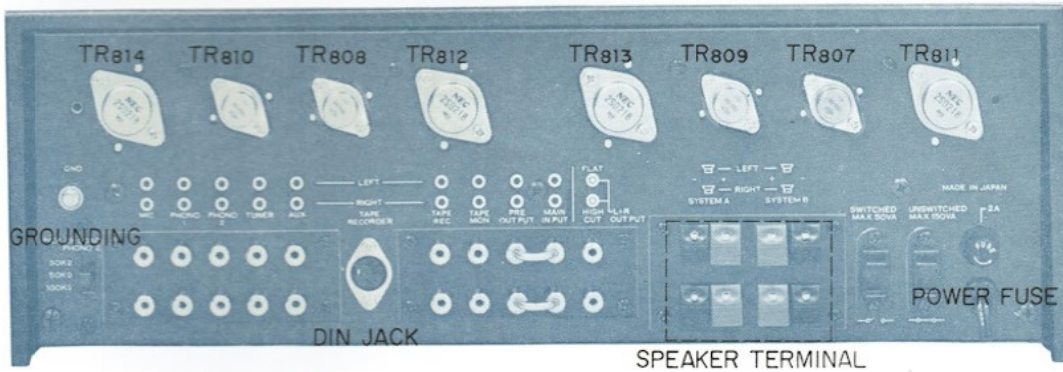

---

**sansui**

**SANSUI ELECTRIC COMPANY LIMITED**

14-1, 2-chome, Izumi, Suginami-ku, Tokyo, Japan. TEL. 323-1111

---

Printed in Japan (O9020M3)



# SANSUI AU-777A FRONT P

## VOLUME CONTROL

This control adjusts the over-all sound level of both channels. Turn it clockwise, and volume is increased.

## SPEAKERS SWITCH

This switch is used to choose between one set of speakers A and another set B, which may be installed in the same room or remotely in another part of your home. It also has a position for running all speakers at once (A+B), and another that cuts them all out for private listening with headphones (OFF).

## PROTECTOR INDICATOR

The protector circuit prevents damage to power transistors. As soon as the circuit is activated, the indicator lamp lights up to indicate trouble. In this case, immediately turn the POWER off and remedy.

## POWER INDICATOR

The POWER indicator is lit when the POWER switch is turned ON.

## POWER SWITCH

The amplifier is on when the POWER switch is moved to the ON position. On the front panel of the amplifier there are two AC outlets. The power to the left outlet is controlled by the POWER switch.

## HEADPHONES JACK

Use a headset for private listening or monitoring. The PHONES jack will accept a standard stereo phono plug.

## BALANCE CHECK SWITCH

This switch is used to check whether the sound levels from both speakers are equal. Turn the MODE switch to any MONO position; turn the BALANCE CHECK switch to ON; and adjust the BALANCE control so that the sound levels from both speakers are minimized. When not in use, make sure the switch is in NORMAL.

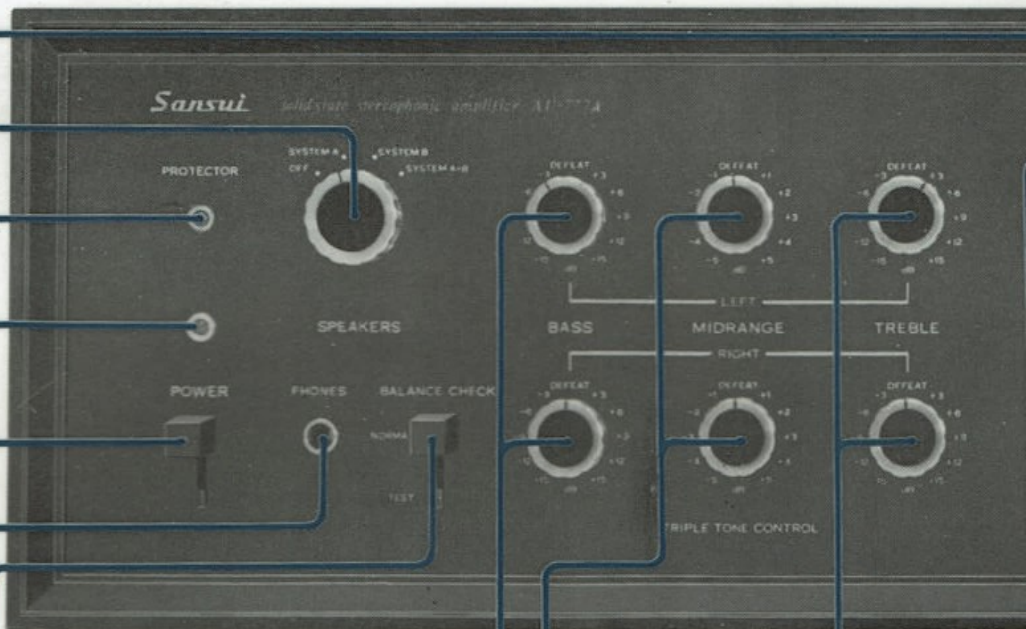

## BASS CONTROLS

The LEFT and RIGHT BASS Controls determine the amount of bass tones in the left and right channels respectively. With the BASS controls in mid-position marked DEFEAT, the bass tones will sound exactly as recorded or broadcast. If you wish to emphasize the bass, simply turn the BASS controls clockwise. The BASS controls are graduated by 3 dB per step.

## MIDRANGE CONTROLS

The LEFT and RIGHT MIDRANGE controls determine the amount of midrange tones in the left and right channels respectively. With the MIDRANGE controls in mid-position marked DEFEAT, the midrange tones will sound exactly as they appear in the program source. If you wish to emphasize the midrange, simply turn the MIDRANGE controls clockwise. The MIDRANGE controls are graduated by 1 dB per step.

## BALANCE CONTROL

This switch adjusts for equal sound levels in both left and right channels to compensate for slight imperfections in program material, variations in speaker output, and vagaries of room acoustics.

## TREBLE CONTROLS

The LEFT and RIGHT TREBLE controls determine the amount of treble tones in the left and right channels respectively. With the TREBLE controls in mid-position marked DEFEAT, the treble tones will sound exactly as they appear in the program source. If you wish to emphasize the treble, simply turn the TREBLE controls clockwise. The TREBLE controls are graduated by 3 dB per step.

## LOW FILTER

Turntable rumble and other low-frequency noises are reduced by setting the LOW FILTER switch to the ON position.

## FUNCTION CHART

(○ indicates that the given switches or knobs should be properly used.)

	SELECTOR	MODE	VOLUME	BALANCE	LOW/HIGH FILTER	BASS, MIDRANGE & TREBLE	MUTING
RECORD PLAYING	PHONO 1 or PHONO 2	STEREO or MONO	○	○	ON or OFF	○	ON or OFF
MICROPHONE	MIC	STEREO or MONO	○	○	ON or OFF	○	ON or OFF
MONITORING	SET TO THE PROGRAM	STEREO or MONO	○	○	ON or OFF	○	ON or OFF
TAPE RECORDER	PLAYBACK	STEREO or MONO	○	○	ON or OFF	○	ON or OFF
	RECORDING	SET TO THE PROGRAM	STEREO or MONO				
SOUND REPRODUCTION FROM OTHER OUTPUTS	TUNER or AUX	STEREO or MONO	○	○	ON or OFF	○	ON or OFF



# FRONT PANEL INFORMATION

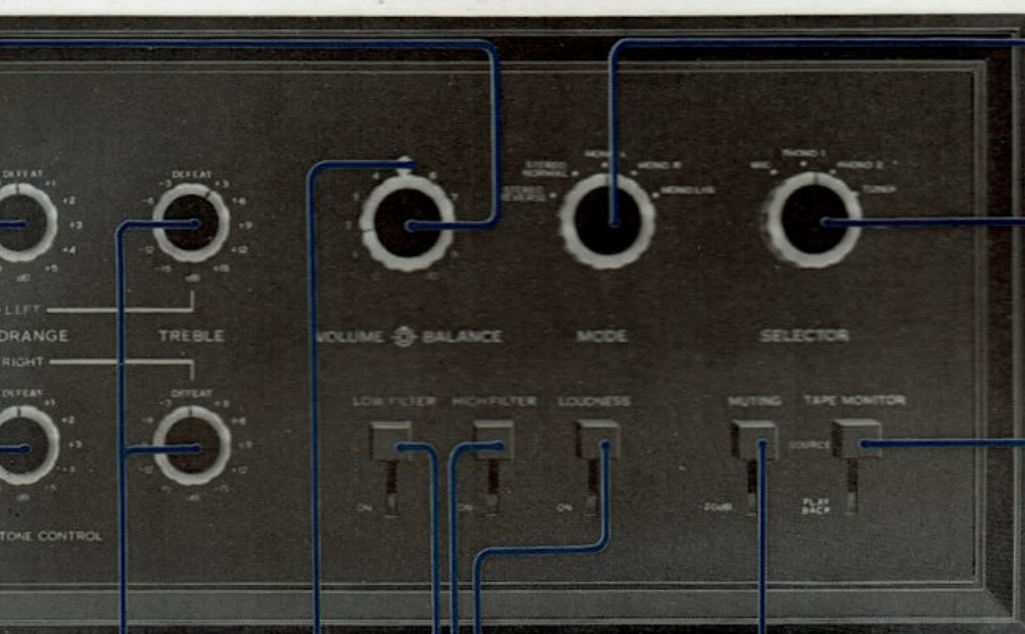

## BALANCE CONTROL

This switch adjusts for equal sound from left and right channels to compensate for any imperfections in program material, variations in speaker output, and the acoustics of room acoustics.

## TREBLE CONTROLS

LEFT and RIGHT TREBLE controls determine the amount of treble tones in the left and right channels respectively. With the TREBLE controls in mid-position and the DEFEAT switch in the DEFEAT position, the treble tones will sound as they appear in the program. If you wish to emphasize the treble, simply turn the TREBLE controls clockwise. The TREBLE controls are graduated in 1 dB per step.

## LOW FILTER

To reduce rumble and other low-frequency noises, simply set the LOW FILTER switch to the ON position.

## MUTING SWITCH

The MUTING switch attenuates music by 20 dB over the whole frequency range. It is used to eliminate interstation tuning noise, to suppress the background noise heard when changing a record, and to reduce the over-all sound level temporarily while playing a record and other program sources.

## LOUDNESS CONTROL

Whenever the volume is decreased to a low listening level, the music will seem to lose much of its bass and some of its treble. This effect is due to the sensitivity of human hearing. When the LOUDNESS switch is on, it provides the correct amount of bass and treble boost required to compensate for this change.

## HIGH FILTER

Surface noise from old or worn records, tape hiss and other high-frequency noises are reduced by setting the HIGH FILTER switch to the ON position.

## MODE SWITCH

- STEREO REVERSE**—The MODE switch in the STEREO REVERSE position connects the left input to the right speaker and the right input to the left speaker.
- STEREO NORMAL**—The MODE switch in the STEREO NORMAL position connects the left input to the left speaker and the right input to the right speaker.
- MONO L**—The MODE switch in the MONO L position connects the left input to both speakers.
- MONO R**—The MODE switch in the MONO R position connects the right input to both speakers.
- MONO L+R**—The MODE switch in the MONO L+R position connects the left input to both speakers.

## INPUT SELECTOR SWITCH

This switch selects from among the various program sources connected to the jacks on the rear panel of the amplifier.

- MIC**—Selects a microphone connected to the MIC inputs.
- PHONO 1**—Selects a record player connected to the PHONO 1 inputs on the rear panel.
- PHONO 2**—Selects a record player connected to the PHONO 2 inputs.
- TUNER**—Selects a tuner, FM adaptor or other sources connected to the TUNER inputs.
- AUX**—Selects a tuner, FM-MPX adaptor or other sources connected to the AUX inputs.

## TAPE MONITOR SWITCH

This switch enables you to compare a recorded tape with the original program. When this switch is in the PLAY BACK position, the recorded tape is heard from the speakers. Monitoring is only possible with a head tape recorder.

**Note:** When you play back through the amplifier, the TAPE MONITOR switch should be in the PLAY BACK position as well. When not in use, make sure the switch is in the SOURCE position.

(used.)

RANGE LE	MUTING	LOUDNESS	BALANCE CHECK	SPEAKERS & PHONES	TAPE MONITOR	CONNECTIONS	NOTE
	ON or OFF	ON or OFF	NORMAL	○	SOURCE	PHONO 1 or PHONO 2	Use a record player with magnetic cartridge.
	ON or OFF	ON or OFF	NORMAL	○	SOURCE	MIC	
	ON or OFF	ON or OFF	NORMAL	○	PLAY BACK	TAPE MON TAPE REC	Use a three-head tape recorder.
	ON or OFF	ON or OFF	NORMAL	○	PLAY BACK	TAPE MON	Use a tape recorder with built-in head amplifier.
					SOURCE	TAPE REC	The front panel controls and switches control the output from the TAPE REC term
	ON or OFF	ON or OFF	NORMAL	○	SOURCE	TUNER or AUX	



# SANSUI AU-777A COMPONENT

CONNECT PIN JACK

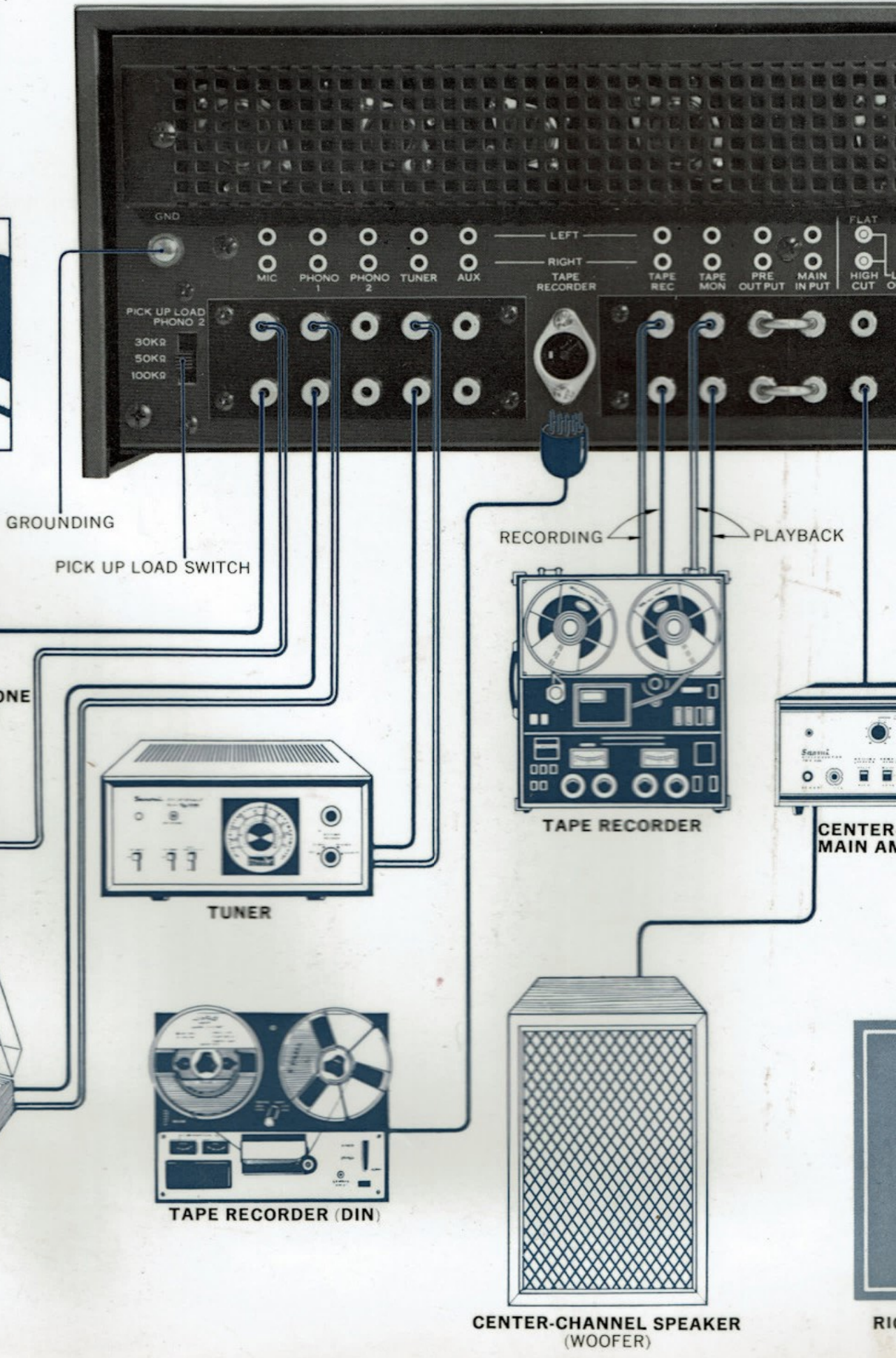
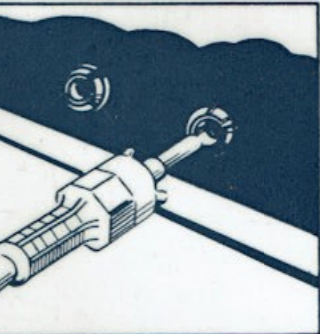

— LEFT CHANNEL  
— RIGHT CHANNEL

CENTER-CHANNEL SPEAKER (WOOFER)



# COMPONENT CONNECTIONS

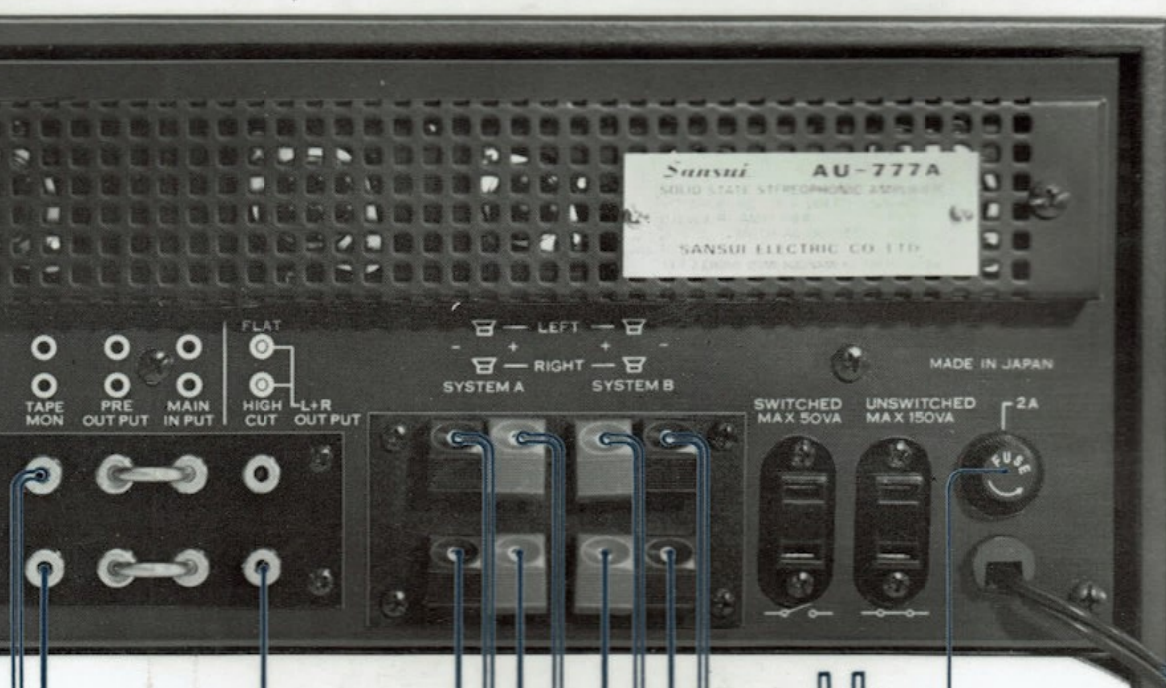

## CAUTION

Never attempt to lay this shield on the amplifier because the heat diffusion effect is largely reduced.

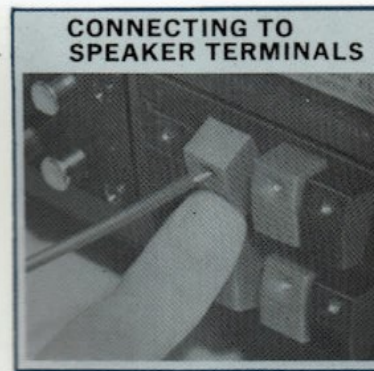

PLAYBACK

POWER FUSE

TO TAPE RECORDER OR TUNER

WALL OUTLET

CENTER-CHANNEL MAIN AMP

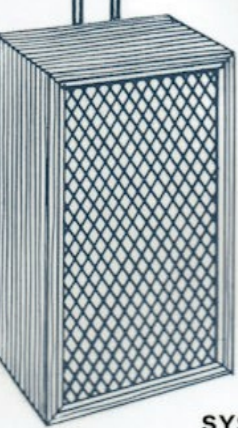

SYSTEM - B

LEFT SPEAKER

RIGHT SPEAKER

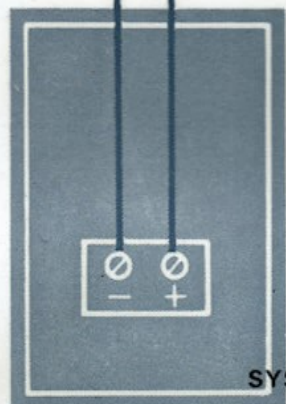

SYSTEM - A

RIGHT SPEAKER

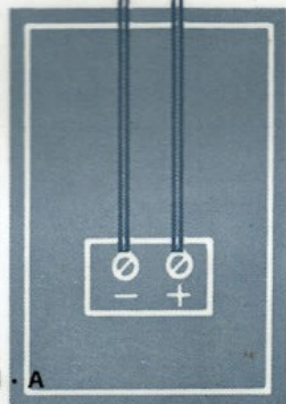

LEFT SPEAKER



SANSUI ELECTRIC COMPANY LIMITED

Head Office: 14-1, 2-chome, Izumi, Suginami-ku, Tokyo, Japan. TEL. 323-

Printed in Japan (0902)



# SANSUI AU-777A SC

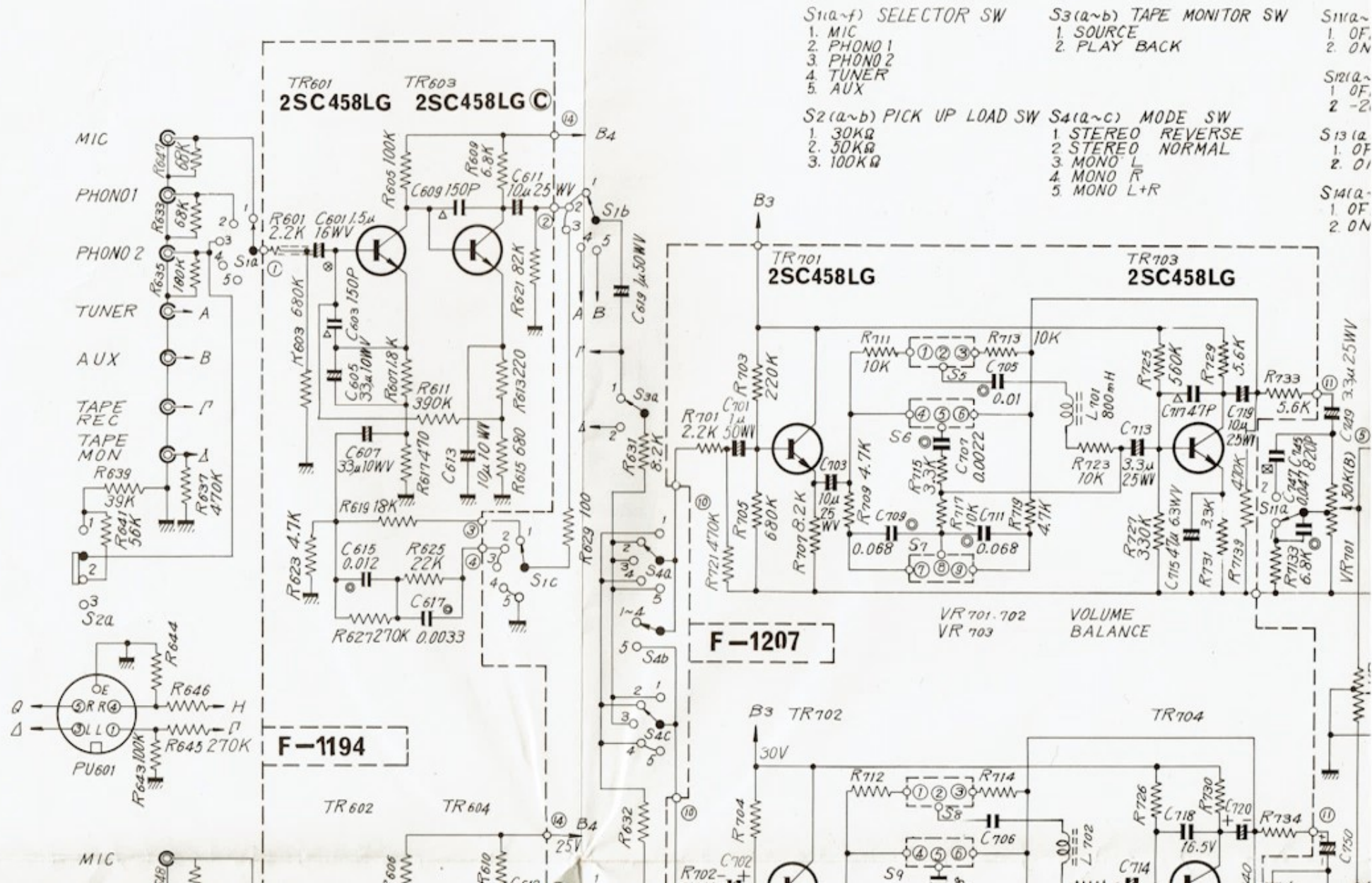

S1(a-f) SELECTOR SW

1. MIC
2. PHONO 1
3. PHONO 2
4. TUNER
5. AUX

S3(a-b) TAPE MONITOR SW

1. SOURCE
2. PLAY BACK

S1(a~)

1. OF
2. ON

S2(a~)

1. OF
- 2 - 2

S2(a-b) PICK UP LOAD SW

1. 30KΩ
2. 50KΩ
3. 100KΩ

S4(a~c) MODE SW

1. STEREO REVERSE
2. STEREO NORMAL
3. MONO L
4. MONO R
5. MONO L+R

S13(a)

1. OF
2. ON

S14(a)

1. OF
2. ON

F-1207

F-1194

VR 701.702  
VR 703  
VOLUME  
BALANCE



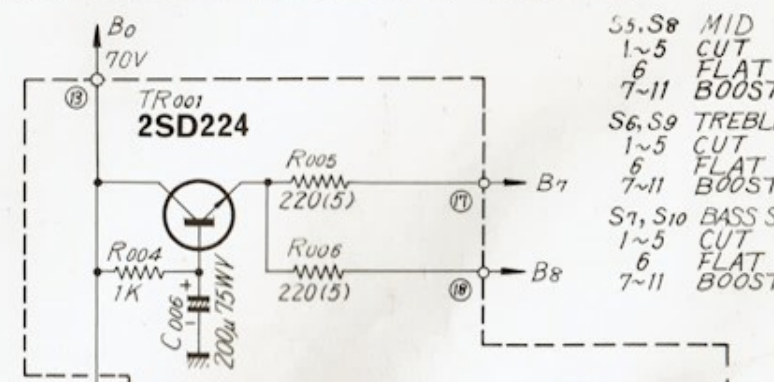
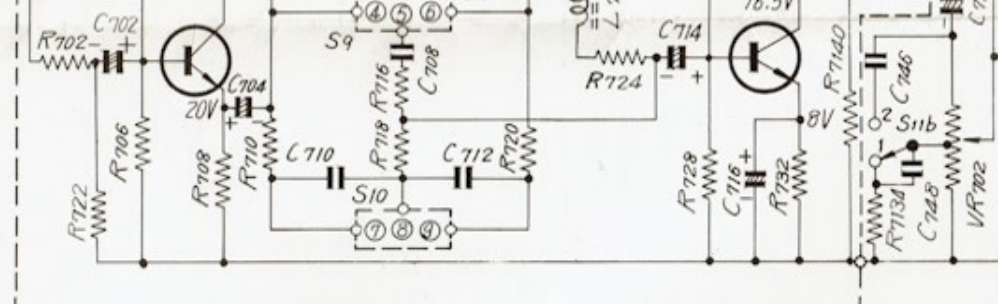
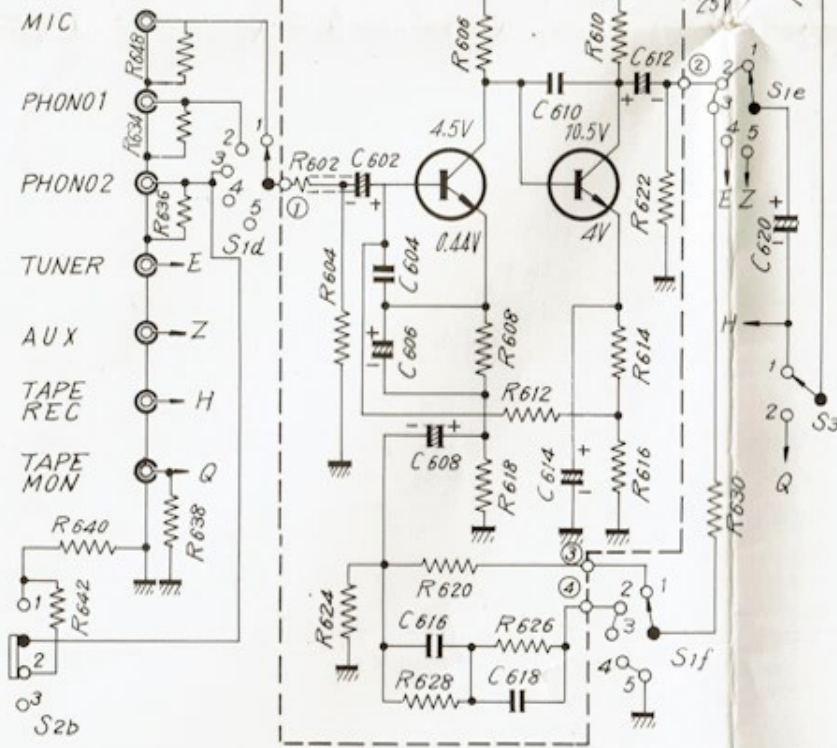

- 55, S8 MID
- 1-5 CUT
- 6 FLAT
- 7-11 BOOST
- S6, S9 TREBLE
- 1-5 CUT
- 6 FLAT
- 7-11 BOOST
- S7, S10 BASS
- 1-5 CUT
- 6 FLAT
- 7-11 BOOST

- SYMBOL
- OIL
  - MICA
  - △ CERAMIC
  - MYLAR
  - ⊗ TANTAL
  - ⊠ POLYSTYLENE

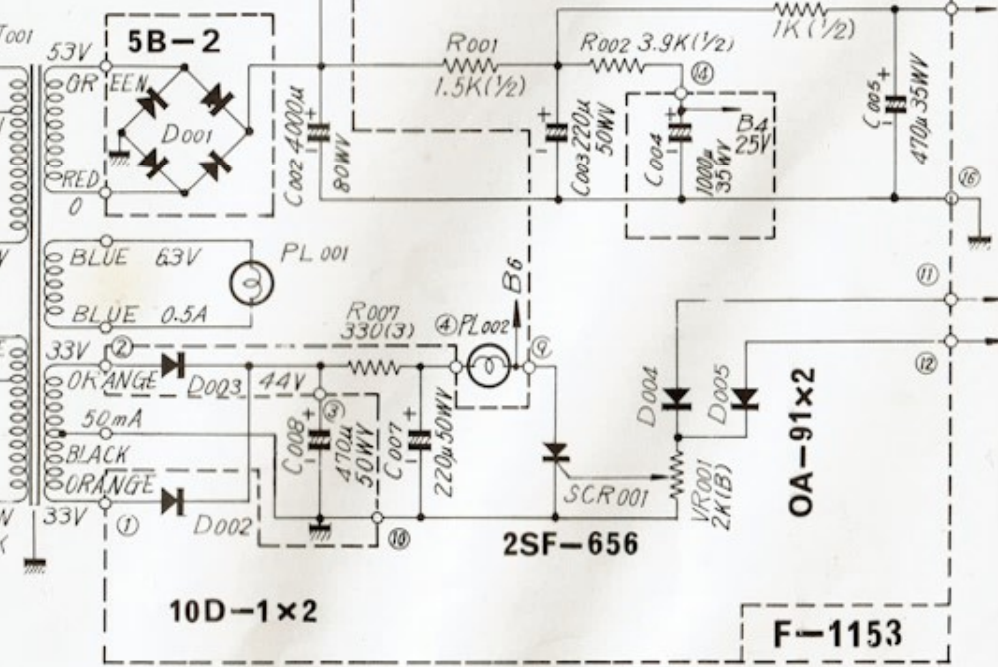
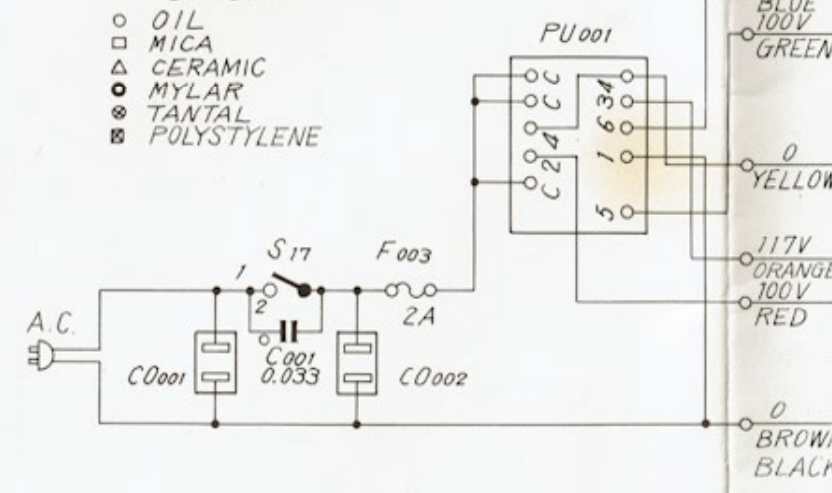

\* All rights reserve specifications subject to change without notice.



# SCHEMATIC DIAGRAM

- LOUDNESS SW S15 (a~b) BALANCE CHECK SW  
 1 NORMAL  
 2 TEST
- MUTING SW S18 (a~d) SPEAKER SW  
 1 SPEAKER OFF  
 2 SYSTEM A  
 3 SYSTEM B  
 4 SYSTEM A+B
- LOW FILTER SW S17 POWER SW  
 1 OFF  
 2 ON
- HIGH FILTER SW

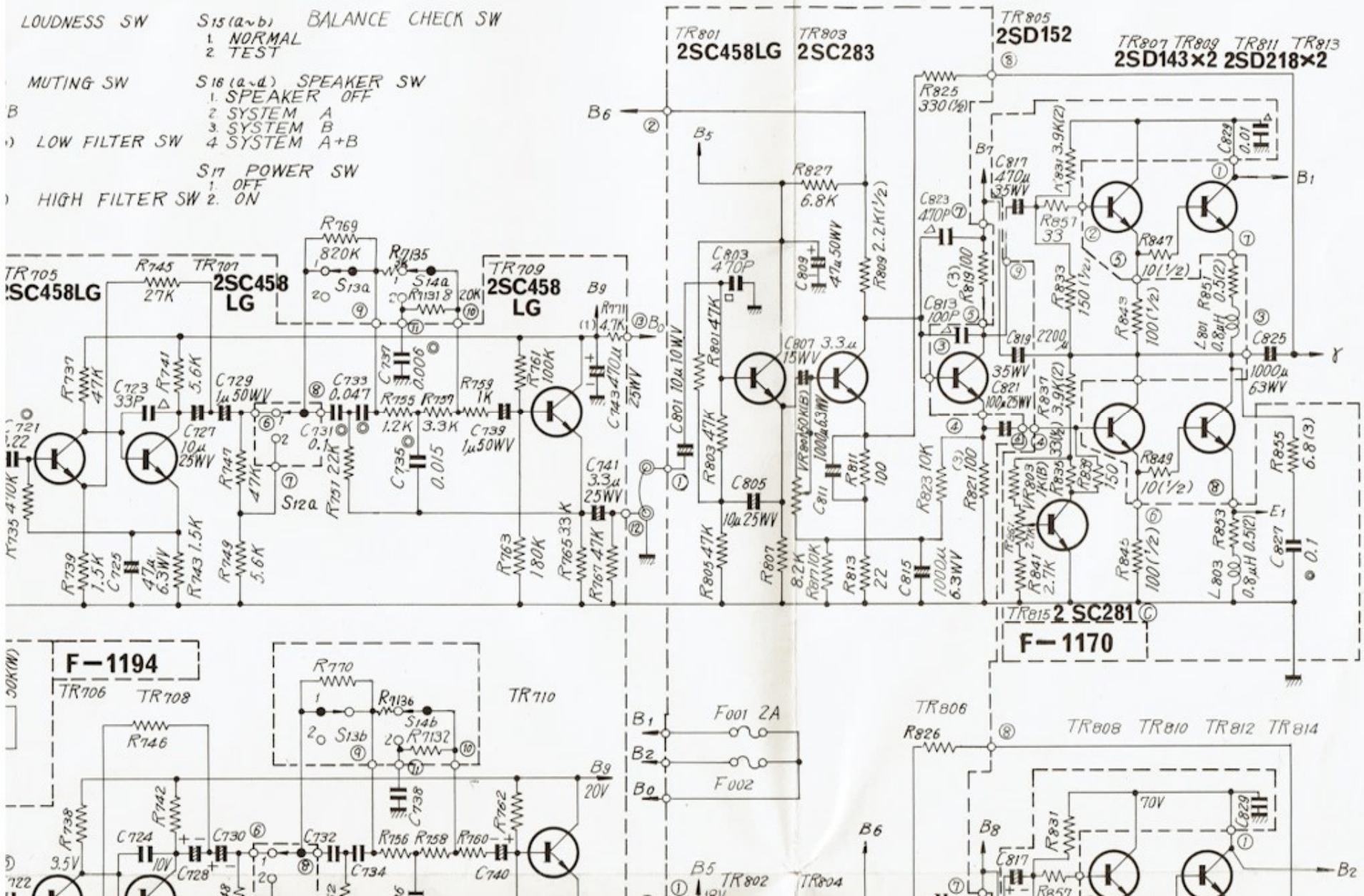

F-1194

TR815 2SC281  
F-1170

TR808 TR810 TR812 TR814

TR801 2SC458LG  
TR803 2SC283

TR805 2SD152  
TR807 TR809 TR811 TR813  
2SD143x2 2SD218x2



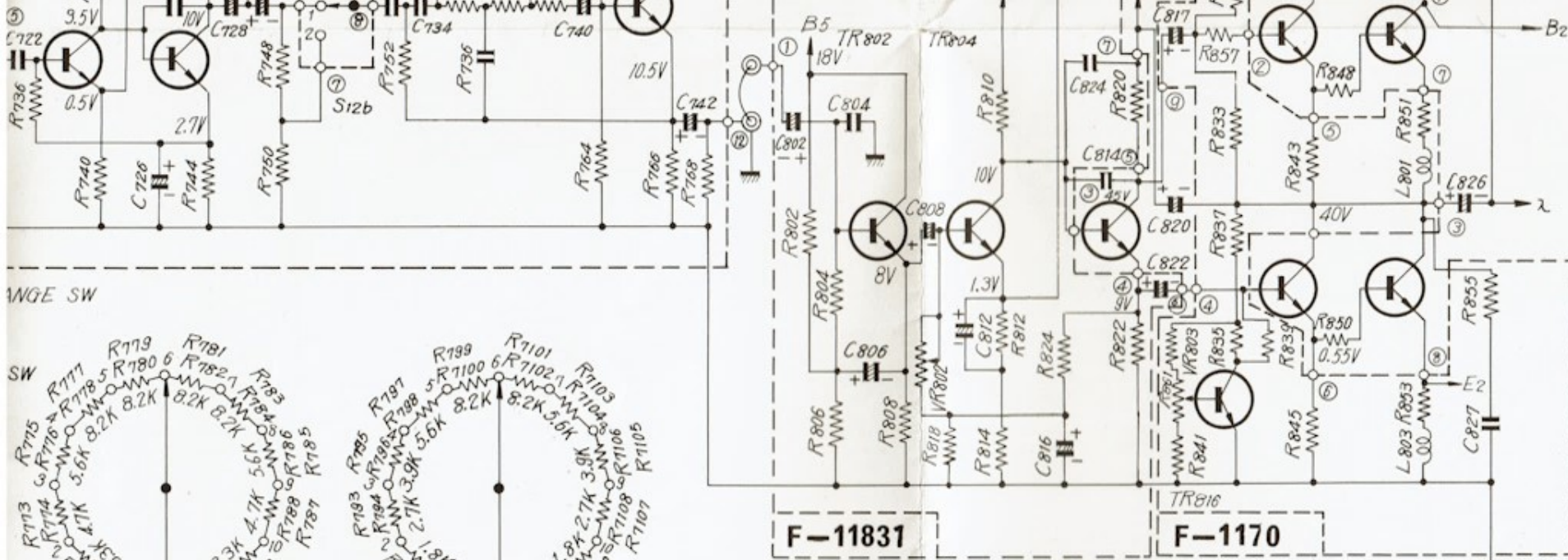

ANGE SW

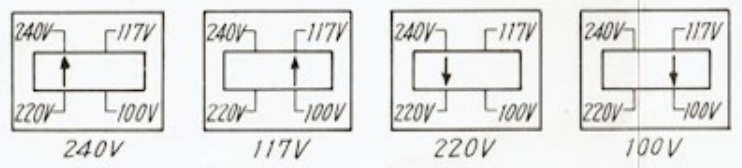
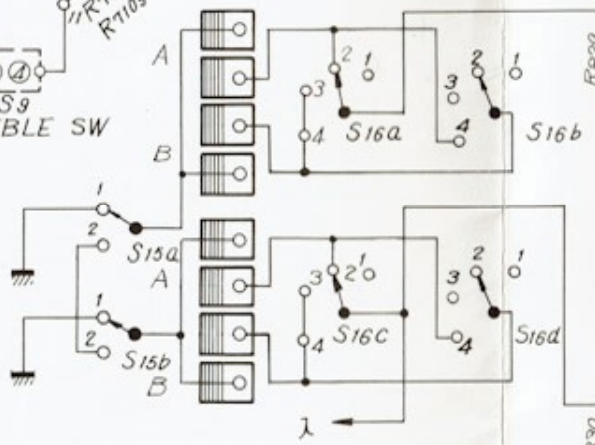
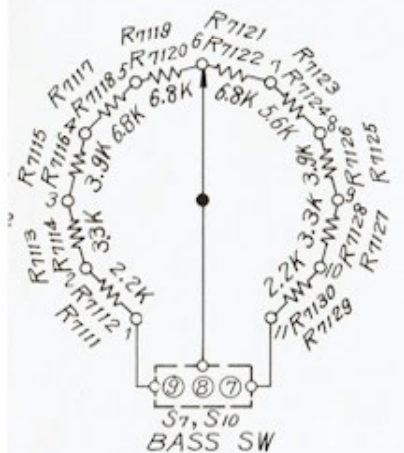
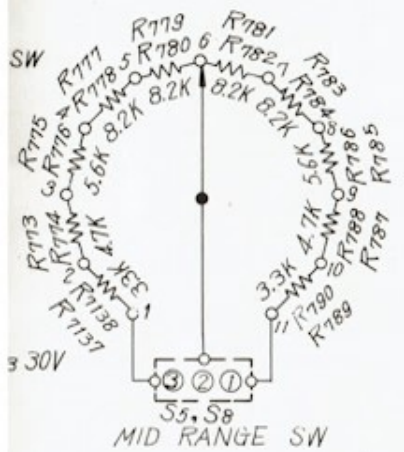

F-1183

F-1170

F-1153