

The home of the turntable

THE VINYL **ENGINE**®

For more turntable manuals and setup information
please visit www.vinylengine.com

KENWOOD

KD-770D

QUARTZ PLL DIRECT DRIVE TURNTABLE

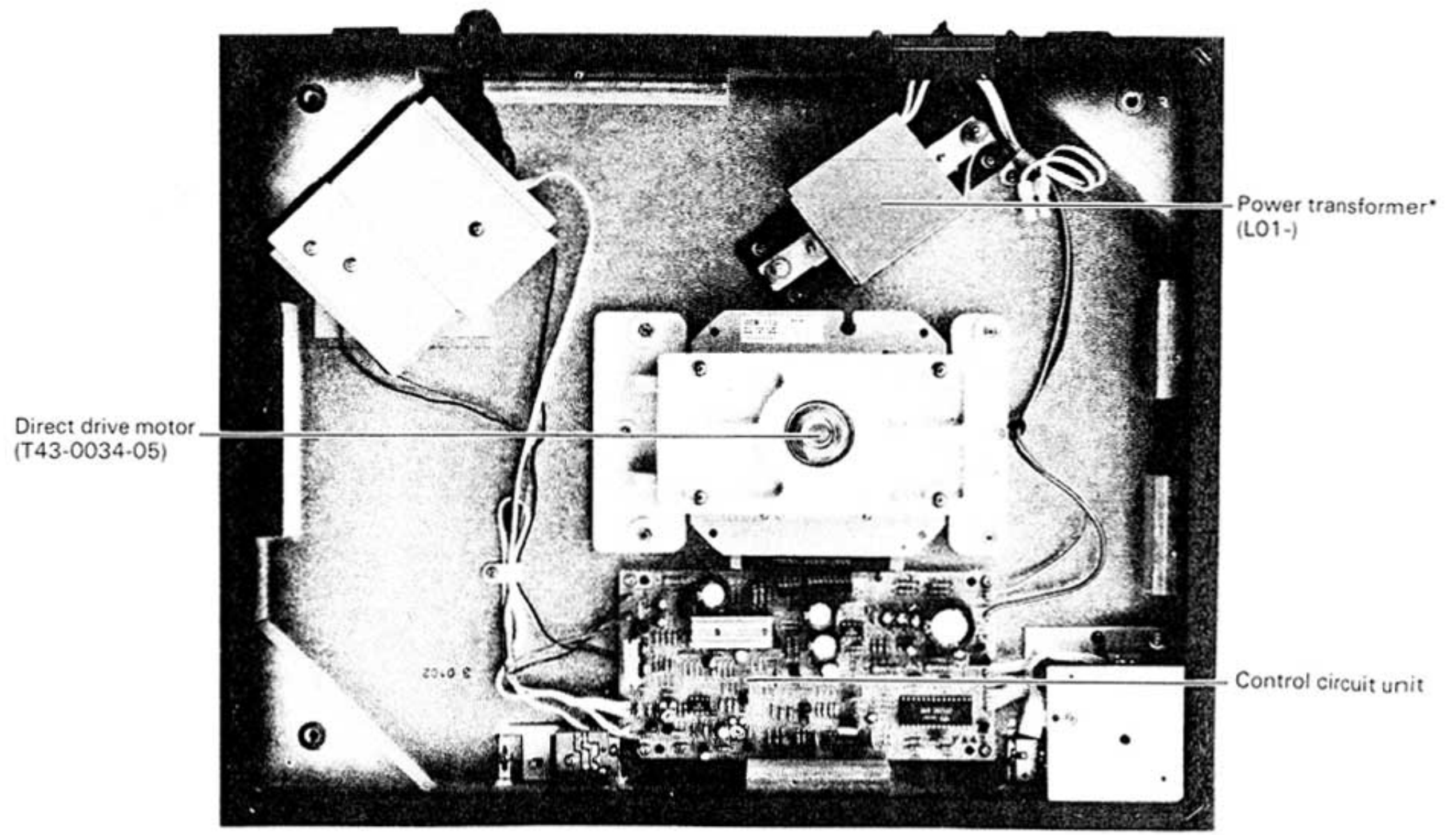
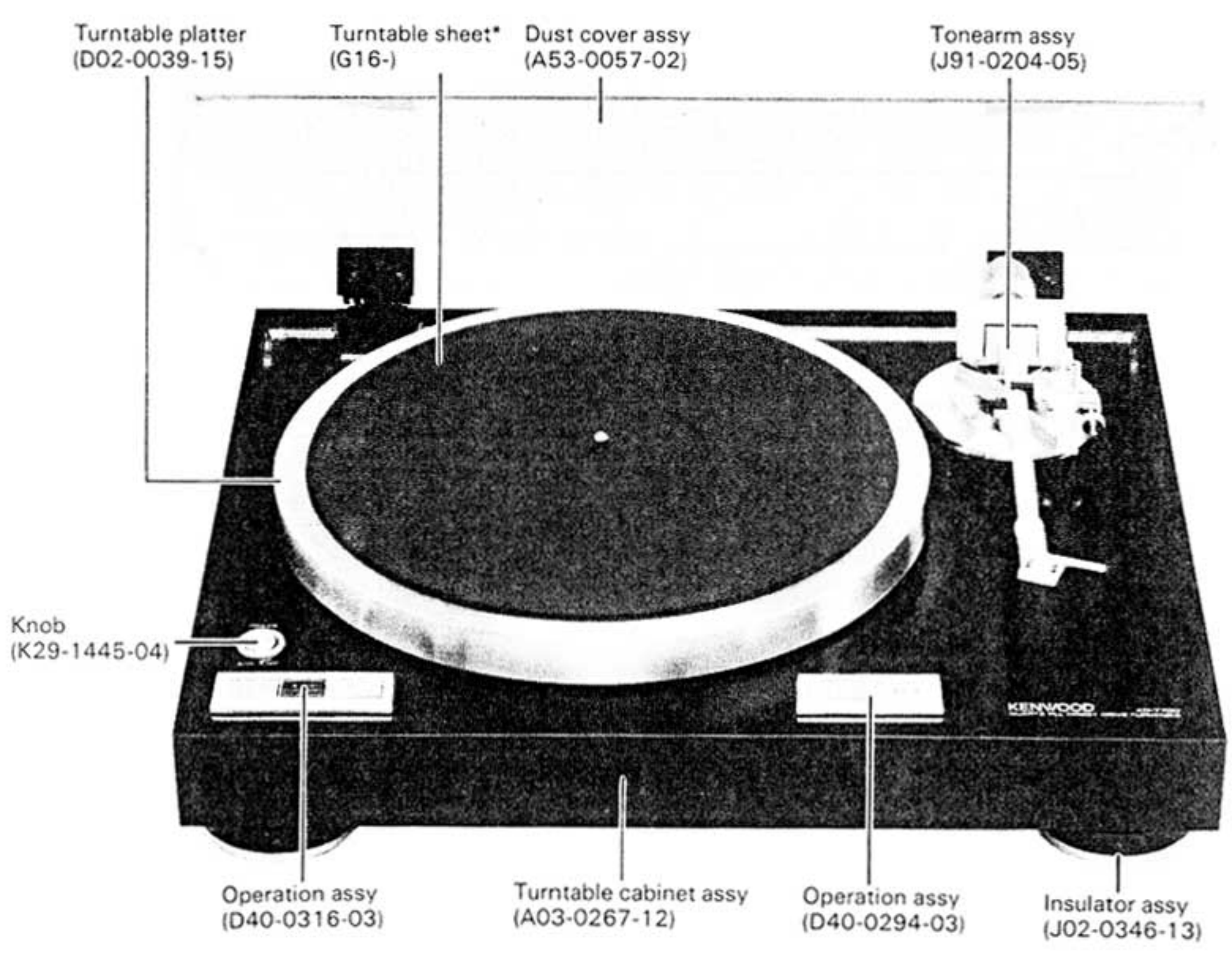

Caution: In EXPLODED VIEW Parts with the exploded numbers larger than 700 are not supplied. Refer to Parts list on Page 9.

BLOCK DIAGRAM

BLOCK DIAGRAM

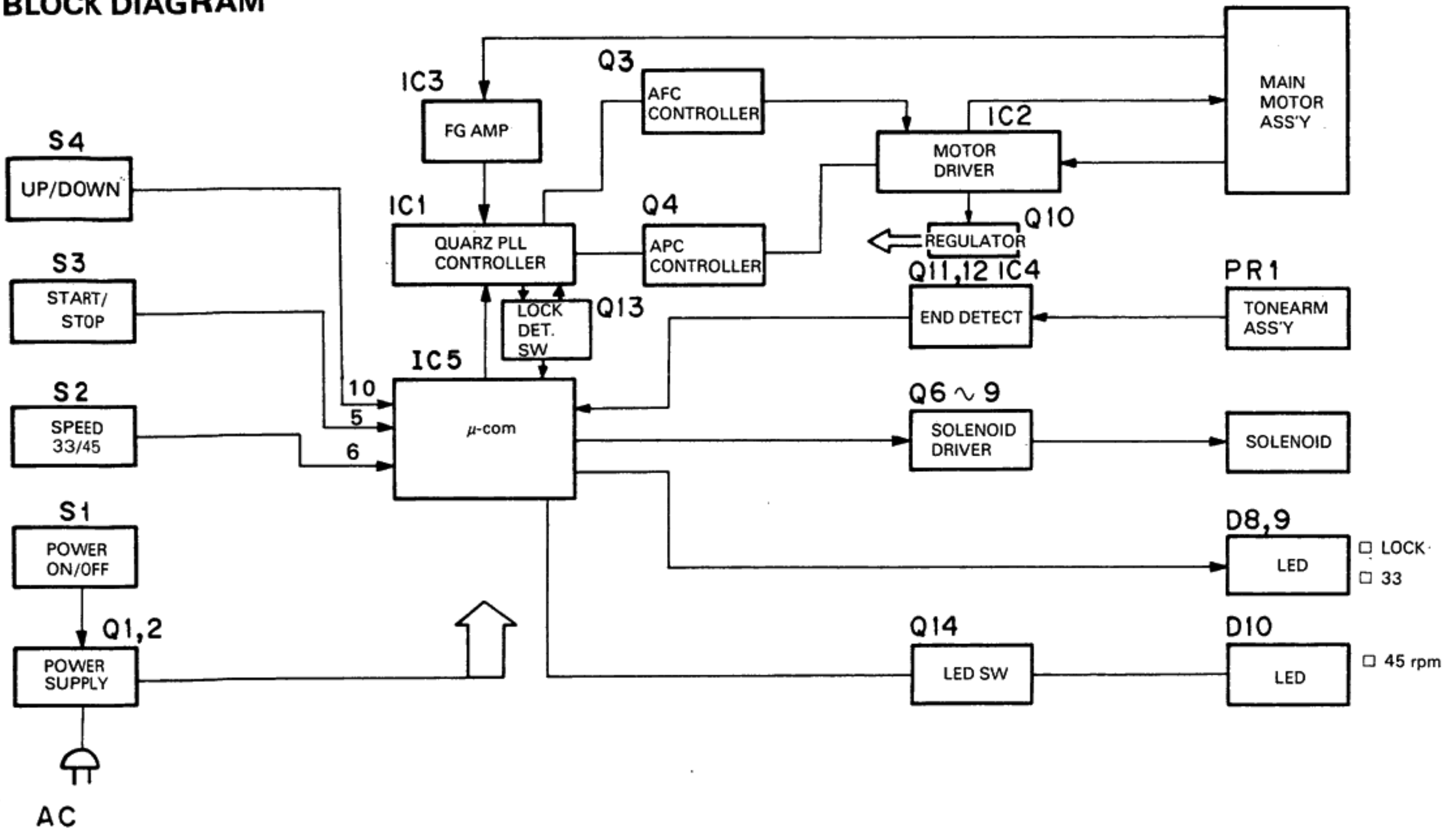

LOGIC CONTROL

a. Input switches are described below.

SW.	FUNCTIONS
START/STOP	<ul style="list-style-type: none"> ○ Initialized to STOP state when power is turned on. ○ Switches between START and STOP state at every one push. ○ 4 seconds after END detection, the switch returns to STOP state (auto stop function). ○ When STOP button is pressed, braking operation is executed till the turntable rotational speed becomes below prescribed speed.
33/45	<ul style="list-style-type: none"> ○ Initialized to 33 1/3 r.p.m. when power is turned on. ○ Switches between 33 1/3 r.p.m. and 45 mode at every one push.
UP/DOWN	<ul style="list-style-type: none"> ○ Initialized to UP state when power is turned on. ○ Switches between UP and DOWN state at every one push. ○ When END detection is operated, the tonearm returns to UP state. (auto up function) * When power switch or AC line is turned off, the tonearm returns to UP state.
	Function of each input switch is independent.

CIRCUIT DESCRIPTION

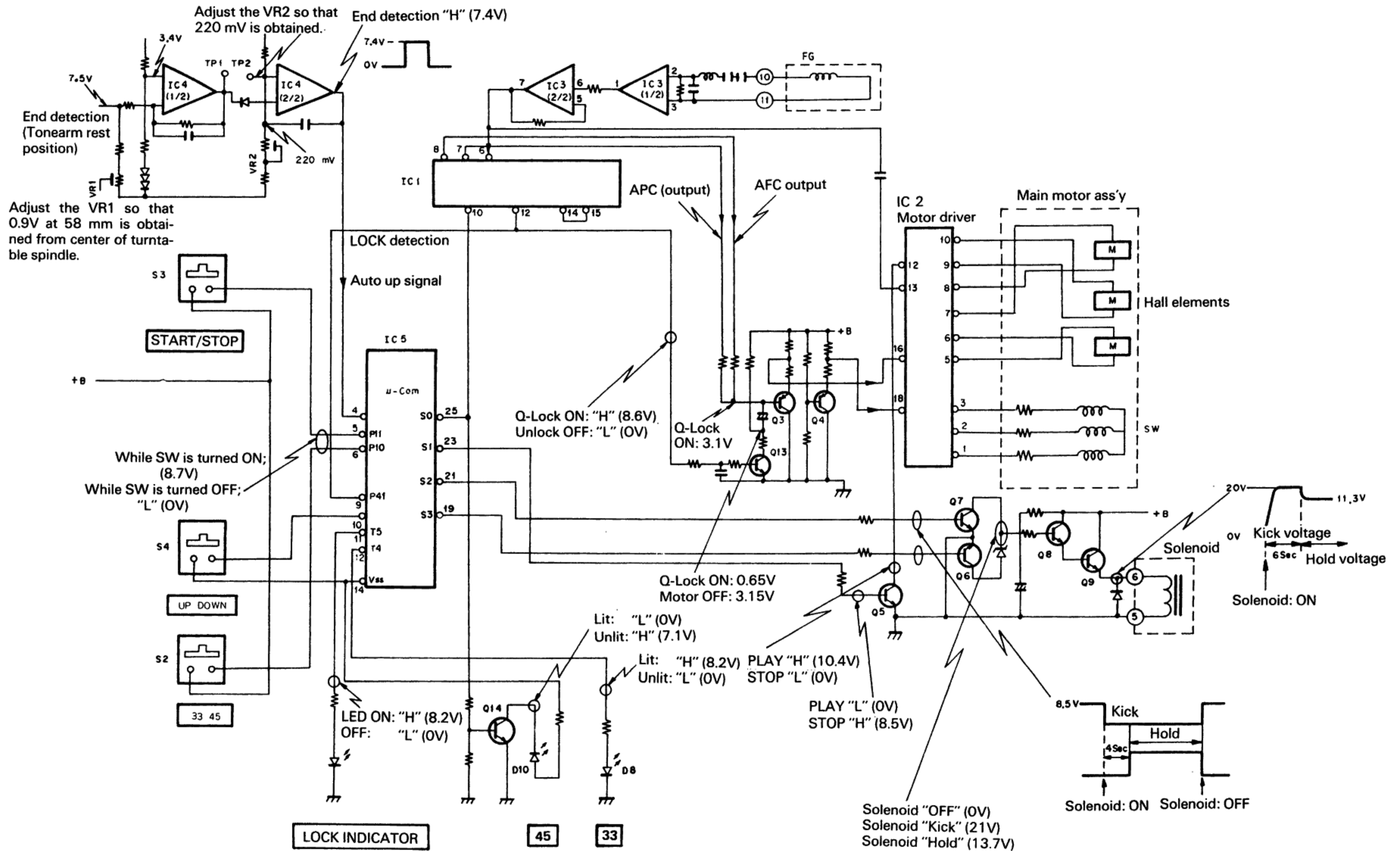

CIRCUIT DESCRIPTION

Port description of μ PD 7520C-028

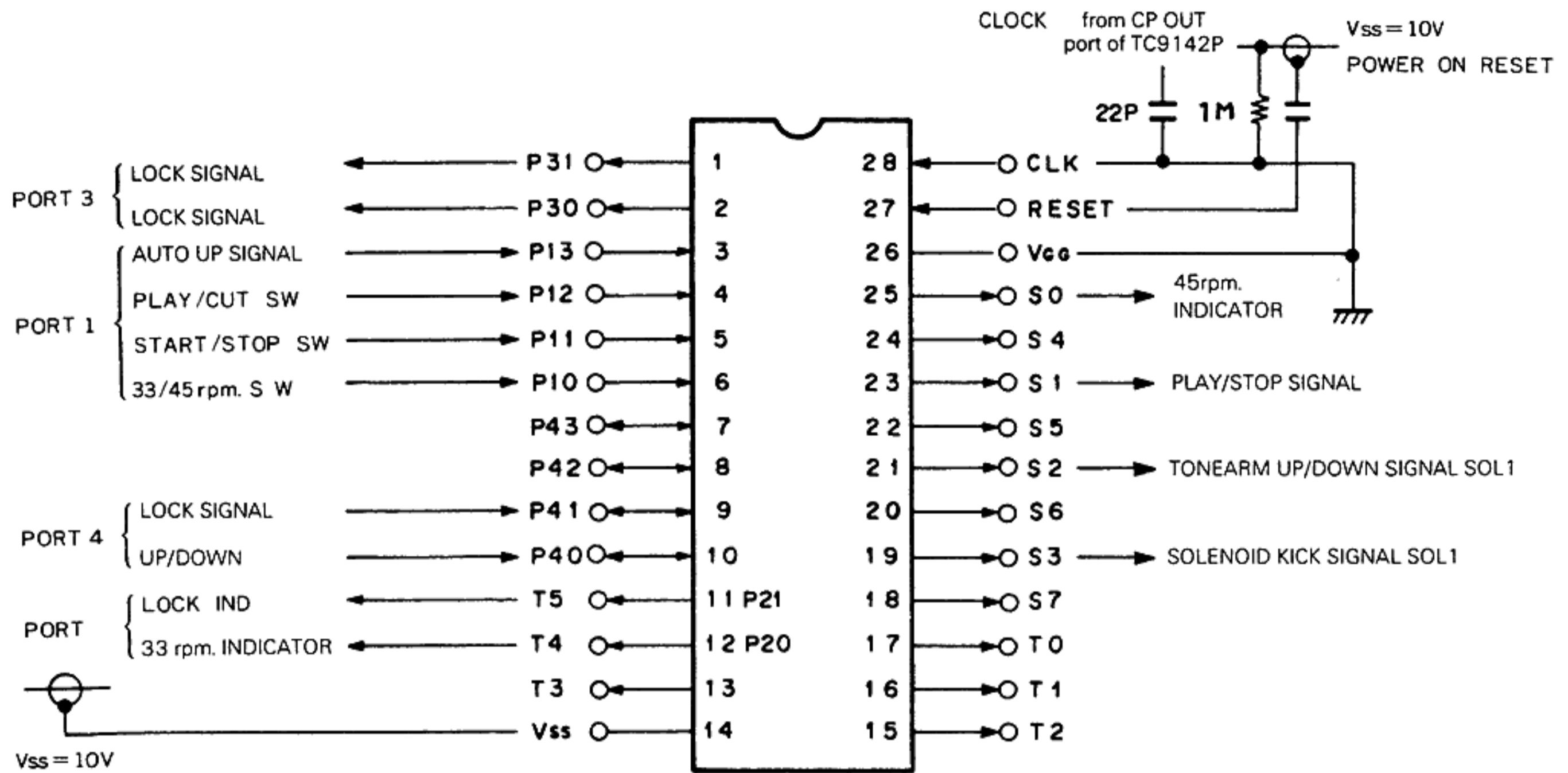

Note: Port 30 and 31 (Port 3: Lock signal output) are not used in KD-770D.

μ PD7520C-028 Function description

Operation starting from the time the power switch is turned on is shown below in the following.

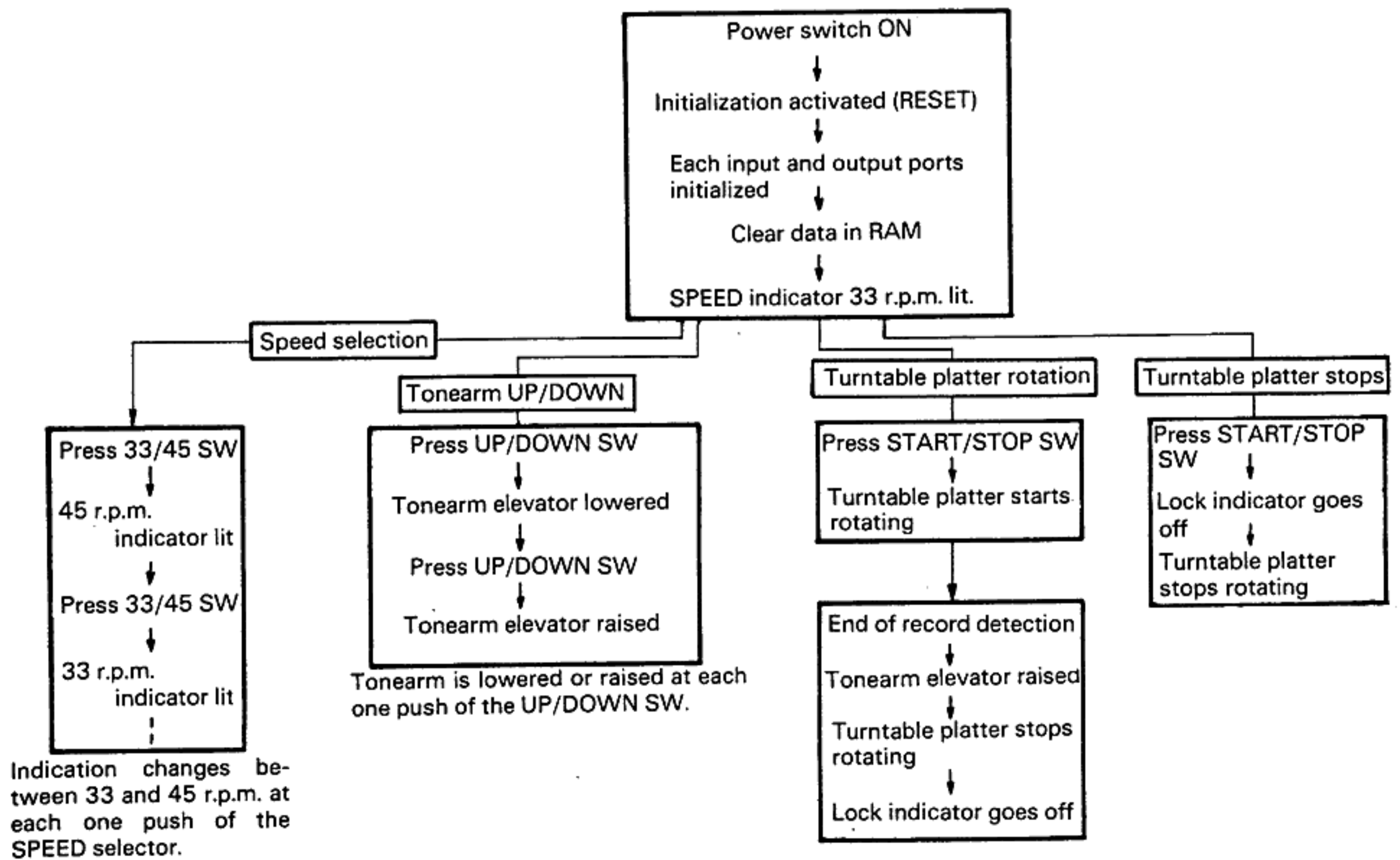

CIRCUIT DESCRIPTION

Condition of each μ PD7520C-028 ports

- (1) Initialization (Power ON)
- (2) Speed selection (33/45 rpm)
- (3) Turntable platter starts rotating (START)
- (4) Tonearm auto up
- (5) Turntable platter stops rotating (STOP)

The above mentioned (1) ~ (5) are placed in the order of the functions described in " μ PD7520C-028 Function description".
The conditions shown in the table below are also in that order so that functions can be confirmed while checking the IC's ports.

		INPUT PORT					OUTPUT PORT						
PORT NO.		P 10	P 11	P 12	P 13	P 40	P 41	T 4	T 5	S 0	S 1	S 2	S 3
PIN NO.		6	5	4	3	10	9	12	11	25	23	21	19
PORT NAME		33/45 SW	START STOP SW	AUTO UP Signal	Not used	UP DOWN SW	LOCK Signal	33rpm LED	LOCK LED	45rpm LED	START STOP Signal	UP DOWN Signal	Kick Signal
(1)	Power ON RESET	[Timing diagram showing initial state]											
(2)	33/45 SW ON (45) ↓ 33/45 SW ON (33)	[Timing diagram showing speed selection]											
(3)	START/STOP SW ON	[Timing diagram showing start/stop]											
(4)	Auto up signal IN START/STOP SW ON	[Timing diagram showing auto up]											
(5)	START/STOP SW ON	[Timing diagram showing stop]											

I/O port timing diagram

(Note) This diagram shows the timing for operations (1) to (5) described on page 4.

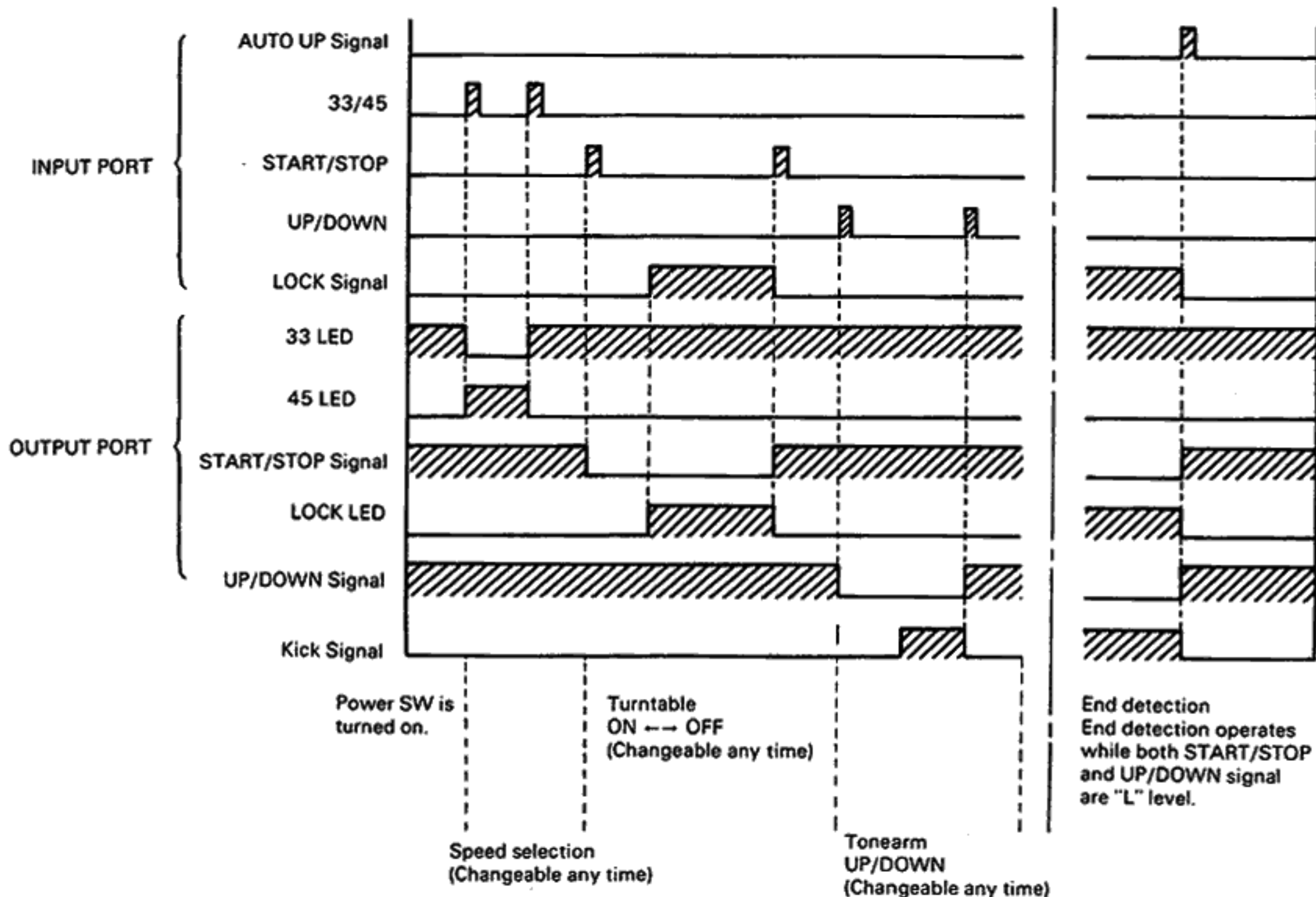

PC BOARD/ADJUSTMENT/REGLAGES/ABGLEICH

CONTROL PCB (X29-1510-01) Component side view

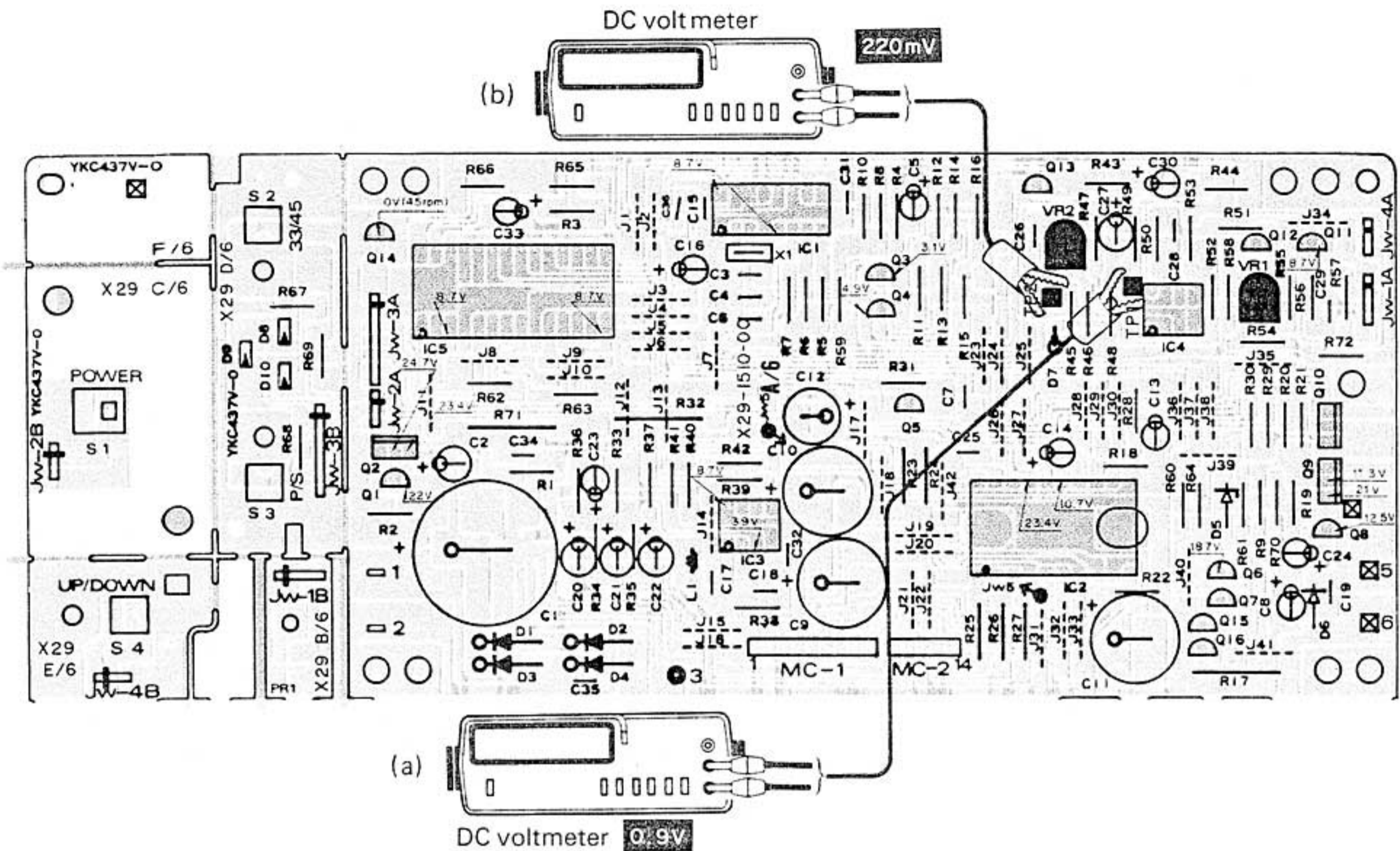

Refer to the schematic diagram for the values of resistors and capacitors. The PC board drawing is viewing from the side easy to check.

ADJUSTMENT

No.	ITEM	INPUT SETTINGS	OUTPUT SETTINGS	TURNTABLE SETTING	ALIGNMENT POINTS	ALIGN FOR	FIG.
1	END DETECT STARTING POSITION	-	Connect a DC voltmeter to TP1 (Pin 7 of IC4)	Set the stylus tip so that 57.5mm is obtained from the center of the turntable spindle.	VR1	0.9V	(a)
2	THRESHOLD VOLTAGE	-	Connect a DC voltmeter to TP2 (Pin 2 of IC4)	-	VR2	220mV	(b)

REGLAGES

N°	ITEM	REGLAGE DE L'ENTREE	REGLAGE DE LA SORTIE	REGLAGE DE TOURNE-DISQUE	POINTS L'ALIGNMENT	ALIGNER POUR	FIG.
1	POSITION DE DEPART LA TERMINASION DE DETECTEUR	-	Connecteur un voltmètre CC à TP1 (Fiche 7 de IC4)	Régler la crête de aiguille de façon de 57,5mm soit obtenir de centre de plateau à disques.	VR1	0,9V	(a)
2	TENTION DE SEUIL	-	Connecteur un voltmètre CC à TP2 (Fiche 2 de IC4)	-	VR2	220mV	(b)

ABGLEICH

NR.	GEGENSTAND	EINGANGS-EINSTELLUNG	AUSGANGS-EINSTELLUNG	PLATTEN SPIELER-EINSTELLUNG	ABGLEICH PUNKTE	ABGLEICHEN FÜR	ABB.
1	ENDE DETEKTS ANFANGS-STELLUNG	-	Einen Gleichspannungsmesser zu TP1 (Stift 7 von IC4) anschließen.	Der spitze von Tonabnehmer so einstellen, daß ein 57,5mm aus der mitte des Plattentellers erhält wird.	VR1	0,9V	(a)
2	SCHWELLEN-SPANNUNG	-	Einen Gleichspannungsmesser zu TP2 (Stift 2 von IC4) anschließen.	-	VR2	220mV	(b)

QUARTZ PLL DIRECT DRIVE TURNTABLE

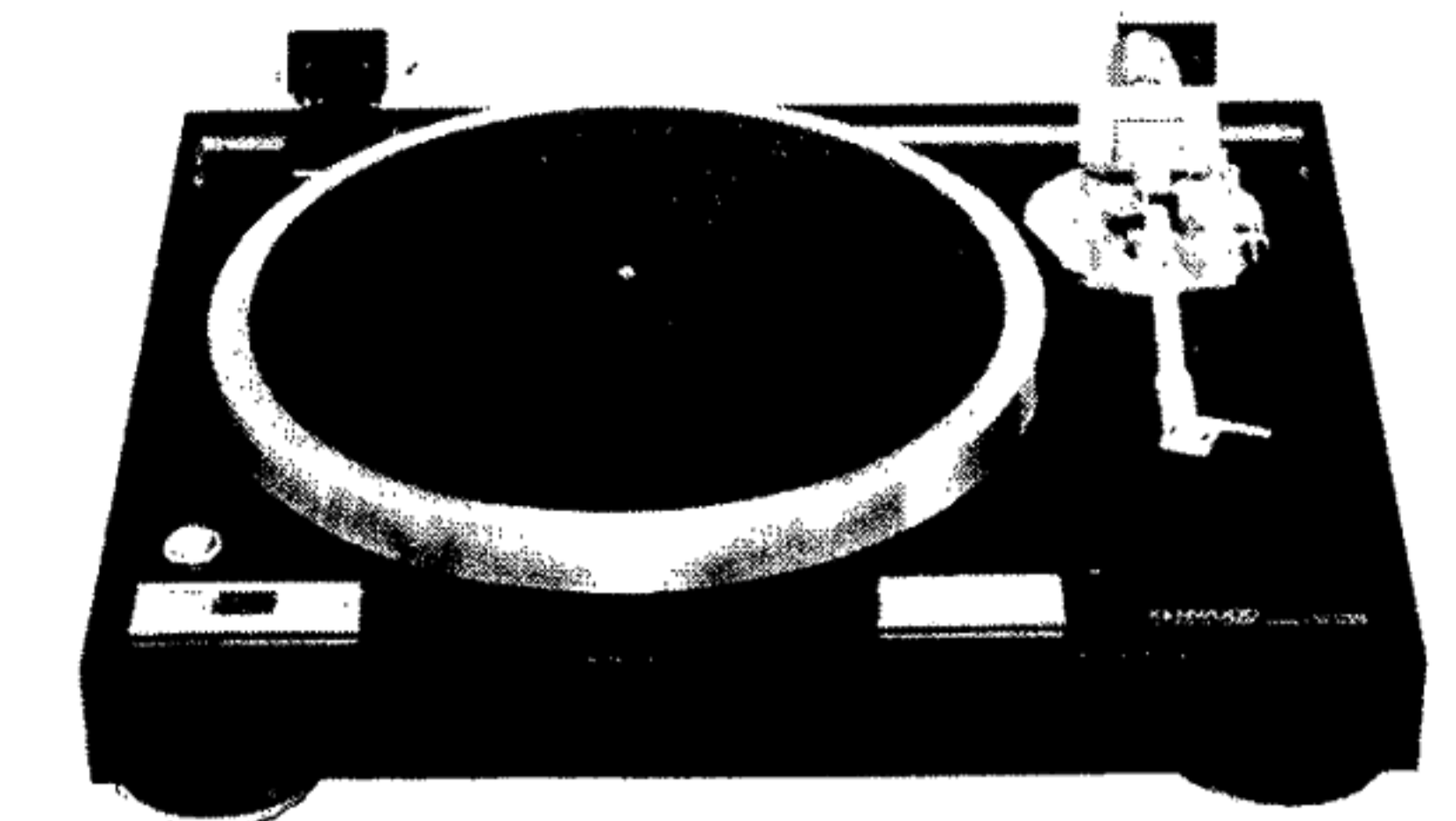
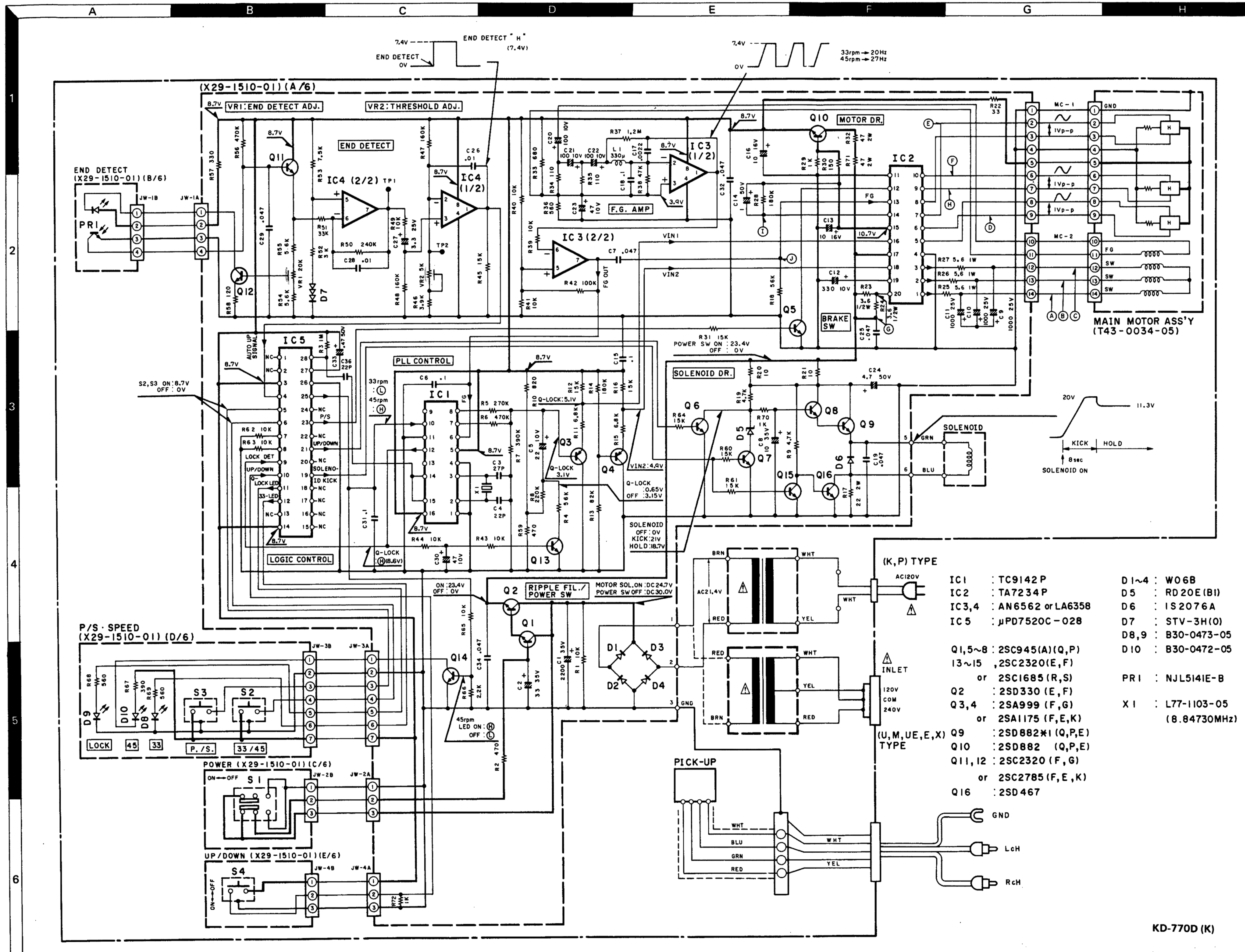

Specifications

Motor and turntable

- Drive System..... Direct-drive system
- Motor..... Quartz PLL core & slotless DC servo motor
- Turntable Platter..... 33 cm (13") diameter
Aluminum alloy, Die-cast
- Speeds..... 2 speeds, 33-1/3 and 45 rpm
- Wow & Flutter..... Less than 0.02% (WRMS)
Less than 0.03% (DIN)
- Rumble..... DIN weighted better than -80 dB
DIN unweighted better than -55 dB

Tonearm

- Type..... Static-balance type, Straight tubular arm
- Effective Tonearm Length..... 245 mm (9-5/8")
- Overhang..... 15 mm (9/16")
- Tracking Error..... + 1.8' to -1.0'
- Tracking Force Range..... 0 to 3 grams (0.1 g Step)
- Usable Cartridge Weight..... 2.0 to 12 grams (with supplied head-shell)

Miscellaneous

- Power Requirements.. AC 120 V, 60 HZ: U.S.A. and Canada Models,
AC110 - 120/220 - 240 V, 50/60 Hz (Switchable): Other countries
- Power Consumption.. 22 watts
- Dimensions..... W 490 mm (19-5/16")
H 162 mm (6-3/8")
D 410 mm (16-5/32")
- Weight..... 11.7 kg (25.7 lb)
- Supplied Accessory.. 45 rpm adaptor,
Hexagonal bar wrench

Kenwood follows a policy of continuous advancements in development. For this reason specifications may be changed without notice.

Kenwood poursuit une politique de progrès constants en ce qui concerne le développement. Pour cette raison, les spécifications sont sujettes à modifications sans préavis.

Kenwood strebt ständige Verbesserungen in der Entwicklung an. Daher bleiben Änderungen der technischen Daten jederzeit vorbehalten.

DC voltages are as measured with a high impedance voltmeter at 33-1/3 r.p.m. mode. Values may vary slightly due to variations between individual instruments or/and units.

- | | | | |
|--------|--------------------|------|---------------|
| IC1 | : TC9142 P | D1~4 | : W06B |
| IC2 | : TA7234 P | D5 | : RD20E(BI) |
| IC3,4 | : AN6562 or LA6358 | D6 | : 1S2076A |
| IC5 | : μPD7520C-02B | D7 | : STV-3H(O) |
| Q1,5~8 | : 2SC945(A)(Q,P) | D8,9 | : B30-0473-05 |
| 13~15 | : 2SC2320(E,F) | D10 | : B30-0472-05 |
| or | 2SC1685(R,S) | PRI | : NJL514E-B |
| Q2 | : 2SD330 (E,F) | X1 | : L77-1103-05 |
| Q3,4 | : 2SA999 (F,G) | | (8.84730MHz) |
| or | 2SA1175 (F,E,K) | | |
| Q9 | : 2SD882*(I,Q,P,E) | | |
| Q10 | : 2SD882 (Q,P,E) | | |
| Q11,12 | : 2SC2320 (F,G) | | |
| or | 2SC2785 (F,E,K) | | |
| Q16 | : 2SD467 | | |

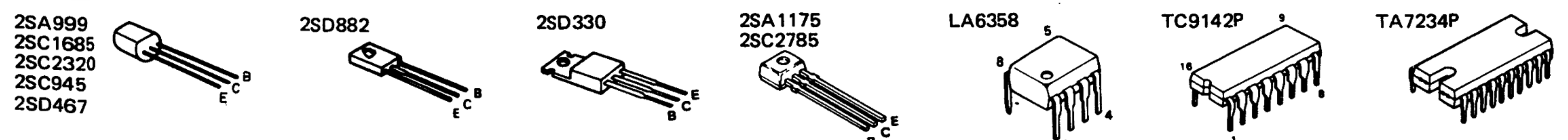

KD-770D (K)

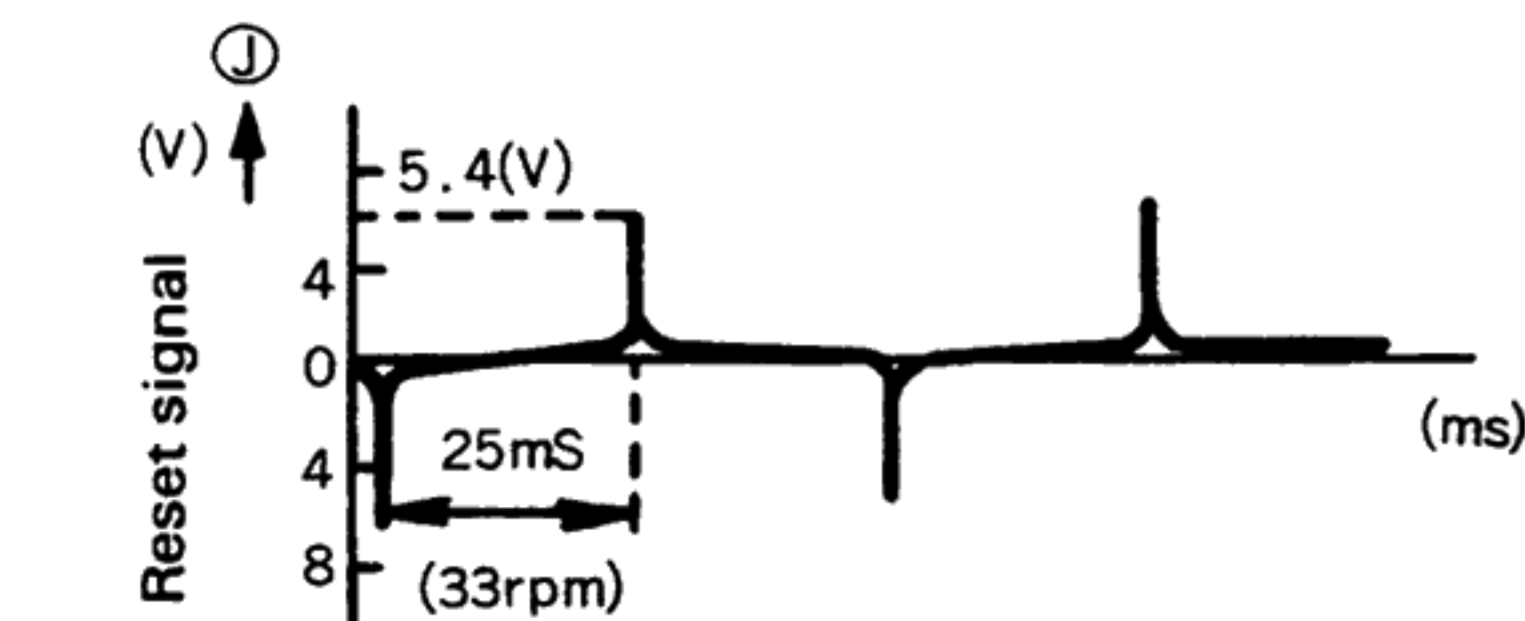
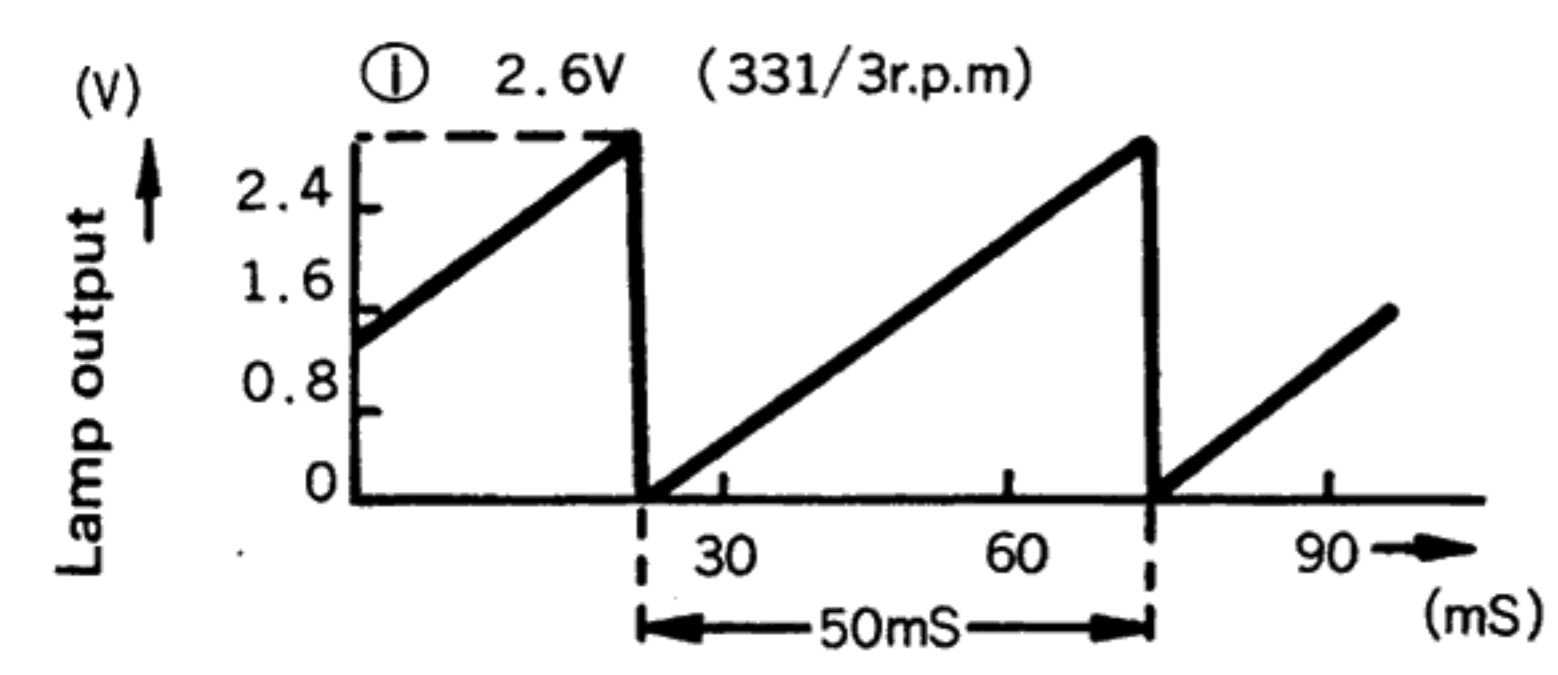
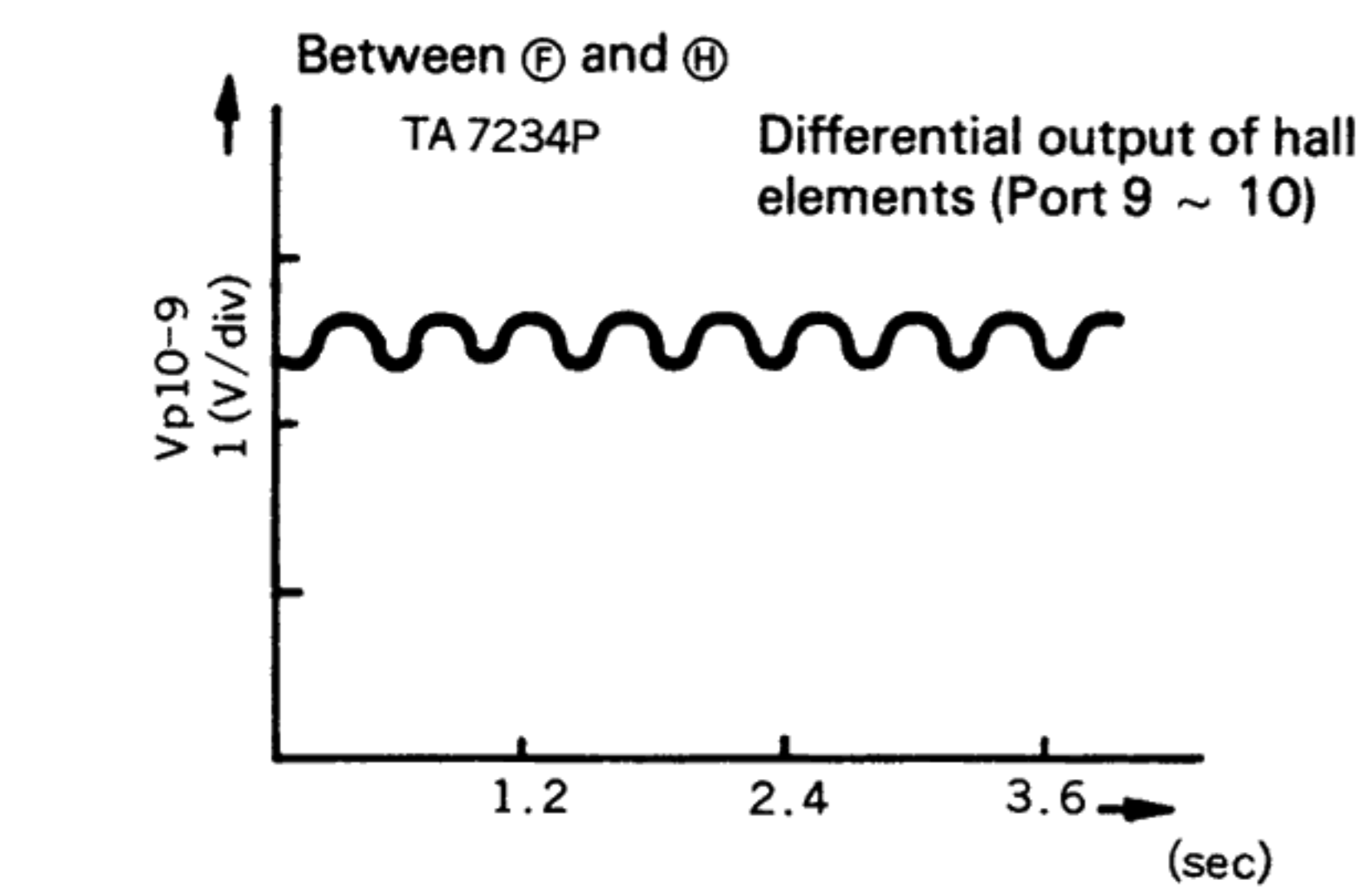
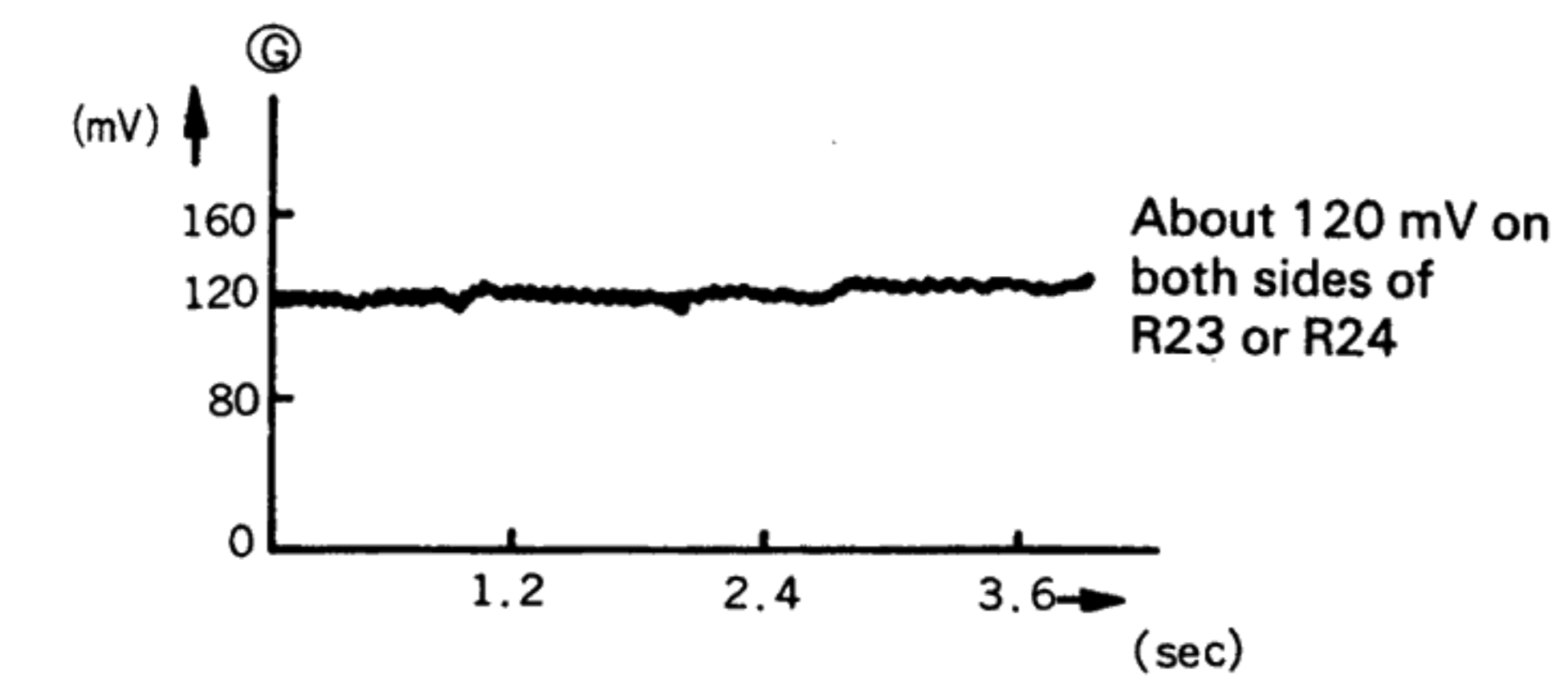
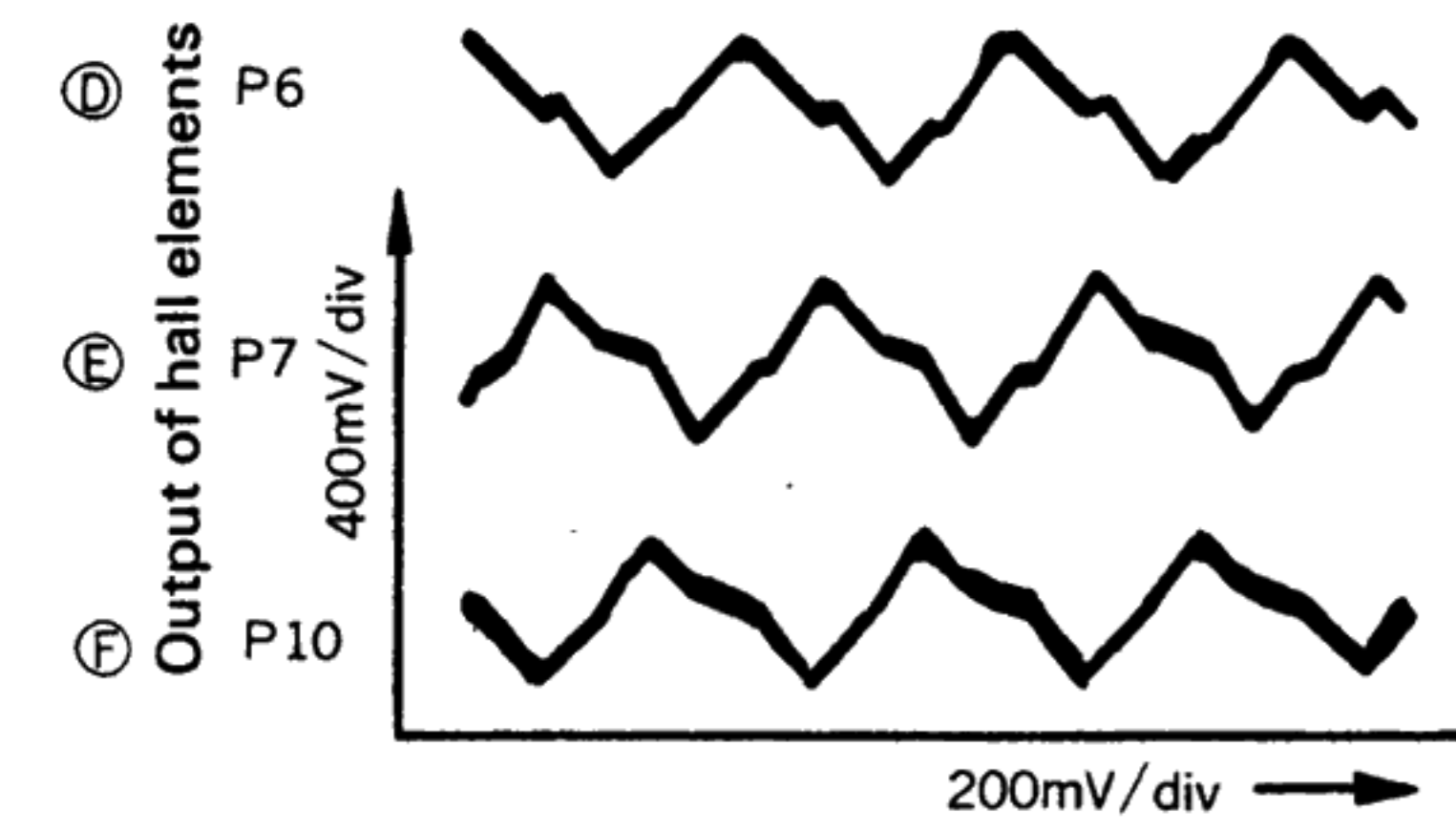
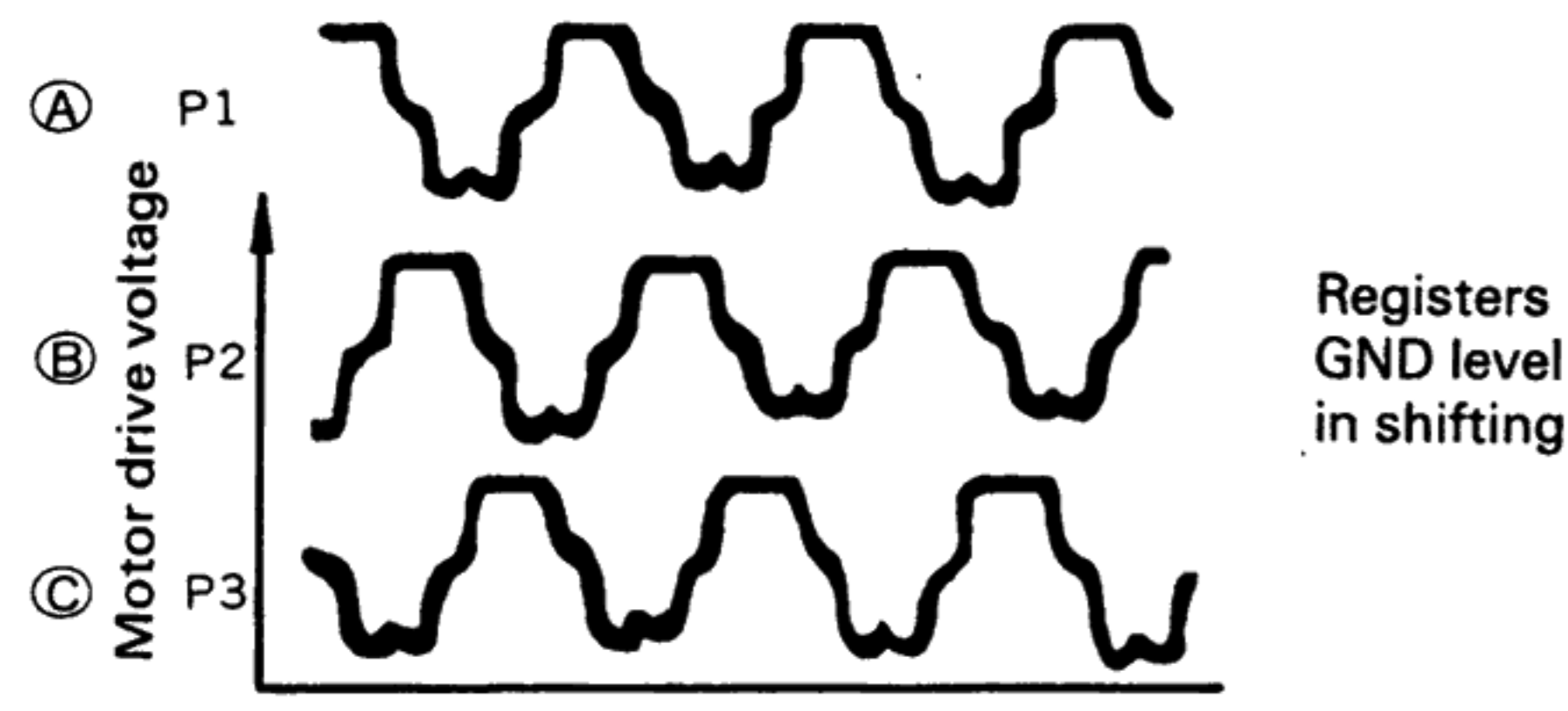

μPD7520C-028

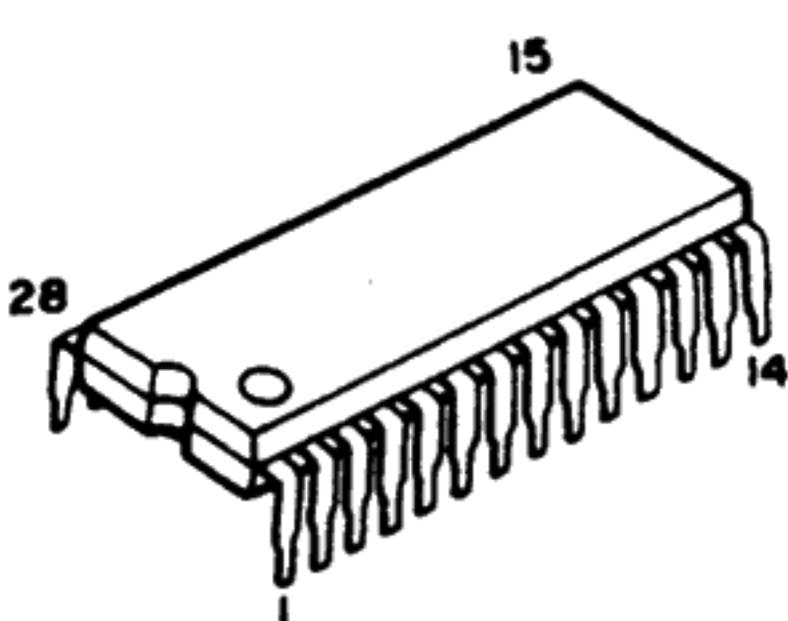

AN6562



2SA999
2SC1685
2SC2320
2SC945
2SD467

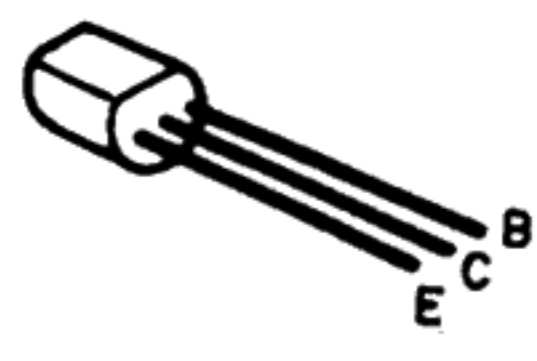

2SD882

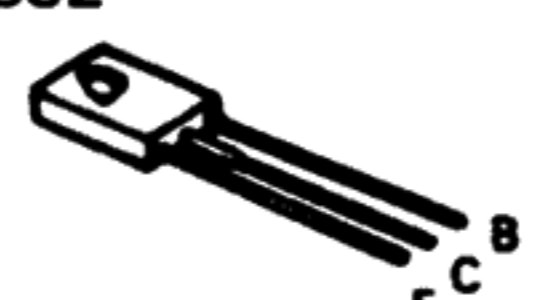

2SD330

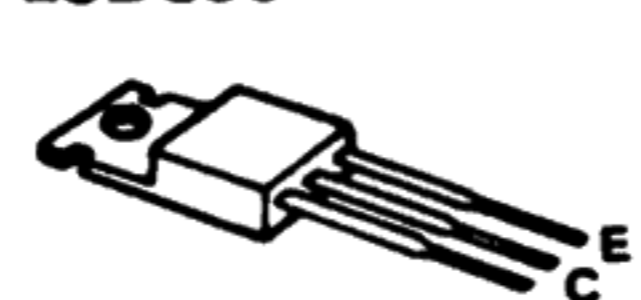

2SA1175
2SC2785



LA6358

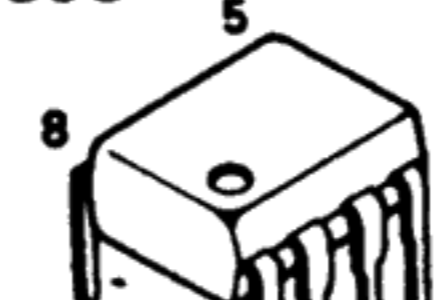

TC9142P



TA7234P

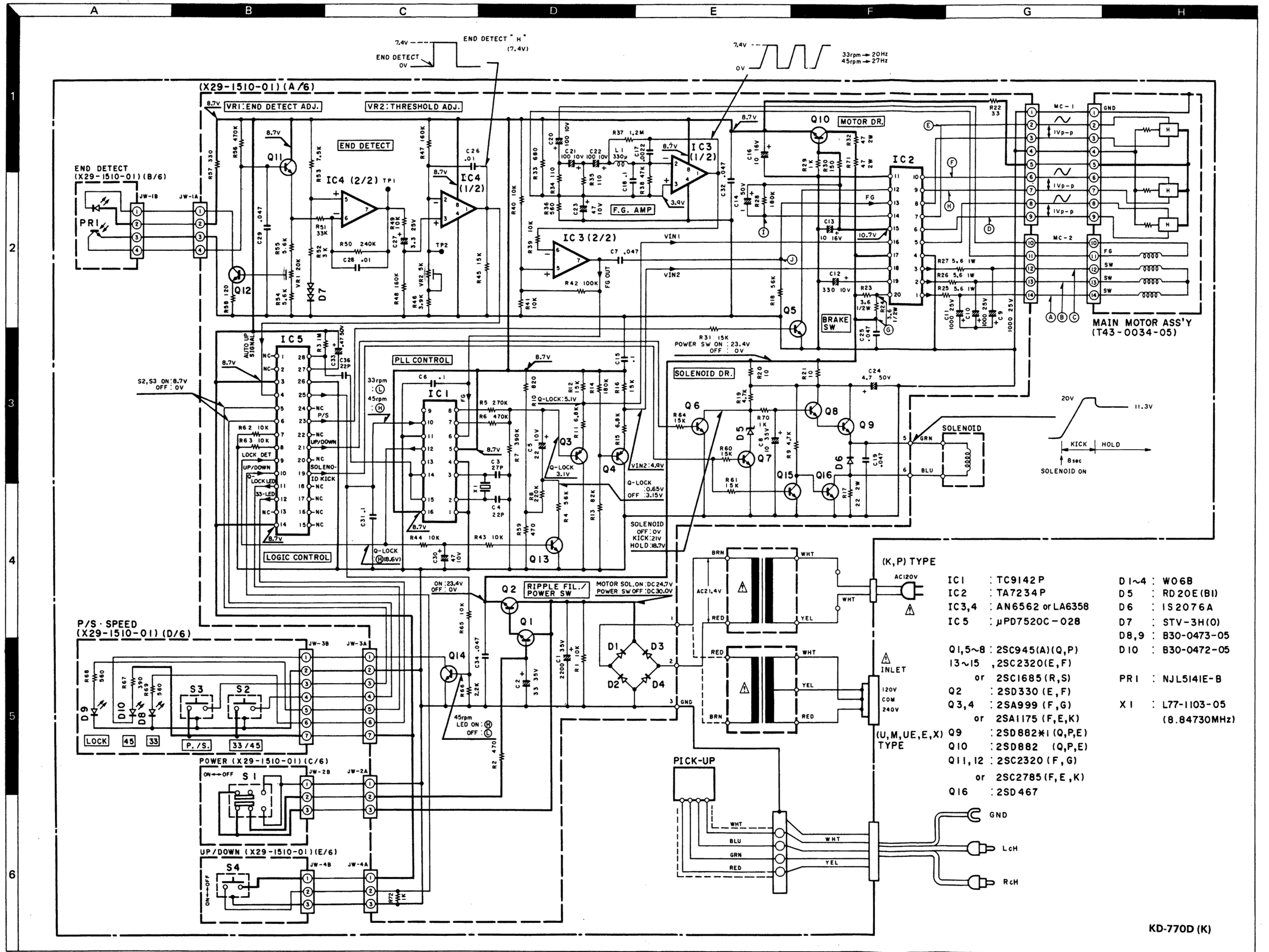

KD-770D (K)

EXPLODED VIEW

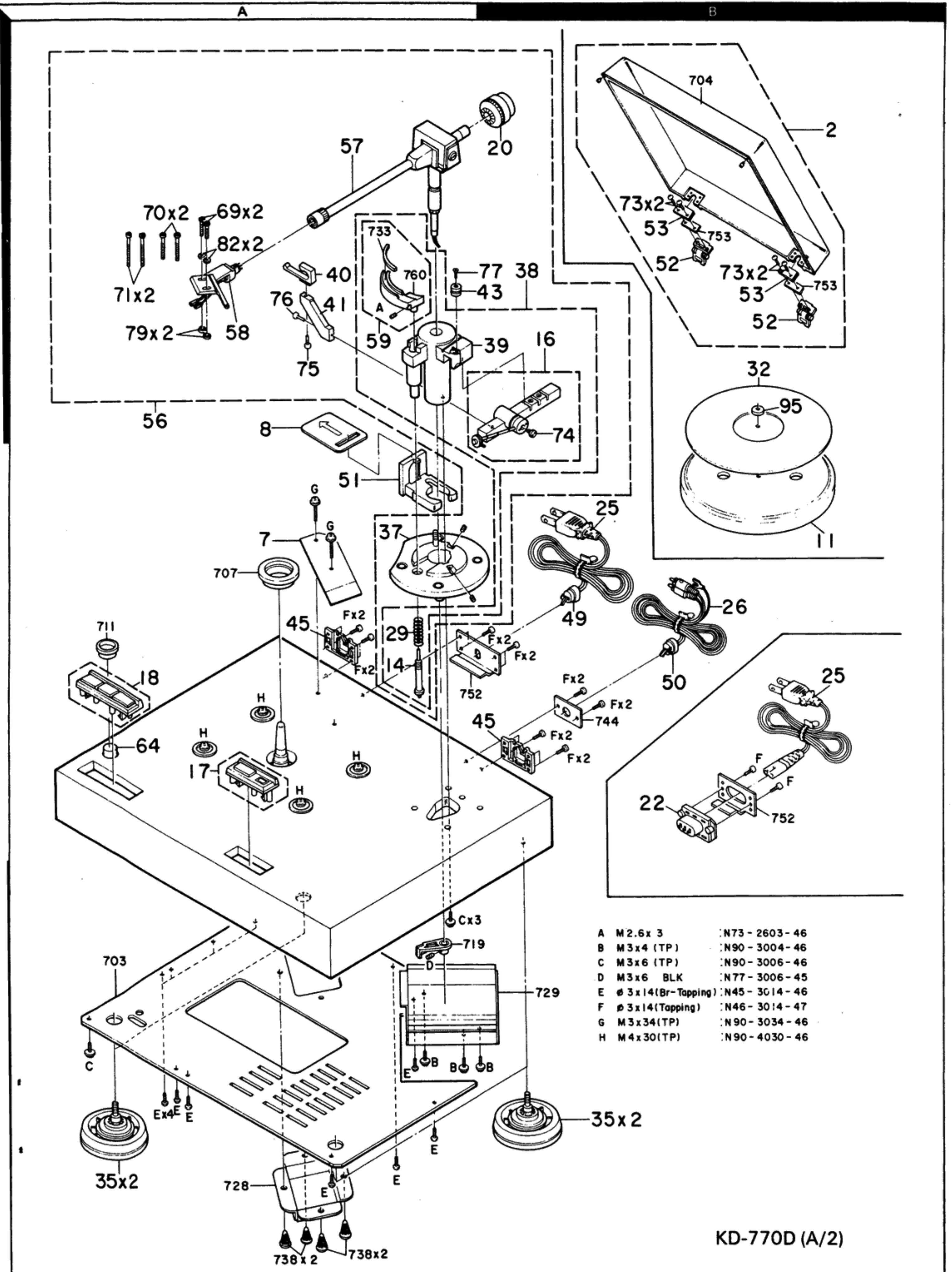

A	M 2.6 x 3	:N73-2603-46
B	M 3 x 4 (TP)	:N90-3004-46
C	M 3 x 6 (TP)	:N90-3006-46
D	M 3 x 6 BLK	:N77-3006-45
E	∅ 3 x 14 (Br-Tapping)	:N45-3014-46
F	∅ 3 x 14 (Tapping)	:N46-3014-47
G	M 3 x 34 (TP)	:N90-3034-46
H	M 4 x 30 (TP)	:N90-4030-46

KD-770D (A/2)

Parts with the exploded numbers larger than 700 are not supplied.

PARTS LIST

× New Parts

Parts without Parts No. are not supplied.

Les articles non mentionnés dans le Parts No. ne sont pas fournis.

Teile ohne Parts No. werden nicht geliefert.

Ref. No. 参照番号	Address 位置	New Parts 新	Parts No. 部品番号	Description 部品名 / 規格	Desti- nation 仕向	Re- marks 備考
KD-770D						
1	3C	*	A03-0267-12	TURNTABLE CABINET ASSY		
2	1B		A53-0057-02	DUST COVER ASSY		
5	2C		B07-1132-04	ESCUTCHEON (POWER SW)		
6	1C		B19-0510-14	MIRROR (SEARCH ARM)		
-			B46-0092-03	WARRANTY CARD	K	
-			B46-0093-03	WARRANTY CARD	P	
-			B46-0094-03	WARRANTY CARD	UUE	
-			B46-0095-03	WARRANTY CARD	UUE	
-			B46-0096-03	WARRANTY CARD	X	
-			B46-0098-03	WARRANTY CARD	E	
-		*	B50-5063-00	INSTRUCTION MANUAL (ENGLISH)	KUUE	
-		*	B50-5064-00	INSTRUCTION MANUAL (FRENCH)	PMX	
-		*	B50-5065-00	INSTRUCTION MANUAL (E,F,G,D,I)	E	
-		*	B50-5066-00	INSTRUCTION MANUAL (SP)	M	
-			B58-0223-04	CAUTION CARD	U	
-			B58-0269-04	CAUTION CARD	K	
-		*	B58-0289-04	CAUTION CARD	KUUEX	
-		*	B58-0289-04	CAUTION CARD	E	
-		*	B58-0290-04	CAUTION CARD	PM	
-			B58-0513-04	CAUTION CARD	UE	
-			B58-0518-04	CAUTION CARD	KUM	
-			B58-0518-04	CAUTION CARD	UEXE	
-			B58-0519-04	CAUTION CARD	P	
-			B59-0092-00	SERVICE DIRECTORY	UUE	
11	2B		D02-0039-15	TURNTABLE PLATTER		
14	2A		D21-1007-08	SHAFT ASSY		
16	1B		D39-0169-08	ANTI-SKATING DEVICE ASSY		
17	2C,3C		D40-0294-03	OPER ASSY (UP/DOWN)		
18	2C,3C	*	D40-0316-03	OPER ASSY (START/STOP, 33/45)		
19	1C		D40-0511-23	AUTO-UP MECHANISM ASSY		
20	1B	*	D91-0061-08	MAIN WEIGHT		
△	22		E03-0102-15	AC INLET	UMUE	
△	22		E03-0102-15	AC INLET	XE	
△	23		E22-0407-05	LUG TYPE TERMINAL STRIPS		
△	25		E30-1305-15	AC POWER CORD (INLET)	UMUE	
△	25		E30-1329-05	AC POWER CORD (INLET)	E	
△	25		E30-1342-05	AC POWER CORD (INLET)	X	
△	25		E30-1350-05	AC POWER CORD	KP	
△	26		E30-0800-05	AUDIO CORD		
29	2A		G01-1057-08	TORSION COIL SPRING (LIFTER)		
30	1C		G01-1078-04	COMPRESSION SPRING (DAMPER)		
31	1D		G13-0105-04	CUSHION (POWER TRANSFORMER)		
32	1B		G16-0355-13	TURNTABLE SHEET	PUMUE	
32	1B		G16-0355-13	TURNTABLE SHEET	XE	
32	1B		G16-0358-13	TURNTABLE SHEET	K	
-		*	H01-5010-04	ITEM CARTON CASE		
-			H10-1654-02	POLYSTYRENE FOAMED FIXTURE		
-			H10-1655-02	POLYSTYRENE FOAMED FIXTURE		
-			H10-1656-02	POLYSTYRENE FOAMED FIXTURE		
-			H10-1657-02	POLYSTYRENE FOAMED FIXTURE		

E: Scandinavia & Europe H: Audio Club K: USA P: Canada

S: South Africa T: England U: PX(Far East, Hawaii)

UE: AAFES(Europe) X: Australia M: Other Areas

△ indicates safety critical components.

PARTS LIST

× New Parts

Parts without Parts No. are not supplied.

Les articles non mentionnés dans le Parts No. ne sont pas fournis.

Teile ohne Parts No. werden nicht geliefert.

Ref. No. 参照番号	Address 位置	New Parts 新	Parts No. 部品番号	Description 部品名 / 規格	Desti- nation 仕向	Re- marks 備考
-			H10-1704-23	POLYSTYRENE FOAMED FIXTURE		
-			H12-0127-03	CARTON BOARD		
-			H12-0149-13	PACKING FIXTURE		
-			H12-0393-02	CARTON BOARD		
-			H20-0469-04	PROTECTION COVER		
-			H21-0221-04	PROTECTION SHEET		
-			H25-0029-04	PROTECTION BAG		
-			H25-0078-04	PROTECTION BAG		
-			H25-0159-04	PROTECTION BAG	M	
-			H40-0005-04	RUST PREVENTING PAPER	M	
35	3A, 3B	*	J02-0346-13	INSULATOR ASSY		
37	2A		J19-0808-08	TONEARM BASE ASSY		
38	1B		J19-0809-08	LIFTER BASE ASSY		
39	1B		J19-0810-08	LIFTER BASE (J19-0809-08ASSY)		
40	1A		J19-0811-08	TONEARM REST		
41	1A		J19-0812-08	HOLDER		
43	1B		J19-0814-08	WIRE GUIDE		
45	2D		J21-2302-05	HOLDER (A03-0263-12ASSY)		
△ 49	2B		J41-0034-05	POWER CORD BUSHING	KP	
50	2B		J42-0078-05	BUSHING (AUDIO CORD)		
51	2A		J42-0317-08	BUSHING (FOR TRANSPORT)		
52	1B		J50-0314-25	HINGE (A53-0213-22ASSY)		
53	1B		J50-0322-04	HINGE PLATE (A53-0213-22ASSY)		
54	2D		J61-0050-15	WIRE BAND (INSIDE TT CABINET)		
56	1A	*	J91-0204-05	TONEARM ASSY		
57	1A	*	J91-0212-08	PICKUP ARM (J19-0204-05ASSY)		
58	1A		J92-0093-08	SHELL		
59	1A		J99-0020-08	TONEARM LIFTER ASSY		
-			J61-0054-05	WIRE BAND		
-			J61-0307-05	WIRE BAND	XE	
63	3C, 3D		K29-0911-14	KNOB (IN OPER ASSY)S/S, 33/45		
64	2A, 2C		K29-1445-04	KNOB (POWER)		
△ 66	1D	*	L01-3222-25	POWER TRANSFORMER (H. K. ONLY)	M	
△ 66	1D		L01-6511-25	POWER TRANSFORMER	KP	
△ 66	1D		L01-6514-25	POWER TRANSFORMER	UMJEX	
△ 66	1D		L01-6514-25	POWER TRANSFORMER	E	
69	1A		N09-0850-04	CARTRIDGE MOUNT SCREW(M2.6X10)		
70	1A		N09-0851-04	CARTRIDGE MOUNT SCREW(M2.6X15)		
71	1A		N09-0852-04	CARTRIDGE MOUNT SCREW(M2.6X20)		
72	1D		N09-0985-04	TAPPING SCREW(MOTOR FRAME)		
73	1B		N09-1238-05	TAPTITE SCREW(Ø3X12)DUST COVER		
74	1B		N09-1311-08	STEPPED SCREW(ANTI-SKATING)		
75	1A		N09-1374-08	SET SCREW (Ø2X5)TONEARM REST		
76	1A		N09-1375-08	SET SCREW (Ø2X7)REST HOLDER		
77	1B		N09-1376-08	SET SCREW (Ø2X8)WIRE GUARD		
79	1A		N14-0412-04	CIRCULAR NUT(M2.6)CARTRIDGE		
82	1A		N19-0175-09	FLAT WASHER		
83	1D		N19-0186-14	FLAT WASHER		
84	3D		N19-0599-14	M TYPE WASHER		
87	1C		N29-0219-05	RETAINING RING		
90	2D		T43-0034-05	DIRECT DRIVE MOTOR		
91	1C		T94-0067-05	MAGNETIC PLUNGER		
95	1B		W01-0329-04	EP ADAPTER		

E: Scandinavia & Europe H:Audio Club K: USA

P: Canada

S: South Africa

T: England

U: PX(Far East, Hawaii)

UE: AAFES(Europe)

X: Australia

M: Other Areas

△ indicates safety critical components.

PARTS LIST

※ New Parts

Parts without Parts No. are not supplied.

Les articles non mentionnés dans le Parts No. ne sont pas fournis.

Teile ohne Parts No. werden nicht geliefert.

Ref. No. 参照番号	Address 位置	New Parts 新	Parts No. 部品番号	Description 部品名 / 規格	Desti- nation 仕向	Re- marks 備考
-			W01-0302-08	HEXAGAN WRENCH KEY		
CONTROL CIRCUIT (X29-1510-01)						
D8 ,9 D10	2C 2C		B30-0473-05 B30-0472-05	LED(PR5734S) 33, LOCK LED(BG5734S) 45		
C1 C2 C3 C4 C5			C90-1238-05 CE04FW1V330M CC45FSL1H270J CC45FSL1H220J CE04FW1A220M	ELECTRØ 2200UF 35WV ELECTRØ 33UF 35WV CERAMIC 27PF J CERAMIC 22PF J ELECTRØ 22UF 10WV		
C6 C7 C8 C9 -11 C12			C91-0699-05 CK45FF1H473Z CE04FW1V100M C90-0855-05 CE04FW1A331M	CERAMIC 0.1UF K CERAMIC 0.047UF Z ELECTRØ 10UF 35WV ELECTRØ 1000UF 25WV ELECTRØ 330UF 10WV		
C13 C14 C15 C16 C17			CE04FW1C100M C90-0719-05 C91-0699-05 CE04FW1C100M CQ92FM1H222J	ELECTRØ 10UF 16WV ELECTRØ 1UF 50WV CERAMIC 0.1UF K ELECTRØ 10UF 16WV MYLAR 2200PF J		
C18 C19 C20 C21 C22			C91-0699-05 CK45FF1H473Z CE04FW1A101M CE04FW1A101M CE04FW1A101M	CERAMIC 0.1UF K CERAMIC 0.047UF Z ELECTRØ 100UF 10WV ELECTRØ 100UF 10WV ELECTRØ 100UF 10WV		
C23 C24 C25 C26 C27			CE04FW1A470M CE04FW1H4R7M CK45FF1H473Z CK45FF1H103Z C90-1285-05	ELECTRØ 47UF 10WV ELECTRØ 4.7UF 50WV CERAMIC 0.047UF Z CERAMIC 0.01UF Z ELECTRØ 3.3UF 25WV		
C28 C29 C30 C31 C32			CK45FF1H103Z CK45FF1H473Z CE04FW1A470M C91-0699-05 CK45FF1H473Z	CERAMIC 0.01UF Z CERAMIC 0.047UF Z ELECTRØ 47UF 10WV CERAMIC 0.1UF K CERAMIC 0.047UF Z		
C33 C34 C36			CE04FW1HR47M CK45FF1H473Z CC45SL1H220J	ELECTRØ 0.47UF 50WV CERAMIC 0.047UF Z CERAMIC 22PF J		
L1 X1			L40-3311-12 L77-1103-05	SMALL FIXED INDUCTØR(330UH,K) CRYSTAL RESONATOR		
-			N19-0099-04	FLAT WASHER		
R2 R17 R20 ,21 R22 R23 ,24			RD14GB2E471J RS14GB3D220J R92-0513-05 RD14GB2E330J RD14GB2H3R6JMA	FL-PROOF RD 470 J 1/4W FL-PROOF RS 22 J 2W FL-PROOF RD 10 G 1/4W FL-PROOF RD 33 J 1/4W FL-PROOF RD 3.6 J 1/2W		
R25 -27 R32 R71 VR1 VR2			RS14GB3A5R6J RS14GB3D470J RS14GB3D470J R12-3301-05 R12-2302-05	FL-PROOF RS 5.6 J 1W FL-PROOF RS 47 J 2W FL-PROOF RS 47 J 2W TRIMMING PØT(20K)DET START TRIMMING PØT(5K) THRESHØLD		
S1 S2 -4	2C 2C		S40-2326-05 S40-1065-05	PUSH SWITCH(POWER) PUSH SWITCH(UP/DOWN,S/S,33/45)		

E: Scandinavia & Europe H: Audio Club K: USA

P: Canada

S: South Africa T: England U: PX(Far East, Hawaii)

UE: AAFES(Europe) X: Australia M: Other Areas

▲ indicates safety critical components.

PARTS LIST

* New Parts

Parts without Parts No. are not supplied.

Les articles non mentionnés dans le Parts No. ne sont pas fournis.

Teile ohne Parts No. werden nicht geliefert.

Ref. No. 参照番号	Address 位置	New Parts 新	Parts No. 部品番号	Description 部品名 / 規格	Desti- nation 仕向	Re- marks 備考
D1 -4			W06B	DIODE		
D5			RD20E(B1)	ZENER DIODE		
D6			1S2076A	DIODE		
D7			STV-3H(0)	VARISTOR		
IC1			TC9142P	IC QUARTZ PLL CONTROL		
IC2			TA7234P	IC MOTOR DRIVER		
IC3 ,4			AN6562	IC OP AMP		
IC3 ,4			LA6358	IC OP AMP		
IC5			UPD7520C-028	IC MICROPROCESSOR		
PR1			NJL5141E-B	OPTO ISOLATOR		
Q1			2SC1685(R,S)	TRANSISTOR		
Q1			2SC2320(E,F)	TRANSISTOR		
Q1			2SC945(A)(Q,P)	TRANSISTOR		
Q2			2SD330(E,F)	TRANSISTOR		
Q3 ,4			2SA1175(F,E,K)	TRANSISTOR		
Q3 ,4			2SA999(F,G)	TRANSISTOR		
Q5 -8			2SC1685(R,S)	TRANSISTOR		
Q5 -8			2SC2320(E,F)	TRANSISTOR		
Q5 -8			2SC945(A)(Q,P)	TRANSISTOR		
Q9			2SD882(Q,P,E)	TRANSISTOR		
Q10		*	2SD882*1(Q,P,E)	TRANSISTOR		
Q11 ,12			2SC2320(F,G)	TRANSISTOR		
Q11 ,12			2SC2785(F,E,K)	TRANSISTOR		
Q13 -15			2SC1685(R,S)	TRANSISTOR		
Q13 -15			2SC2320(E,F)	TRANSISTOR		
Q13 -15			2SC945(A)(Q,P)	TRANSISTOR		
Q16			2SD467	TRANSISTOR		

E: Scandinavia & Europe H: Audio Club K: USA

P: Canada

S: South Africa

T: England

U: PX(Far East, Hawaii)

UE: AAFES(Europe)

X: Australia

M: Other Areas

 indicates safety critical components.

PACKING

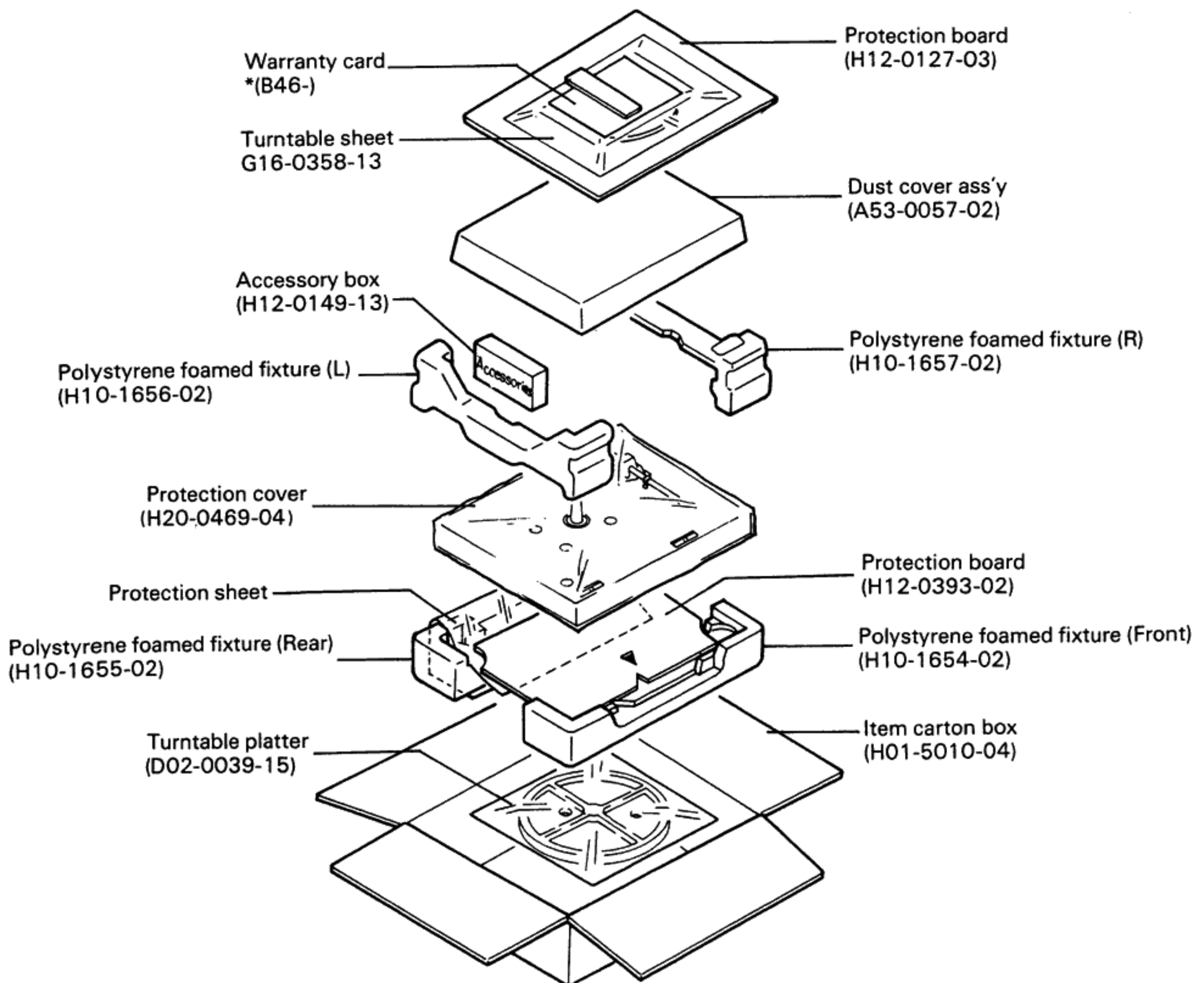
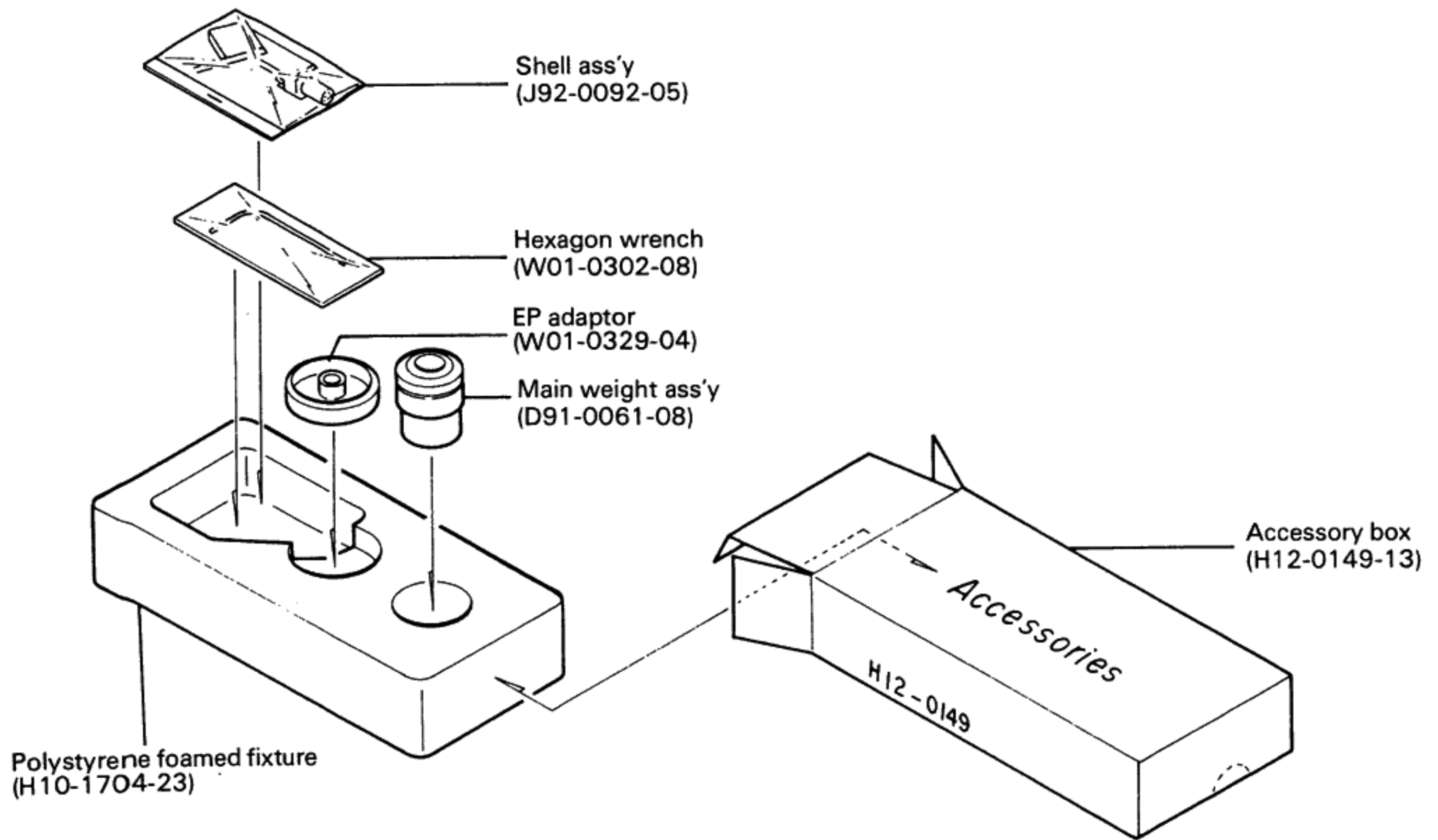

WORLD MAP & AREA CODE

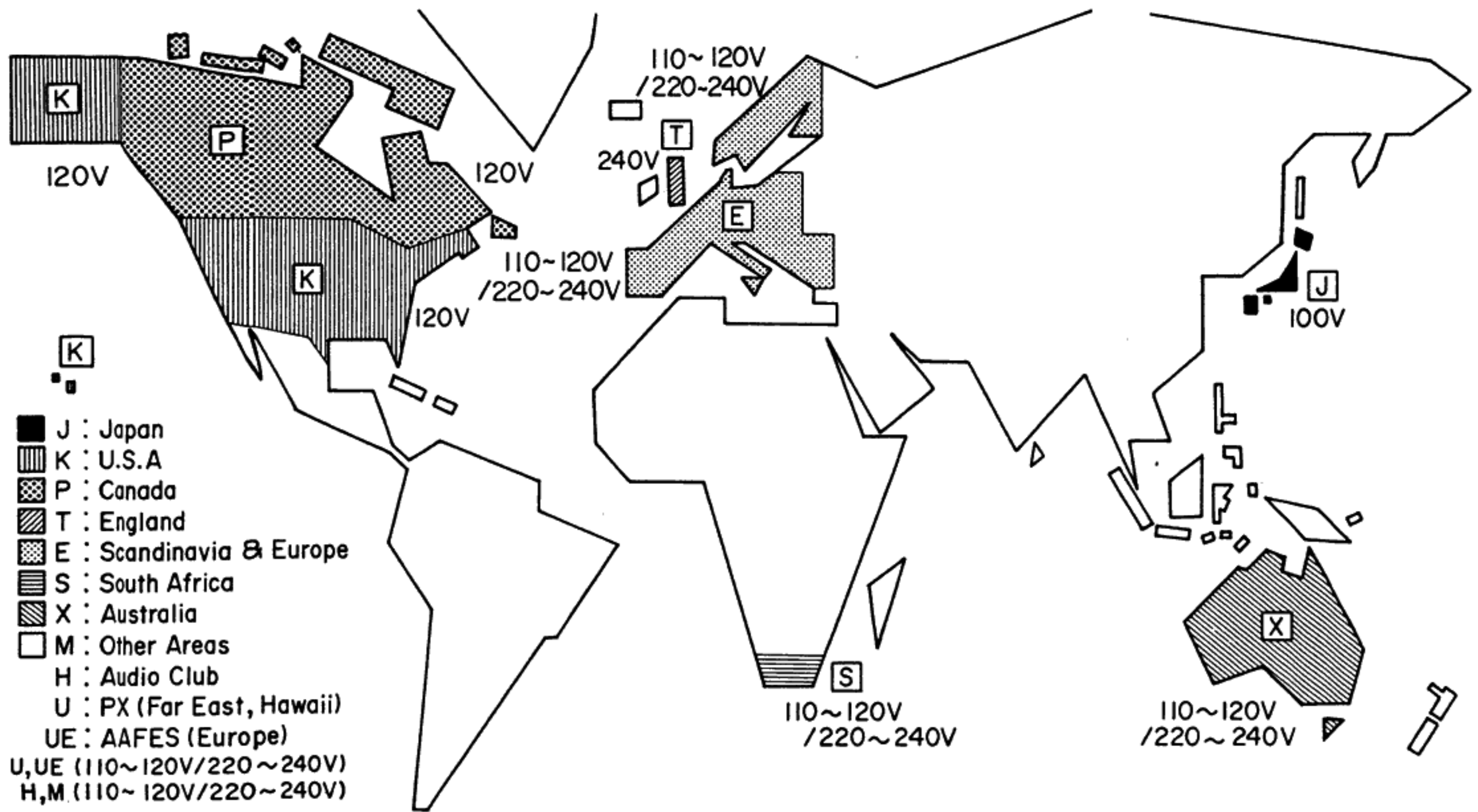

Note:

Component and circuitry are subject to modification to insure best operation under differing local conditions. This manual is based on, the U.S. (K) standard, and provides information on regional circuit modification through use of alternate schematic diagrams, and information on regional component variations through use of parts list.

TRIO-KENWOOD CORPORATION

Shionogi Shibuya Building, 17-5, 2-chome Shibuya, Shibuya-ku, Tokyo 150, Japan

KENWOOD ELECTRONICS

1315 E. Watsoncenter Rd. Carson, California 90745; U.S.A.

75 Seaview Drive, Secaucus, New Jersey 07094, U.S.A.

TRIO-KENWOOD CANADA INC.,

1070 Jayson Court, Mississauga, Ontario, Canada L4W 2V5

TRIO-KENWOOD ELECTRONICS, N.V.

Leuvensesteenweg 504 B-1930 Zaventem, Belgium

TRIO-KENWOOD ELECTRONICS GmbH

Rudolf-Brass-Str. 20, 6056 Heusenstamm, West Germany

TRIO-KENWOOD FRANCE S.A.

5, Boulevard Ney, 75018 Paris, France

TRIO-KENWOOD (AUSTRALIA) PTY. LTD. (INCORPORATED IN N.S.W.)

4E Woodcock Place, Lane Cove, N.S.W. 2066, Australia

KENWOOD & LEE ELECTRONICS, LTD.

Wang Kee Building, 5th Floor, 34-37, Connaught Road, Central, Hong Kong