

TTS-3000



TURNTABLE SYSTEM

Specifications

Speeds:	33 $\frac{1}{3}$ rpm and 45 rpm
Speed control range:	$\pm 5\%$
Start-up time:	within one second
Wow and flutter:	Less than 0.05% rms
Signal-to-noise ratio:	greater than 60 db (NAB standard)
Turntable vertical motion:	within ± 0.05 mm
Power requirements:	100, 117, 220 or 240V 50/60 Hz
Power consumption:	4 VA
Turntable:	12", 3-lb 5-oz diecast aluminum
Weight:	approx 12 lb 12 oz
Dimensions:	14 $\frac{1}{16}$ " W x 5 $\frac{1}{8}$ " H x 15" D

SONY[®]
SERVICE MANUAL

TABLE OF CONTENTS

	<i>Page</i>
General Information	1
Specifications.....	1
Circuit Description	1
Disassembly	3
Maintenance	3
Troubleshooting Charts	6
Schematic Diagram	8
Mounting Diagram	8
Exploded Diagram	10

CAUTION

The early model, which is not described in this manual, is some different in electrical circuit. The difference is not so great as you might think of, because the principle of this servo-control system is not different. If a circumstance makes you to replace some unidentified components in that model, ask SONY European Service Center in Belgium, or directly to SONY Tokyo Office in Japan.

Please read the "CIRCUIT DESCRIPTION" carefully for your servicing reference. It will provide the basic knowledge to you of how a servo-controlled turntable work and principles behind the major adjustment.

GENERAL INFORMATION

The TTS-3000 employs a slow-speed servo-controlled motor to drive the turntable. The use of a slow speed (300 rpm) motor eliminates much of the noise and rumble that originates in mechanical speed-reducing systems. This unique servo system effectively compares motor speed with a very stable frequency reference. Any error in motor speed results in a correction in the current supplied to the motor. The speed reference is entirely independent of outside influence. Line frequency is used only to power the strobe light.

SPECIFICATIONS

Speeds:	33½ rpm and 45 rpm
Speed control range:	±5%
Start-up time:	within one second
Wow and flutter:	Less than 0.05% rms
Signal-to-noise ratio:	greater than 60 db (NAB standard)
Turntable vertical motion:	within ±0.05 mm
Power requirements:	100, 117, 220 or 240V 50/60 Hz
Power consumption:	4 VA
Turntable:	12", 3-lb 5-oz diecast aluminum
Weight:	approx 12 lb 12 oz
Dimensions:	14¾" W x 5½" H x 15" D

CIRCUIT DESCRIPTION

Basic Principle. Basic servo action is illustrated in the block diagram of Fig. 1. In this system the rotational speed of the turntable is measured by a tone generator, a high-frequency A-C generator that is coupled to the shaft of the drive motor. This A-C signal, whose frequency is proportional to speed, is amplified and limited to remove all amplitude variations. The signal is then passed through an RC filter which serves as the speed reference for the system. The output of this filter rises when speed exceeds

the design figure and falls if speed falls below the design point.

Following the filter is a detector, which is simply a full-wave rectifier and ripple filter. The output of the detector is a d-c voltage that controls the conduction of a two-stage d-c amplifier which, in turn, controls the current supplied to the motor.

Operating characteristics of the servo system are shown on the graph of Fig. 2. The dashed line shows frequency-versus-speed relationship for the tone generator. The solid graph is the response of the filter. A stable operating point for the system occurs where the two graphs cross, and the system acts to maintain this operating point. For example, if the motor should turn faster (perhaps due to a decrease in mechanical load) the output frequency of the tone generator would rise. This would cause a drop in the output of the filter and a subsequent drop in motor current and speed. Thus the system automatically corrects changes in rotational speed regardless of the cause. A very tight control of speed is maintained because the slope of the filter response is very steep at the operating point (70 db per octave). Thus a slight change in speed results in a large correction current.

Starting Circuit. When the motor is not turning the output of the tone generator is zero and servo action cannot be effected. Thus, an auxiliary system is needed to start the motor and bring it up to speed. This auxiliary system is a transistor switch that senses the output of the limiter. When limiter output is zero, the transistor switch is open and a heavy forward bias is placed on the d-c amplifier that controls motor current. As soon as the motor comes up to speed, the transistor switch is saturated and the fixed-bias circuit is effectively removed.

Circuit Analysis. Refer to the schematic diagram on page 8. Tone generator output appears across C25 on the printed board. The signal is amplified by X1, a conventional common-emitter amplifier. The double-diode limiter conducts whenever signal amplitude exceeds the barrier potential (0.7 volts) for the diode. Thus, the output signal is limited to about 1.4 volts (peak-to-peak).

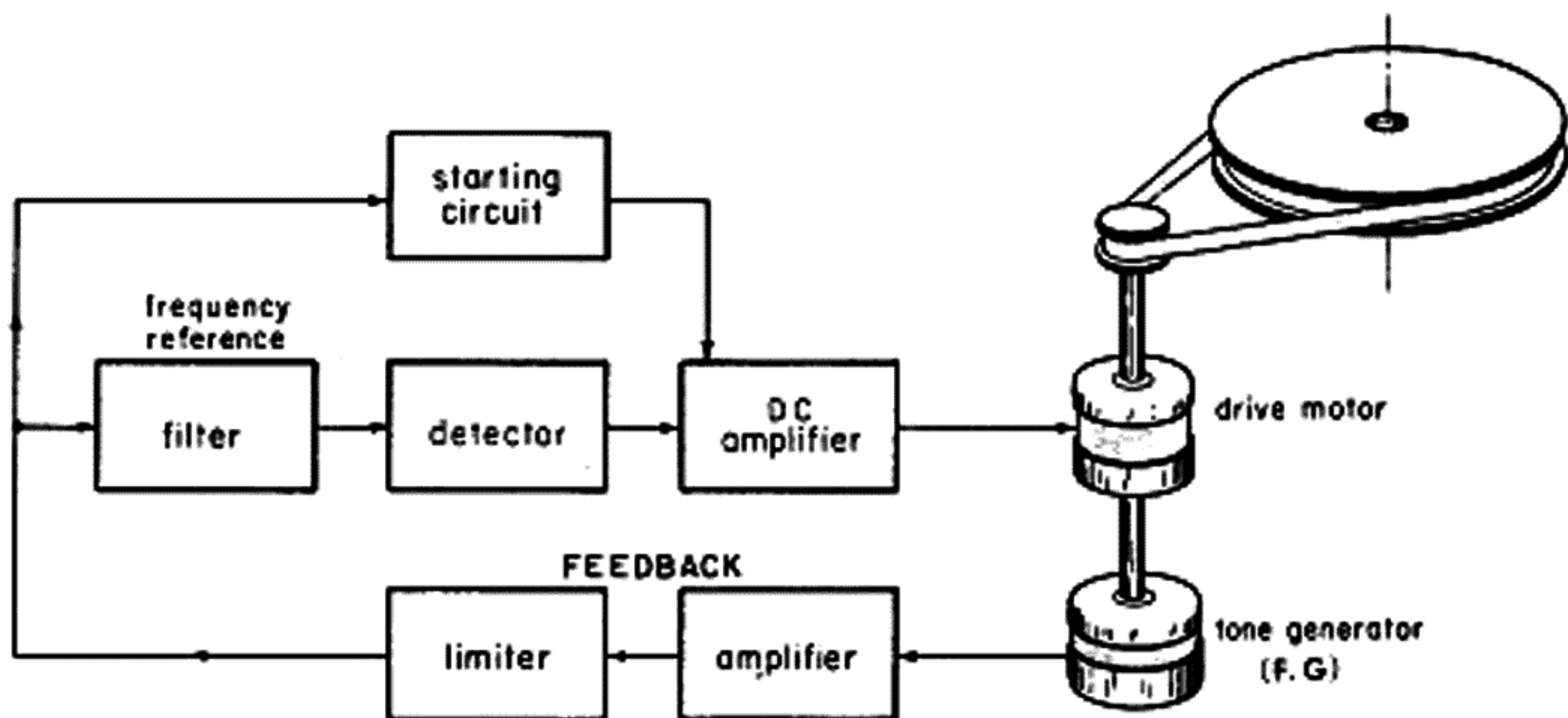

Fig. 1

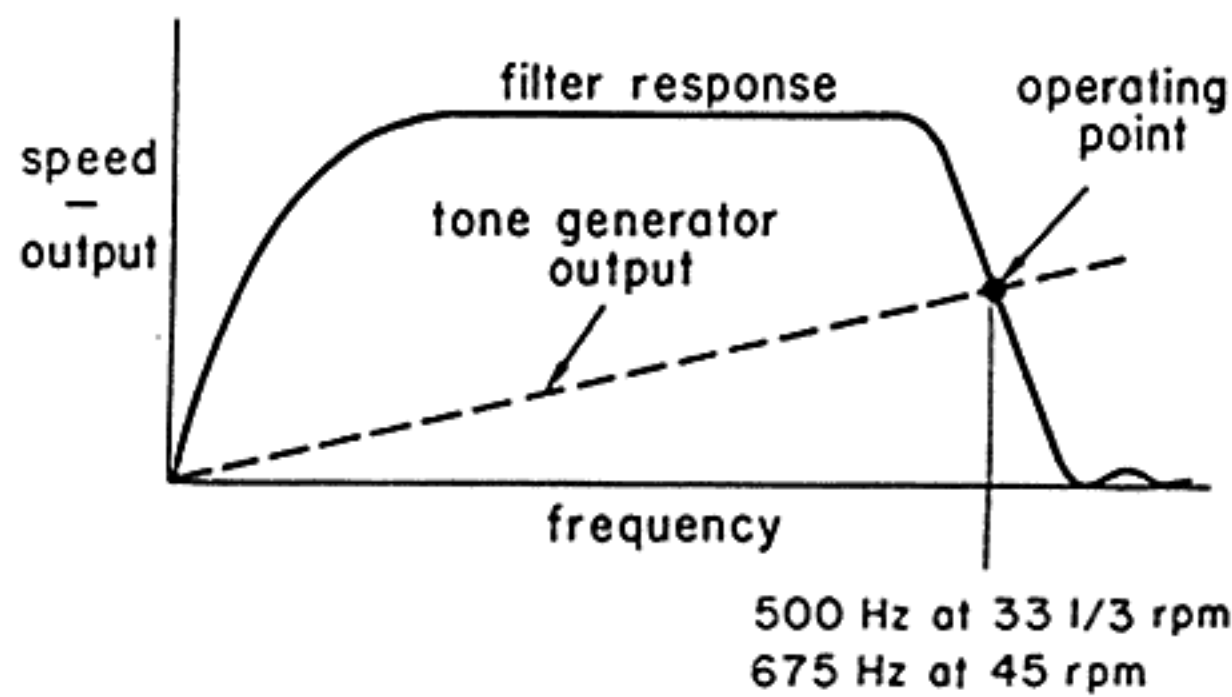

Fig. 2

Following the limiter are two separate RC filters; either filter is selected to suit the selected operating speed by the ganged switches S1 and S2. These filters are of the twin — T type and make use of phase-shift cancellation to achieve very sharp cutoff at the desired frequencies. R10 and R16 are used to “tune” the filters to the correct cutoff frequencies.

Transistor X2, an emitter follower, combines the outputs of both legs of the selected filter and provides a high input impedance to prevent loading of the filter circuits. The coupling circuit between X2 and X3 contains a voltage divider to give some control over operating speed. Control R20 is the fine speed control and is an operating control.

The output of X3 is transformer coupled to a full-wave rectifier consisting of D1 and D2 and the ripple filter C18. An emitter follower, X5, supplies the detector output to the output d-c amplifier X7. Collector current of X7 flows in the motor. The diode D6 protects the output transistor from voltage surges that are induced in the motor windings when the equipment is turned off.

Starting Circuit. Transistor X4 is cut off when there is no output from the limiter. In that case a forward bias is placed on the d-c amplifier X5 by R30, R29, D3 and R28. As a result a heavy current is supplied to the motor to start it.

As the motor/tone generator come up to speed an a-c output appears at the limiter. This signal is coupled through R27 and C17 to D5 and X4. D5 shorts out negative signal peaks and so develops a positive voltage at the base of X4. X4 saturates, effectively putting the junction of R30 and R29 at ground potential. At this time there is also a positive output from the detector. Thus, D3 is reverse biased and the starting circuit is effectively disconnected from the base of X5.

Power Supply. A positive +12.3 volts for the system is provided by the bridge rectifier consisting of D8-D10. The full output of the supply feeds the motor circuit and X7 in series. Power for all other circuits is supplied by the series regulator X6 whose base is returned to a reference 6.7 volts by the Zener diode D4.

Strobe. The strobe unit, located at the front-center of the turntable well, provides a means of checking turntable speed against the local power-line frequency. Flashes from the neon lamp (100 or 120 flashes per second) are viewed through the plastic skirt attached to the turntable. Speed

is adjusted to make the “bars” of the display appear to stand still.

Since the turntable operates from a d-c source, operation is entirely independent of the power frequency. The power frequency is used only as a check of turntable speed. However the portion of the turntable skirt used with the strobe unit must correspond with the power-line frequency. A mask, located beneath the turntable skirt, selects the band on the turntable skirt to suit 50- or 60-Hz operation. Figure 3a shows the mask positioned properly for 60-Hz operation. To set up the strobe for 50-Hz operation, remove the two screws that secure the strobe mask, turn it over and reinstall the screws. See Fig. 3b. Make sure that the mask is pushed down flush against the inner surface of the turntable well before tightening the mounting screws.

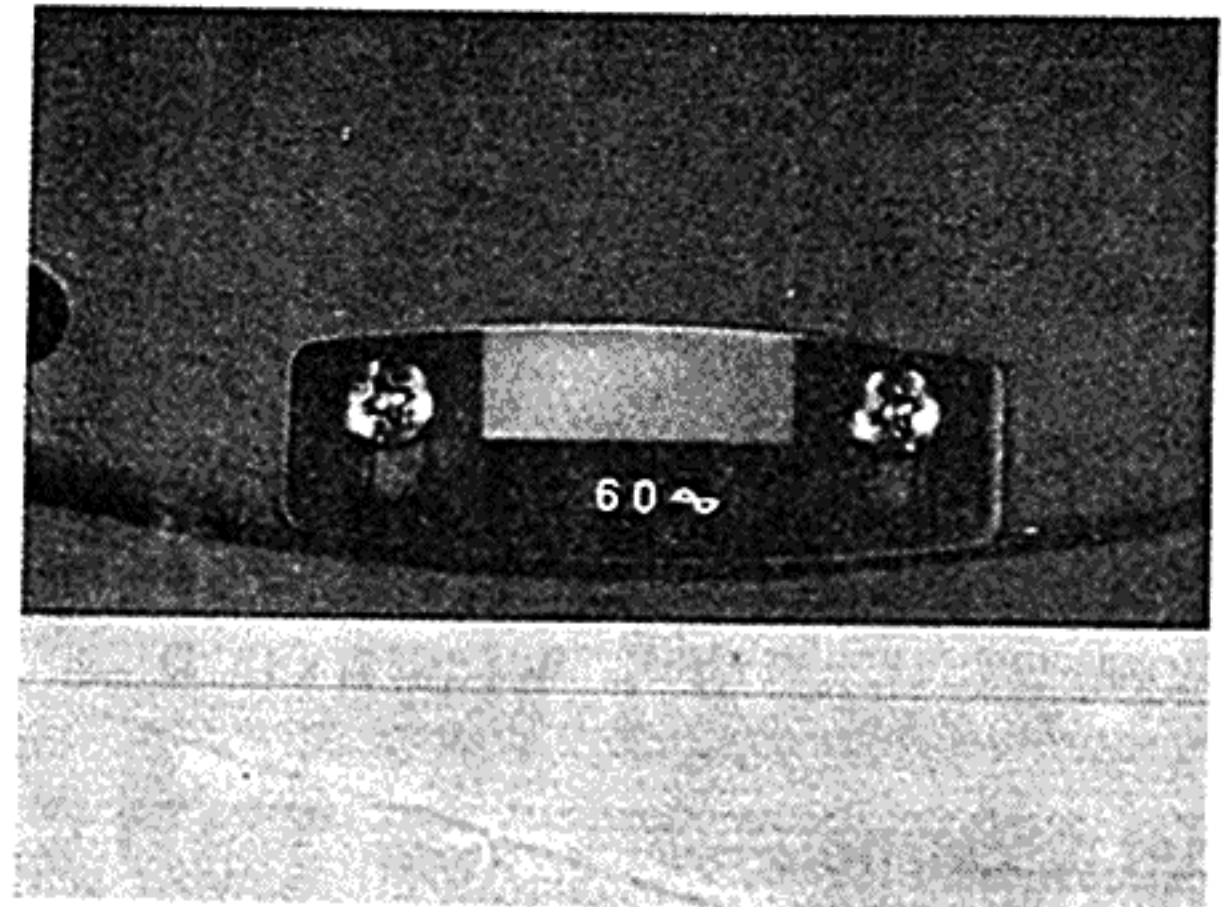

(a)

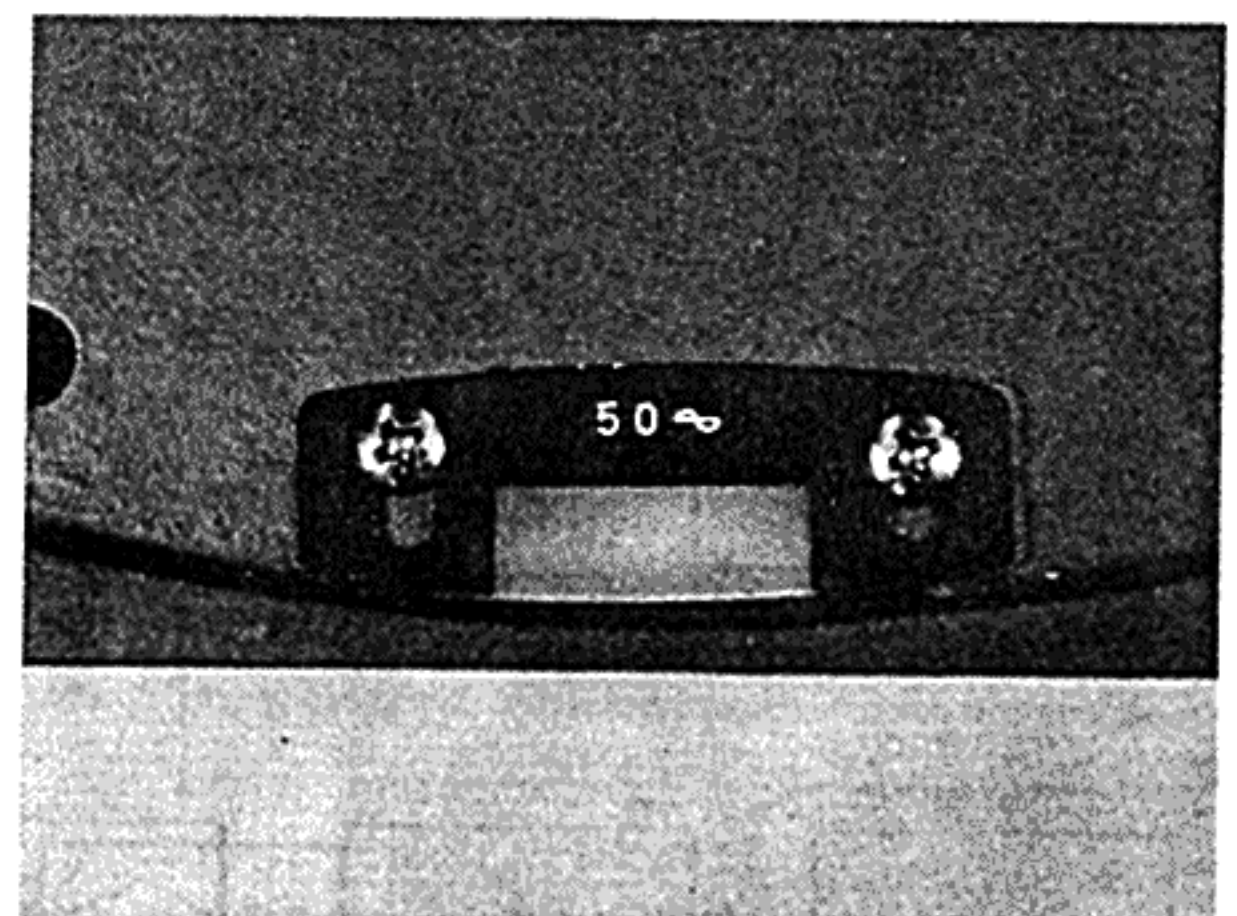

(b)

Fig. 3

Voltage Selector. The voltage selector sets up the proper power transformer connections to suit local line-voltage conditions.

Remove the two screws that secure the cover for the voltage selector, and lift off the cover. See Fig. 4. Pull out the plug and reinsert it into the voltage-selector receptacle so that the white arrow points to the proper line voltage. Replace the cover and its mounting screws.

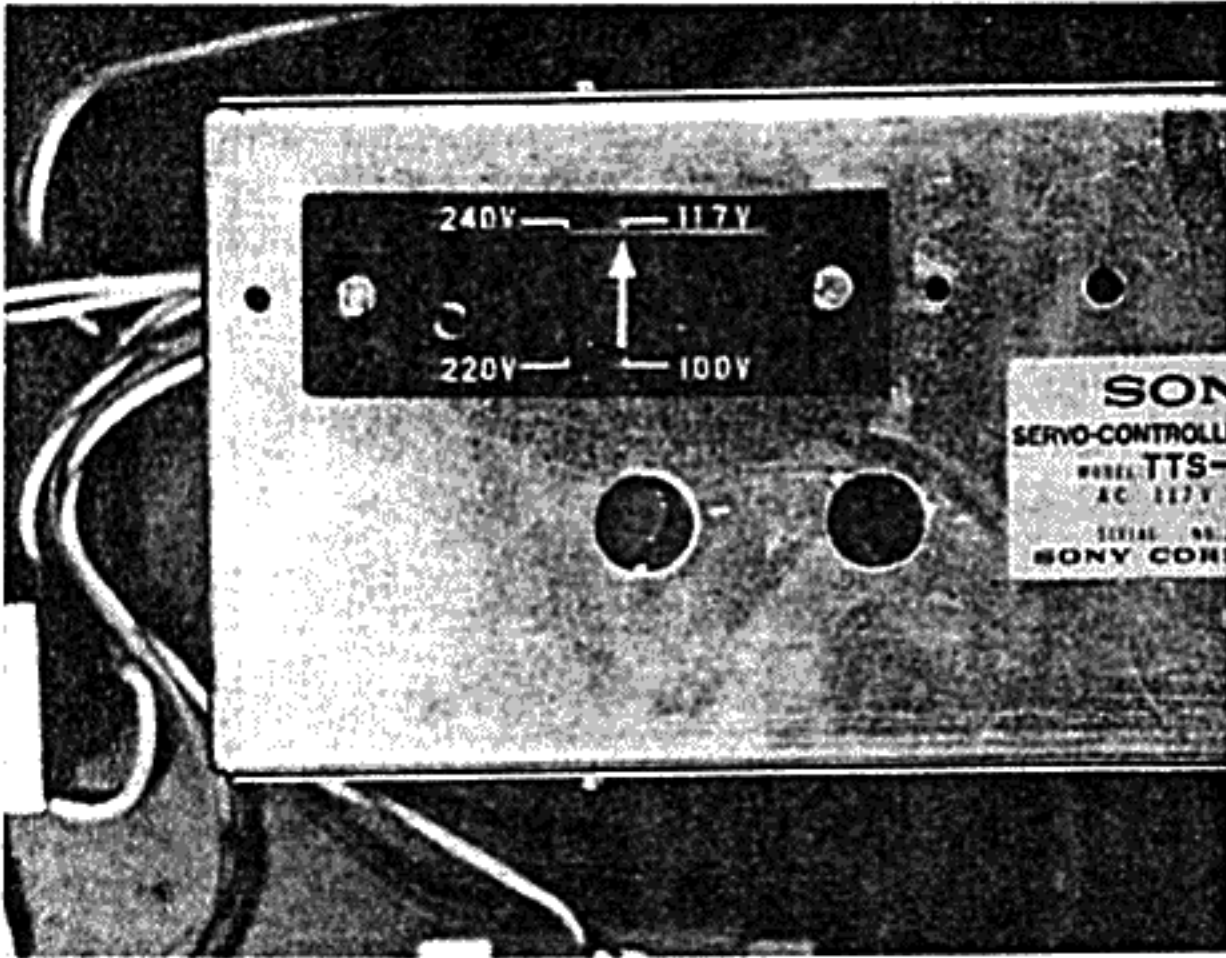

Fig. 4

DISASSEMBLY

The turntable base is secured to the motor board in one of two ways—by 4 wood screws inserted from the top of the cast turntable base or by 4 machine screws threaded into the base from the bottom of the motor board as shown in Fig. 5a and 5b. To remove the unit for service, pull off the turntable and remove the four mounting screws.

To service the servo section, turn the turntable base over and rest it on a padded work surface. The entire servo unit can be removed for service by removing the four mounting screws and flat washers.

The printed-circuit board is exposed for service and tests by removing the side panel that faces toward the strobe unit.

MAINTENANCE

Removal of turntable

- (1) Remove the rubber mat from the turn table.
- (2) Insert both your thumbs into two holes of the turntable with one of the thumbs thrusting inside of the rubber belt to hook it off, as shown in Fig. 6
- (3) Lift up the turntable carefully.
Caution: Handle the outer strobo disc of the turntable with care.

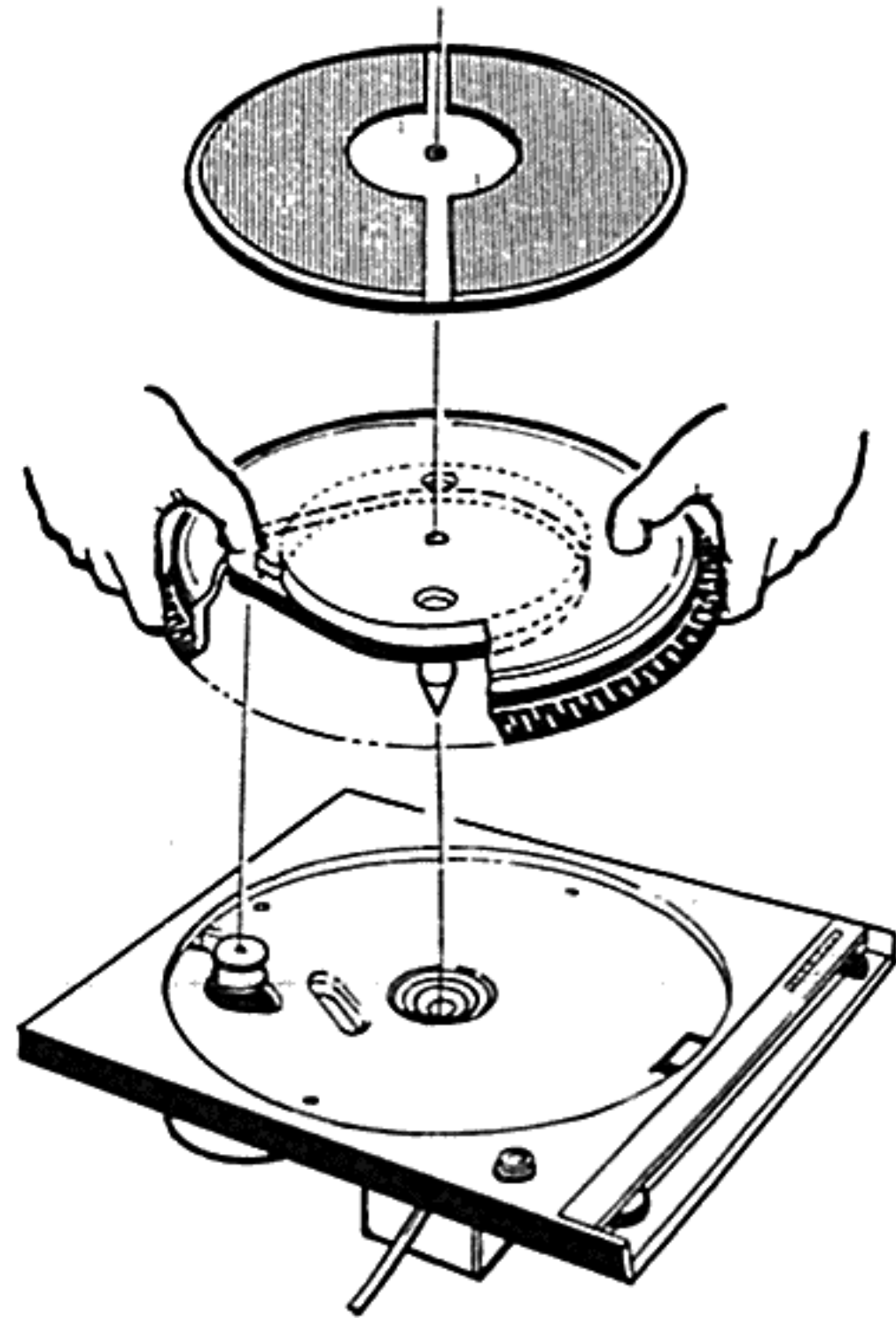
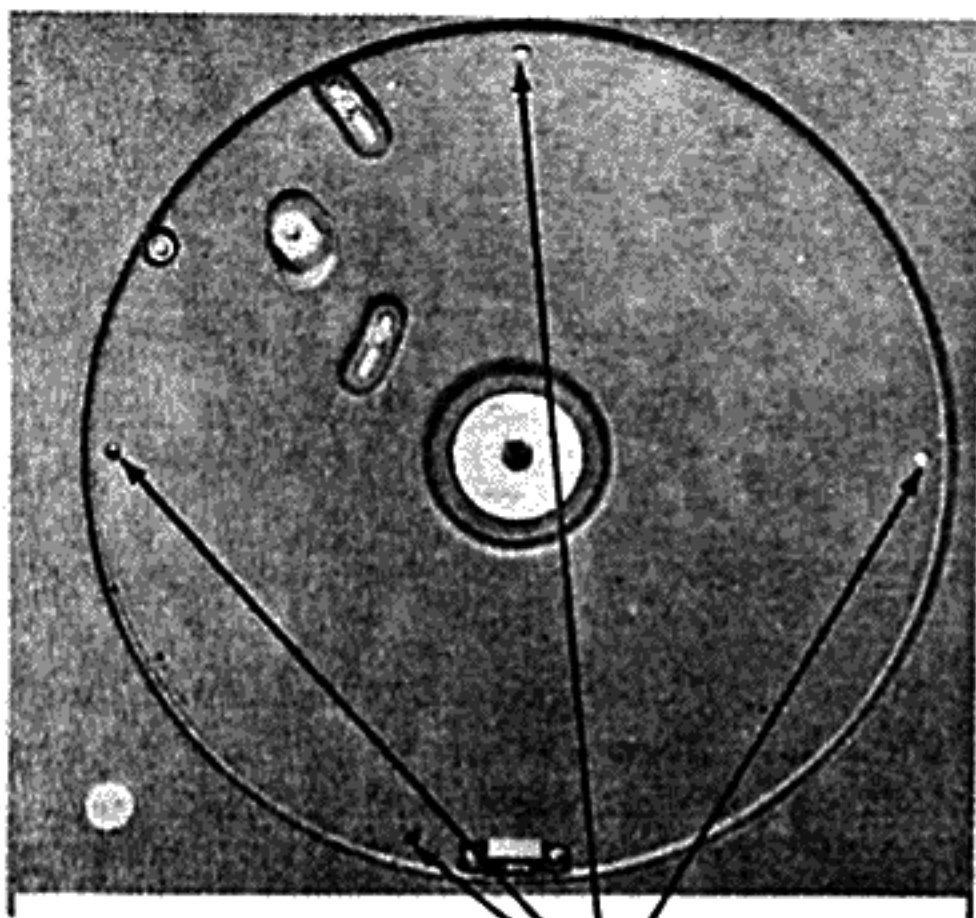
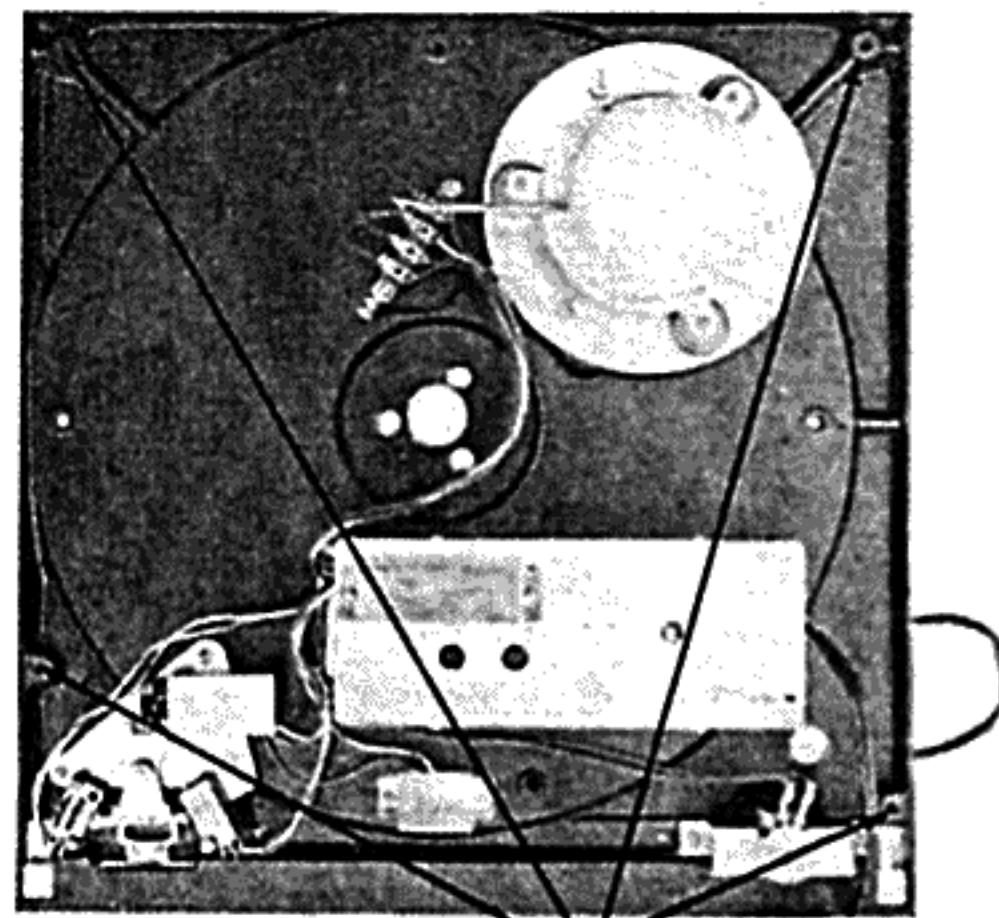

Fig. 6



a (V) wood screws



b (V) machine screws with washers

Fig. 5

Lubrication. Every three months, remove the turntable base and apply 2 or 3 drops of SONY Oil OL-2K to the shaft of the turntable. Reinstall the turntable. Note, motor bearings are completely sealed and never need lubrication.

When lubricating the turntable shaft, inspect the drive belt and the surface of the motor pulley and turntable drive surface. Wipe dust from the belt with a dry cloth. Clean pulley and drive surfaces carefully with a soft cloth moistened with denatured alcohol.

Belt Tension. Drive belt tension has been preset at the factory and need not be reset under normal conditions. If belt tension appears loose, check the length of the belt against a new belt from stock. Replace the belt if it has stretched or if it is cracked or worn.

If belt tension is insufficient with a normal belt, increase belt tension by loosening the three mounting screws for the motor. See Fig. 7. Note, loosen the nuts on the motor side of the mounting screws before the screws are backed out. Reset the position of the motor to move the motor pulley closer to the rim of the turntable well. Tighten the mounting screws, and then tighten the nuts.

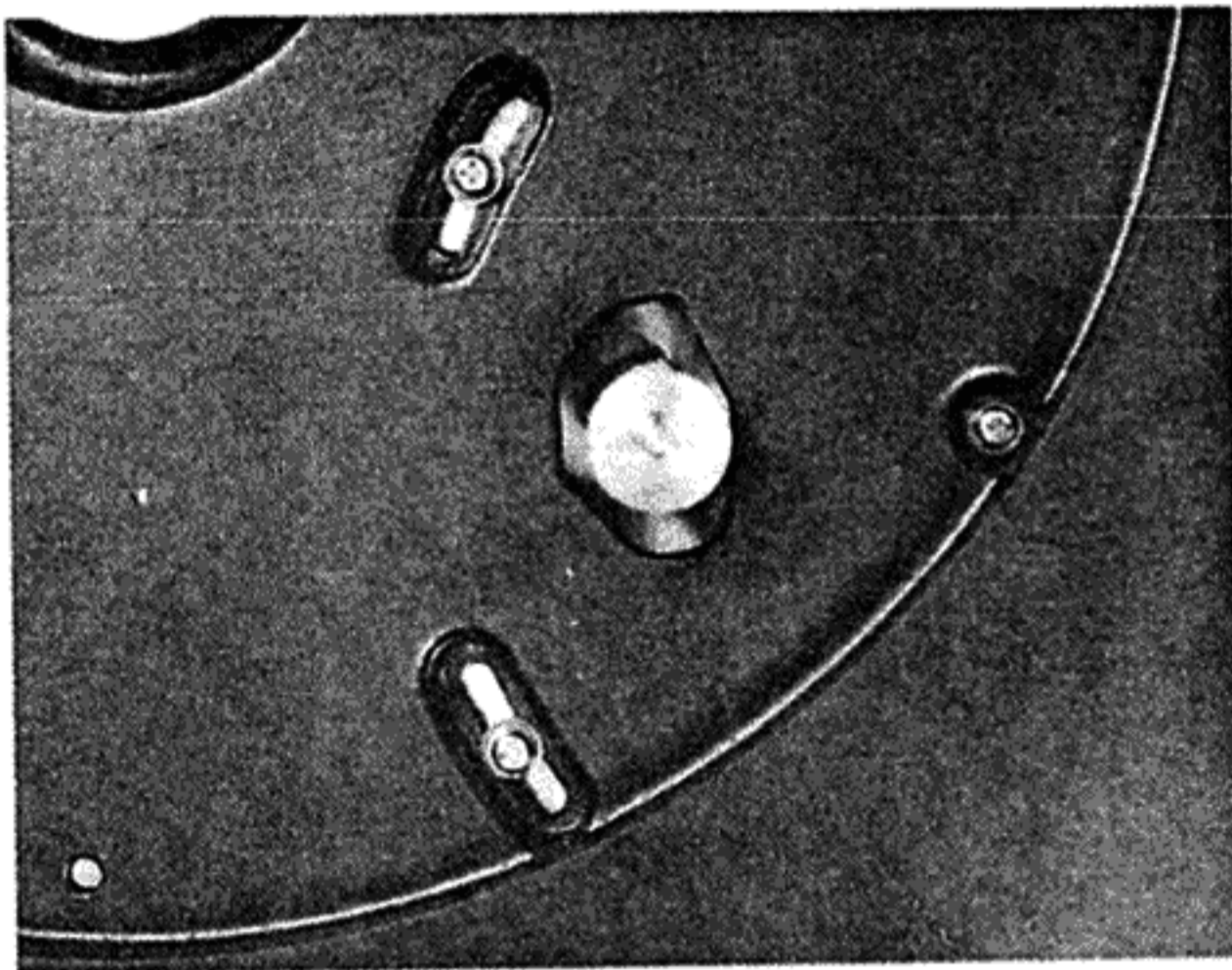

Fig. 7

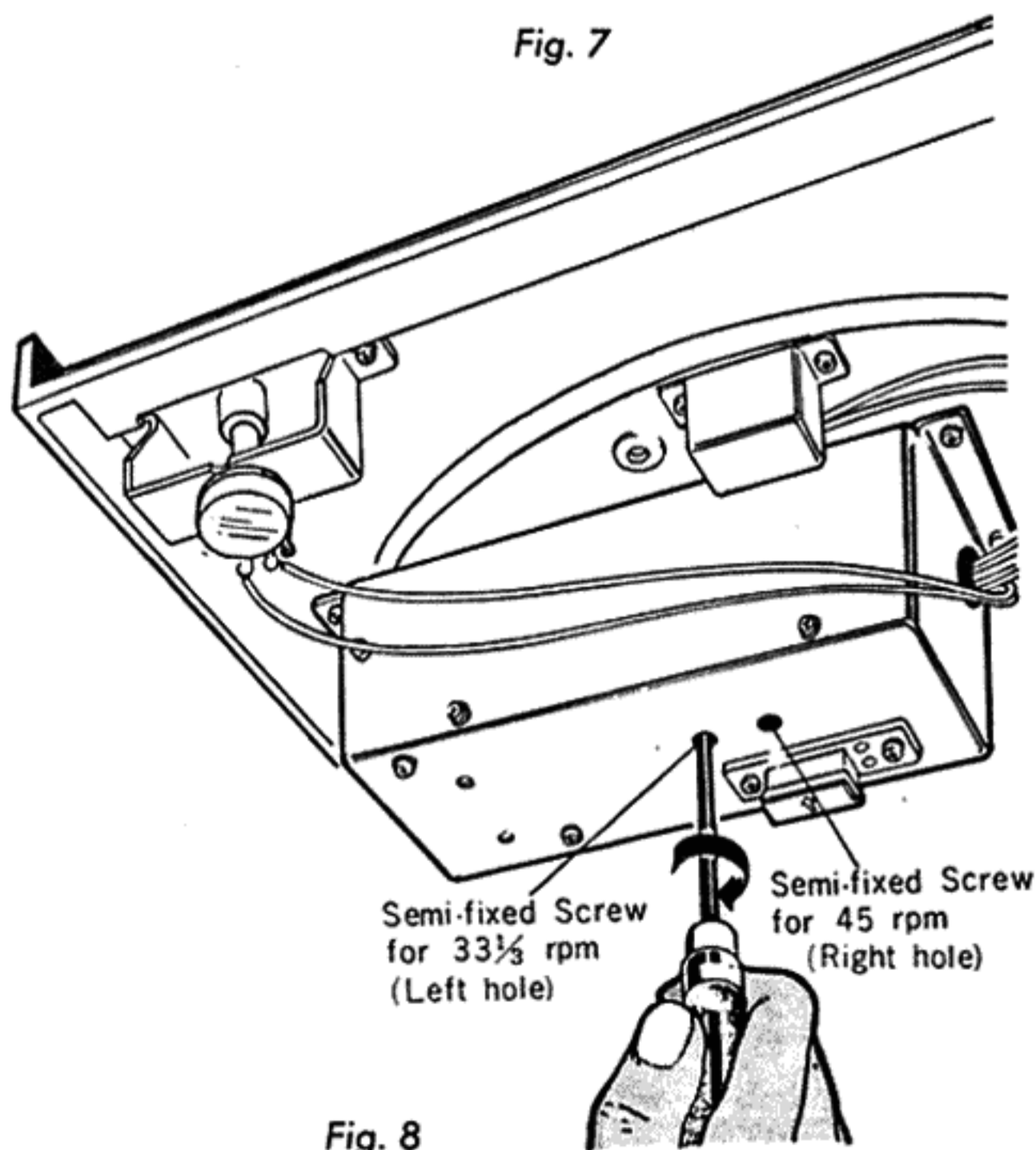

Fig. 8

Speed Controls. Correct operating speed should occur when the front panel speed control is at or near the mid-range setting. If not, adjust the appropriate screwdriver adjustment as shown in Fig. 8. Set the SPEED control to mid position. Place the turntable in the horizontal position. Set the 33-OFF-45 control to the desired speed and turn the appropriate screwdriver adjustment until the strobe indicates correct operating speed.

Thrust Screw Adjustment. The point of the turntable shaft rests on a hardened steel surface at the bottom of the bearing assembly. The steel surface is a cushioned insert housed in the Thrust-Screw that threads into the bearing assembly from the bottom, as shown in Fig. 9. Turntable height is determined by the position of the Thrust Screw.

To adjust turntable height, pull off the cap at the bottom of the bearing assembly, and turn the screw with a large screwdriver. Turn clockwise to raise turntable height. Set the Thrust Screw to make the top surface of the stroboscope skirt just flush with, or slightly below, the surface of the turntable base. Replace the cap at the bottom of the bearing assembly.

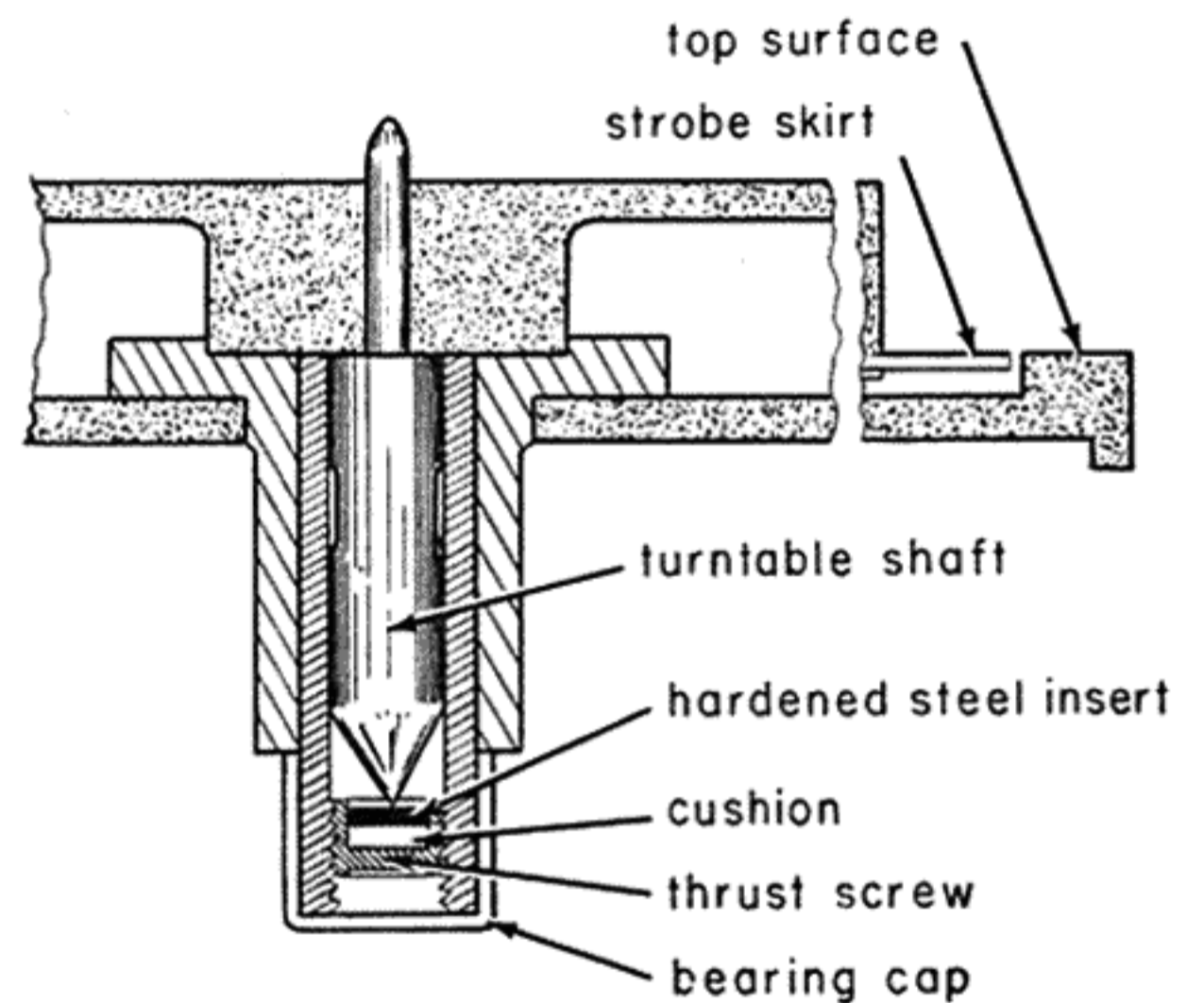

Fig. 9

NOTES

R-F INTERFERENCE

Field reports have indicated servo failure due to very strong r-f interference. In all cases reported, the turntable has been operated at, or very near, an FM transmitter. To eliminate this effect, 0.001- μ F capacitors have been installed between the base and emitter of X1 and X3. Refer to printed-board E and the schematic diagrams. If servo failure due to r-f interference is suspected, check to see that these capacitors have been installed.

TTS-3000 MOUNTING BASES

Two mounting bases are available as accessories for the TTS-3000. These are the TAC-2 and the TAC-3. The bases are similar except for the long dimension and the locations of the mounting holes for the tone arm. The TAC-2 accepts the 12" tone arm, PUA-237; the TAC-3 accepts the 16" tone arm, PUA-286.

Installation. The TTS-3000 can be secured to the mounting base by means of four wood screws as shown in Fig. 5a. These screws pass through the base of TTS-3000 into the wooden mounting base. An alternative system is to insert machine screws into the underside of the TTS-3000 base from the bottom of the mounting base as shown in Fig. 5b. Both wood screws and machine screws are supplied with the TTS-3000.

The factory-assembled system, PS-2000, employs the TTS-3000 and the TAC-2 mounting base. In this system,

wood screws are used to secure the TTS-3000 to the mounting base.

Suspension System. Acoustic isolation between the turntable and the surroundings is provided by the feet of the mounting base. The feet support the mounting base by means of acoustically damped springs.

Figure 10 shows how the feet are fastened to the mounting base. Spring tension is adjustable at each of the feet by means of a threaded rod at the top of each foot assembly. Tension is factory adjusted so that the base floats freely.

When replacing a foot assembly, measure the overall height of the original unit and set the pressure adjusting screw on the replacement to produce the same overall height.

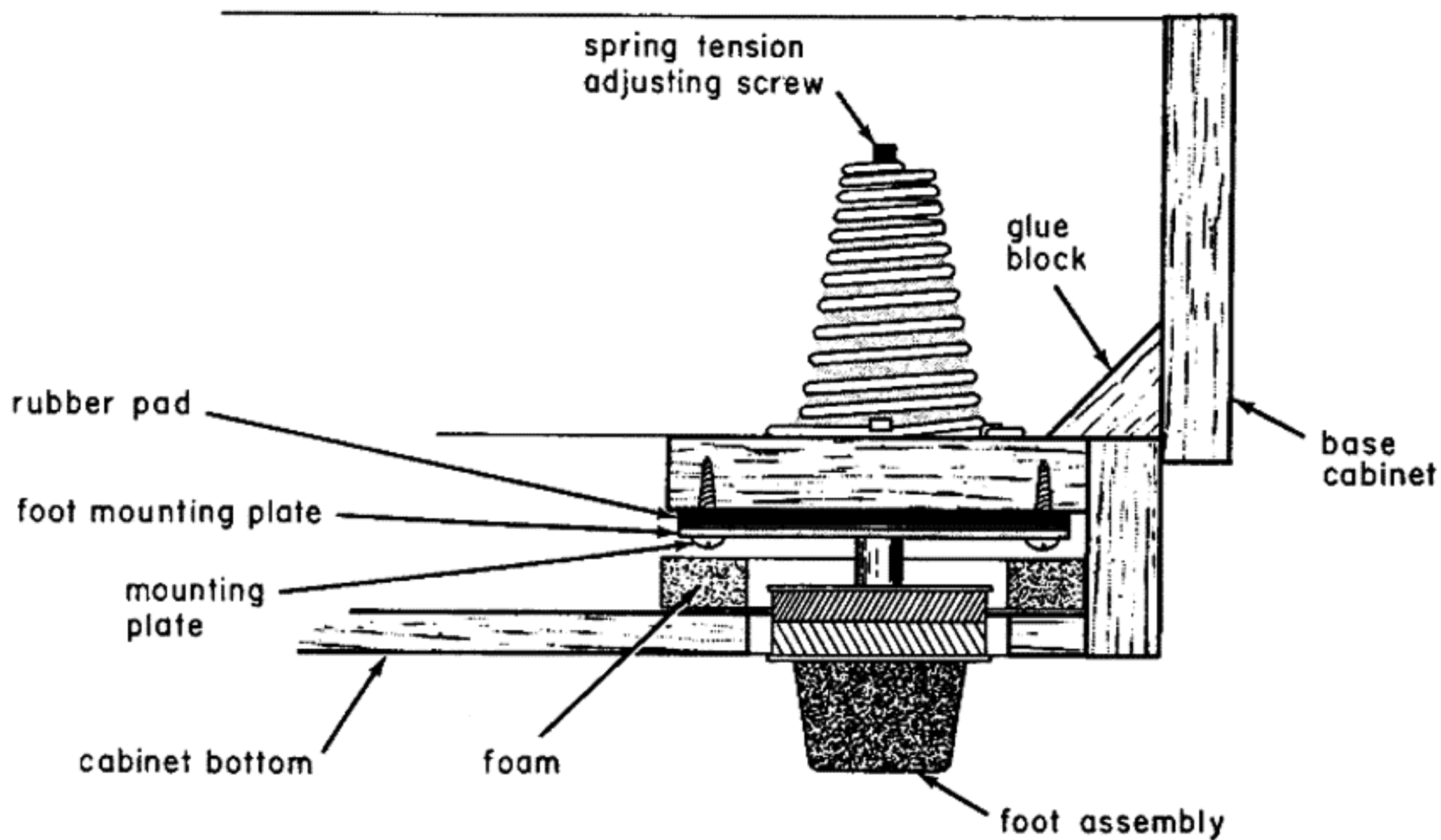
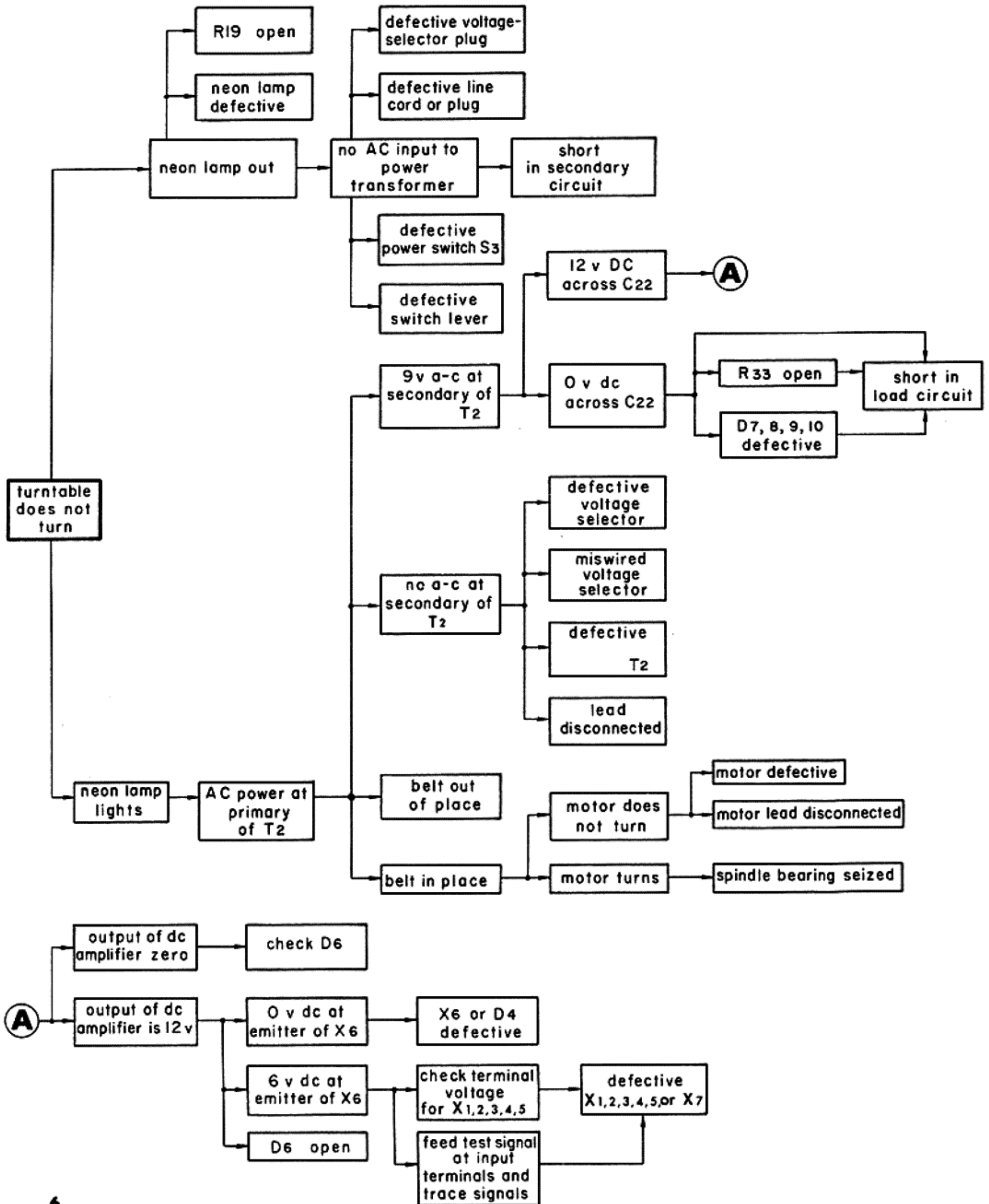

Fig. 10

TROUBLESHOOTING CHARTS

1. TURNTABLE DOES NOT TURN



2. TURNTABLE TURNS TOO FAST

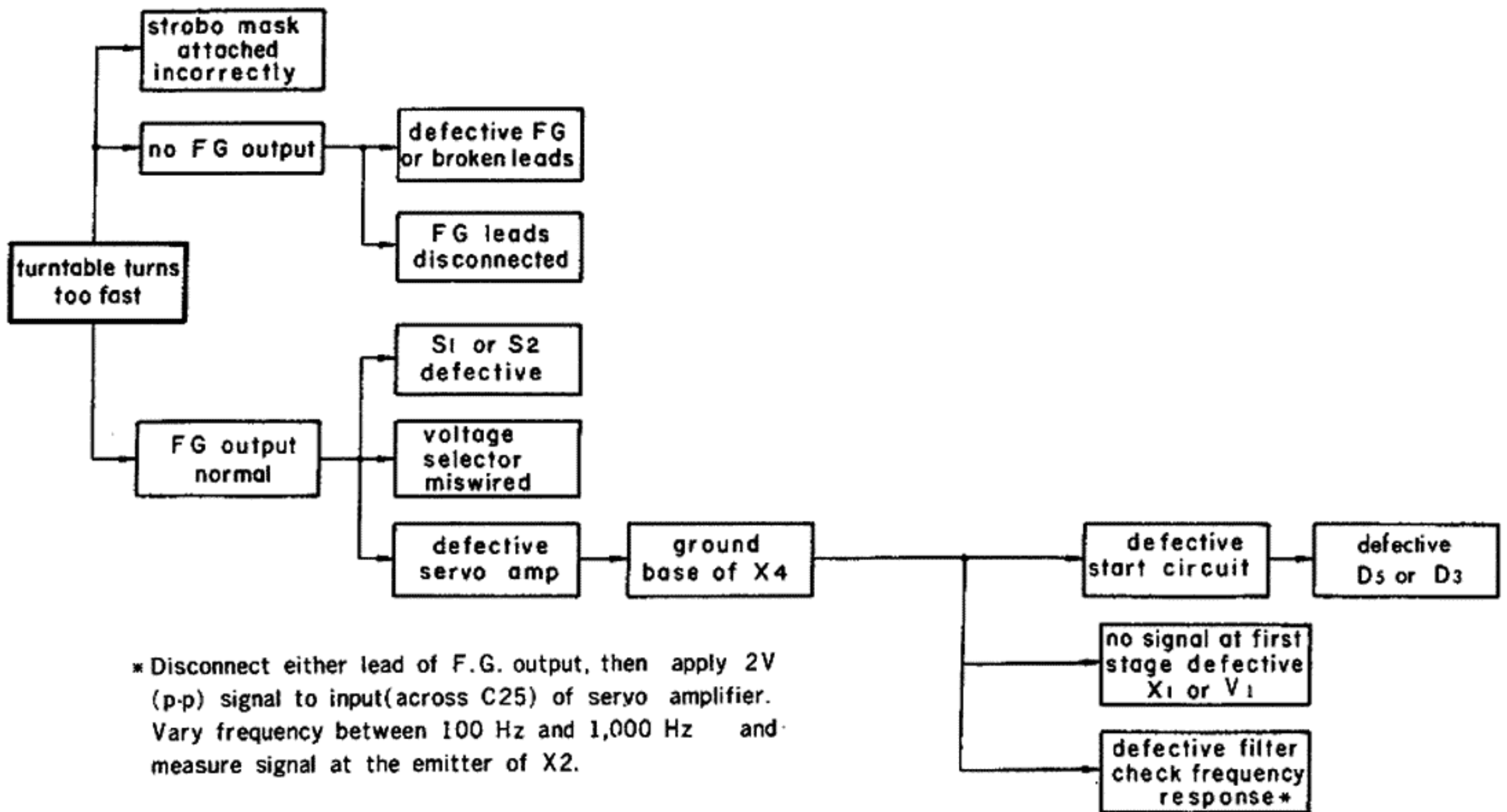

3. TURNTABLE SPEED SLIGHTLY HIGH (33 1/3 +)

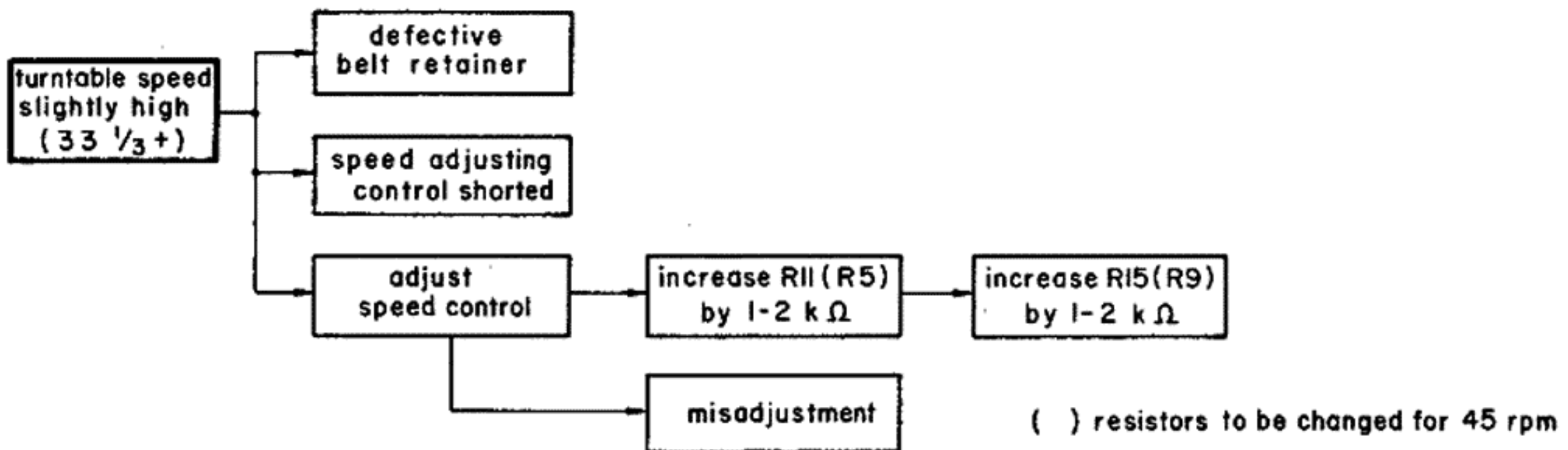

4. TURNTABLE TURNS TOO SLOWLY

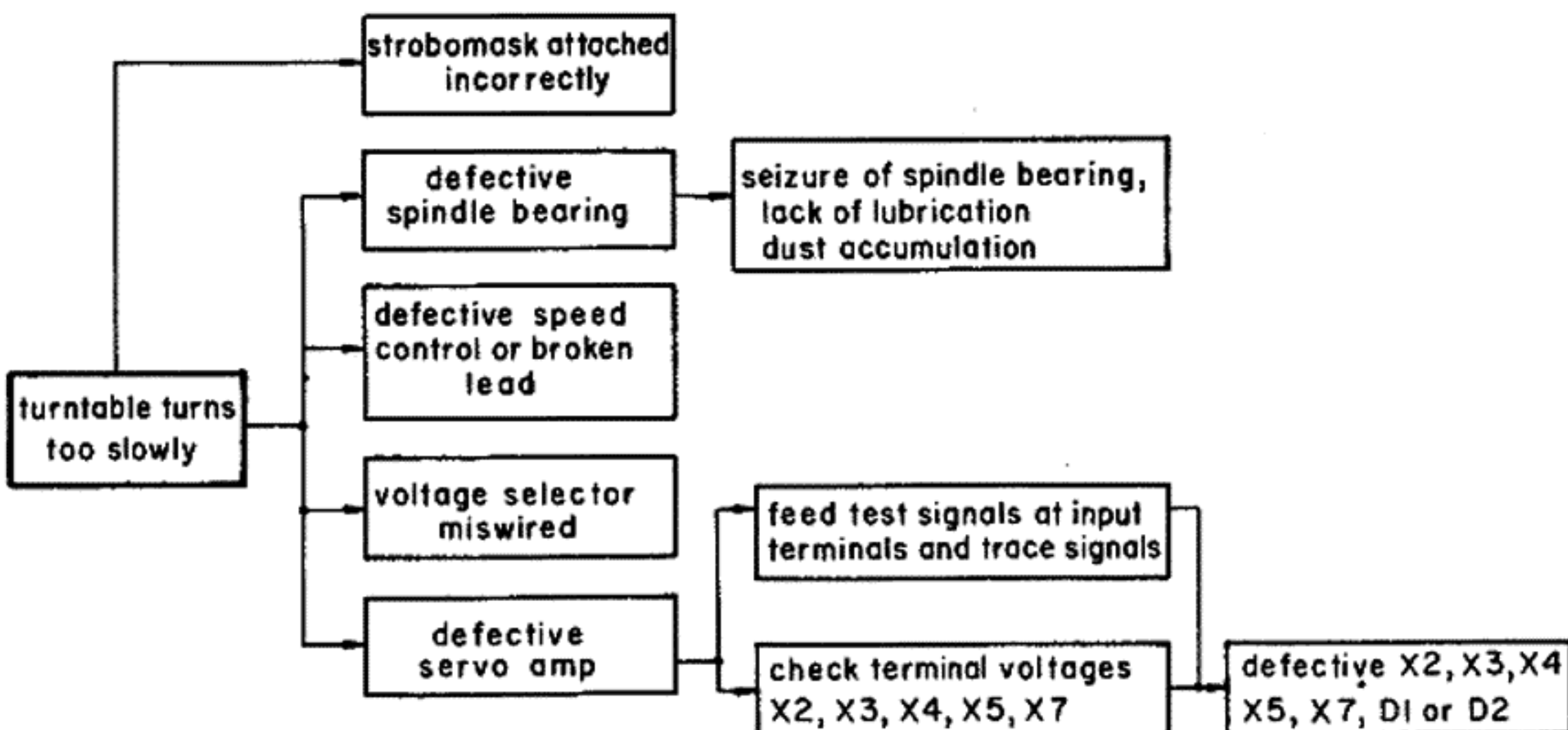

5. TURNTABLE SPEED SLIGHTLY LOW ($-33 \frac{1}{3}$)

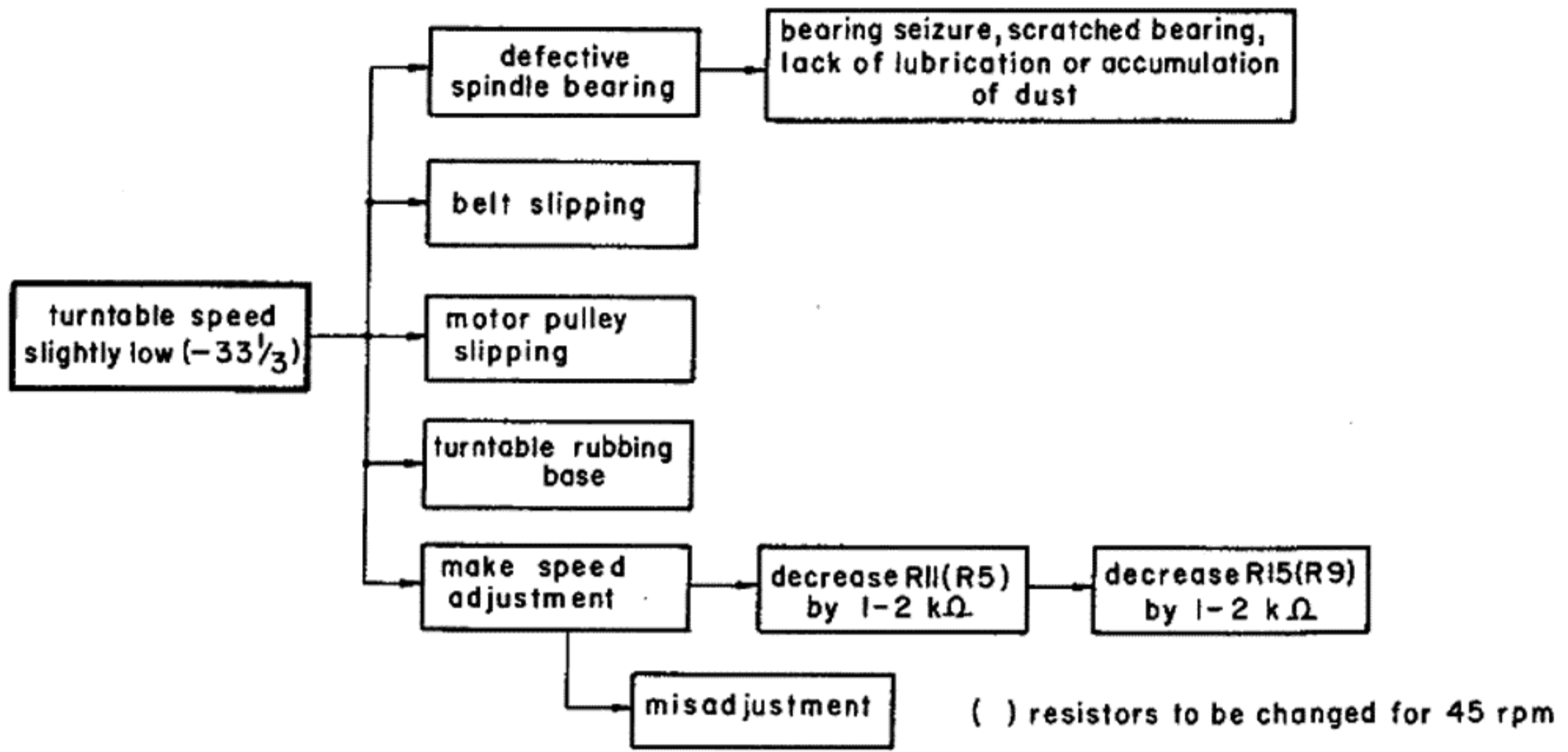

6. EXCESSIVE FLUTTER AND WOW

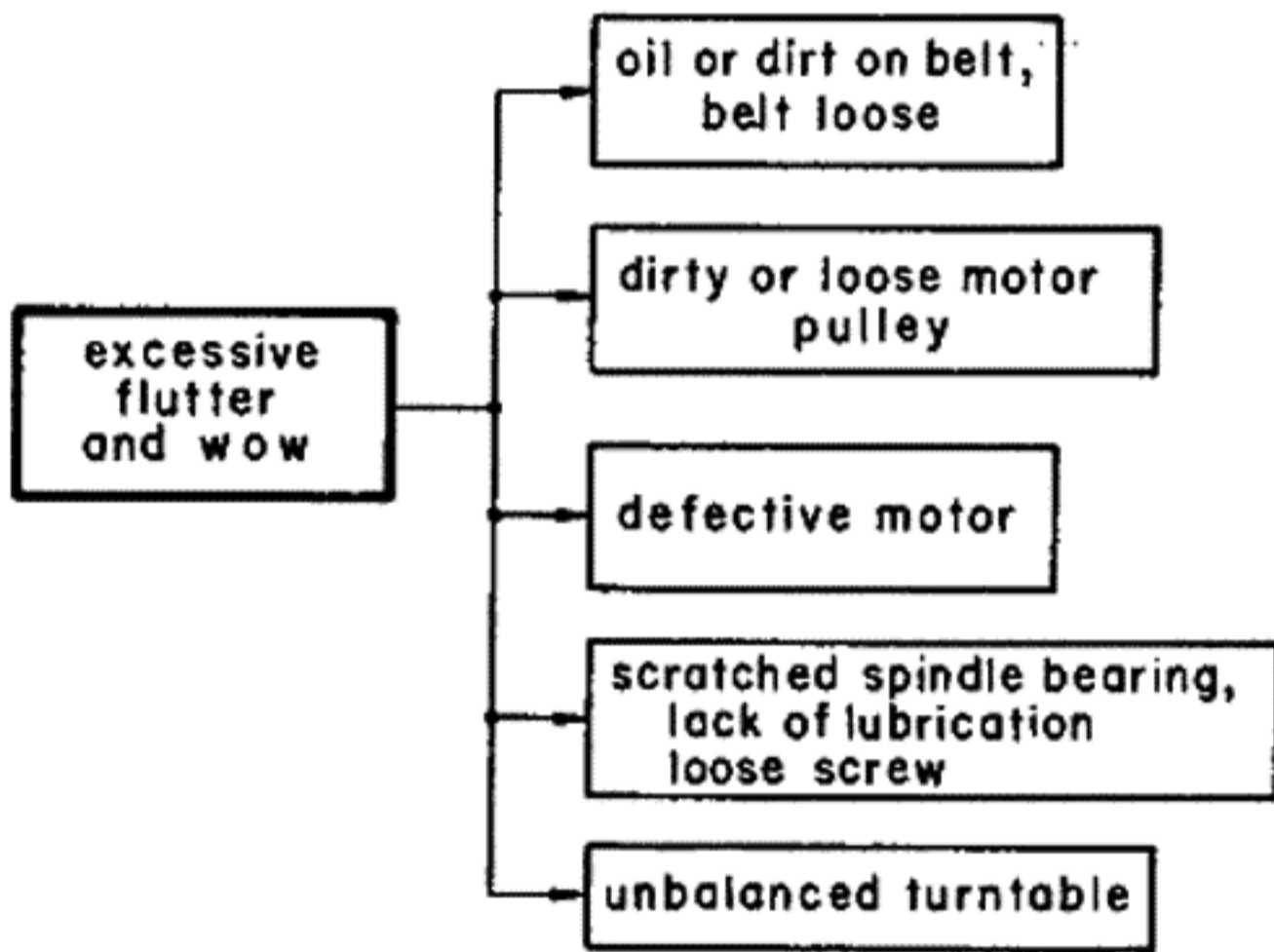

7. NOISE

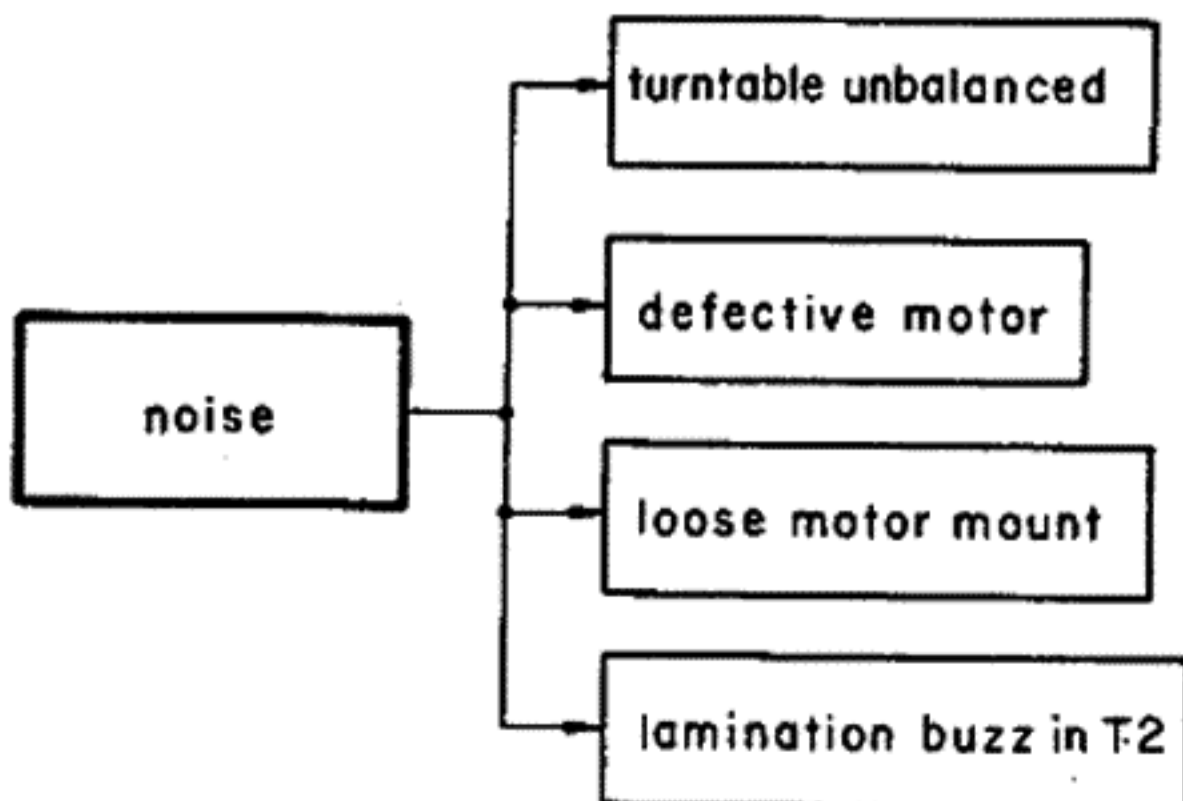

TTS-3000 CIRCUIT SCHEMATIC

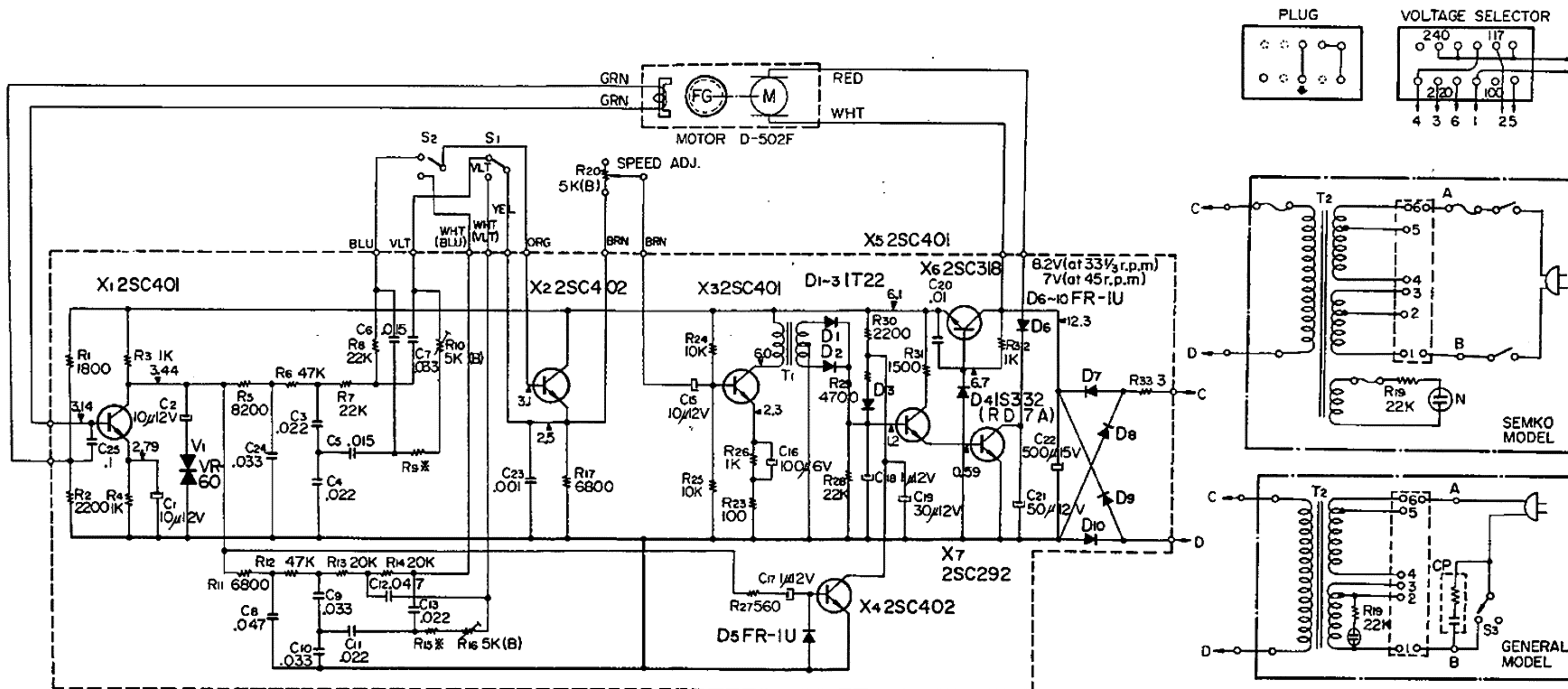

* : To be adjusted

All d-c voltages are measured by VTVM at exactly synchronized state with 33-1/3 r.p.m.

TTS-3000 MOUNTING DIAGRAM

Servo Amplifier
Conductor Side—

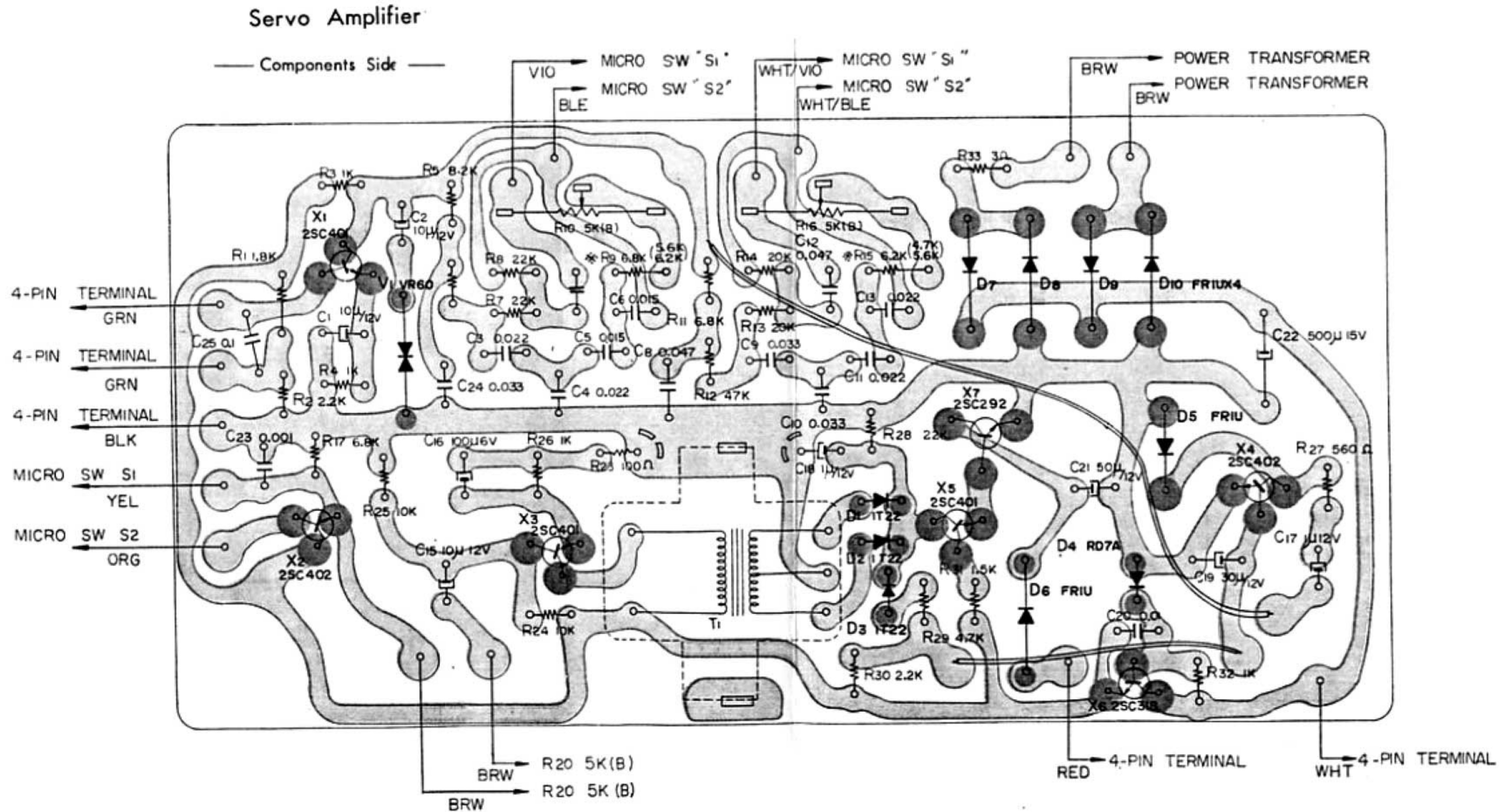

Note: * To be adjusted.

Servo Amplifier

— Component Side —

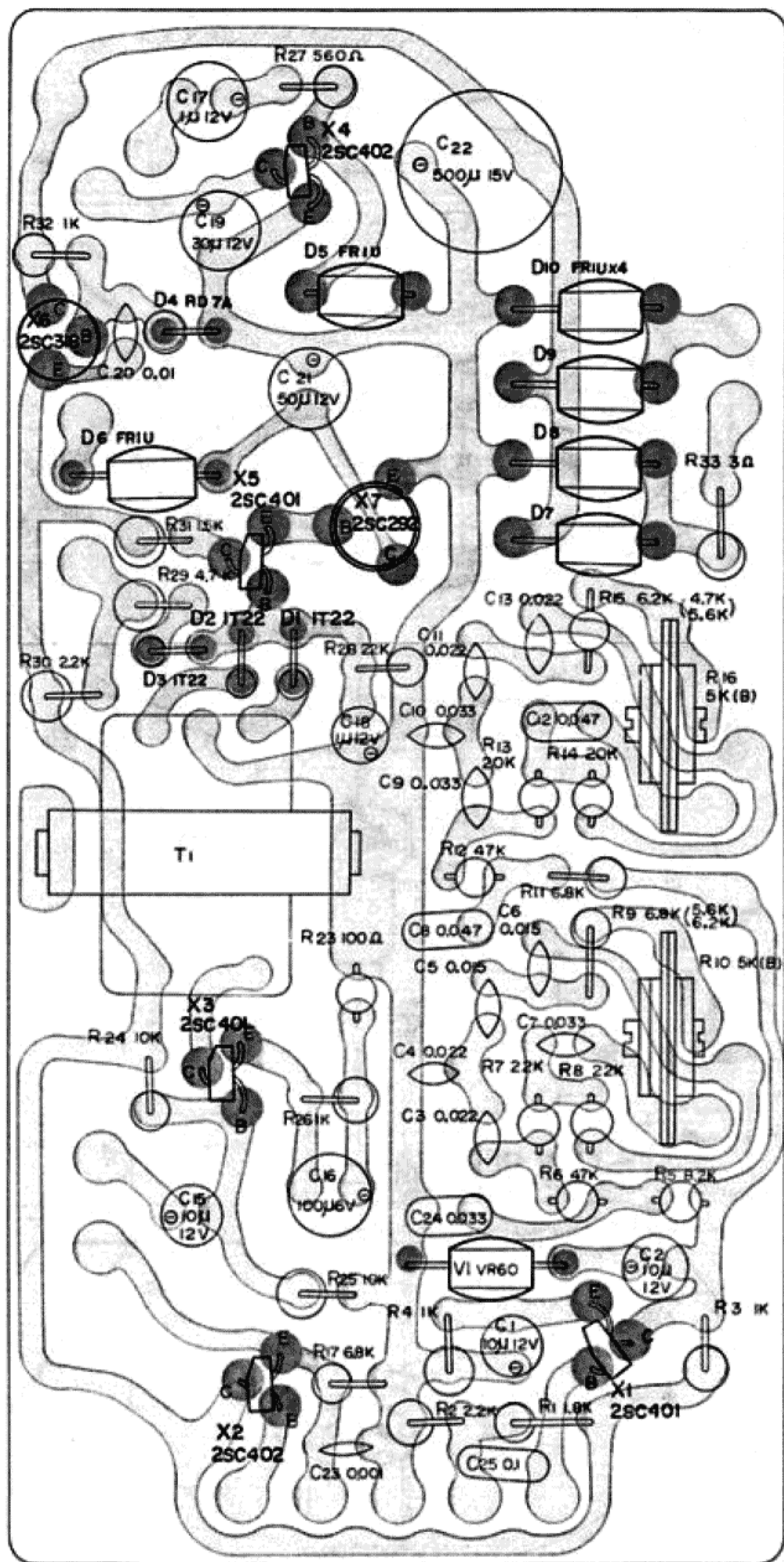

Exploded Diagram (1)

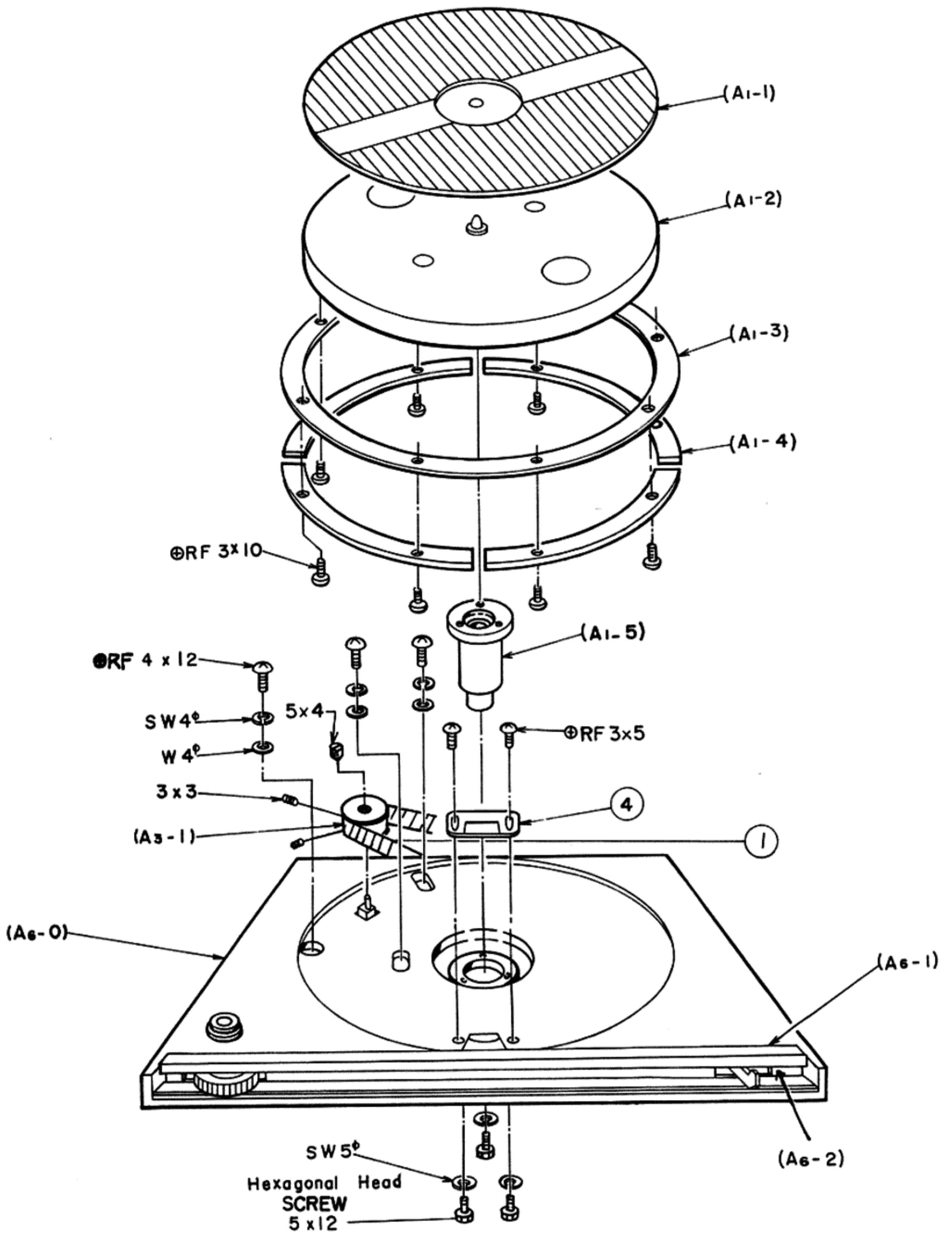

Exploded Diagram (2)

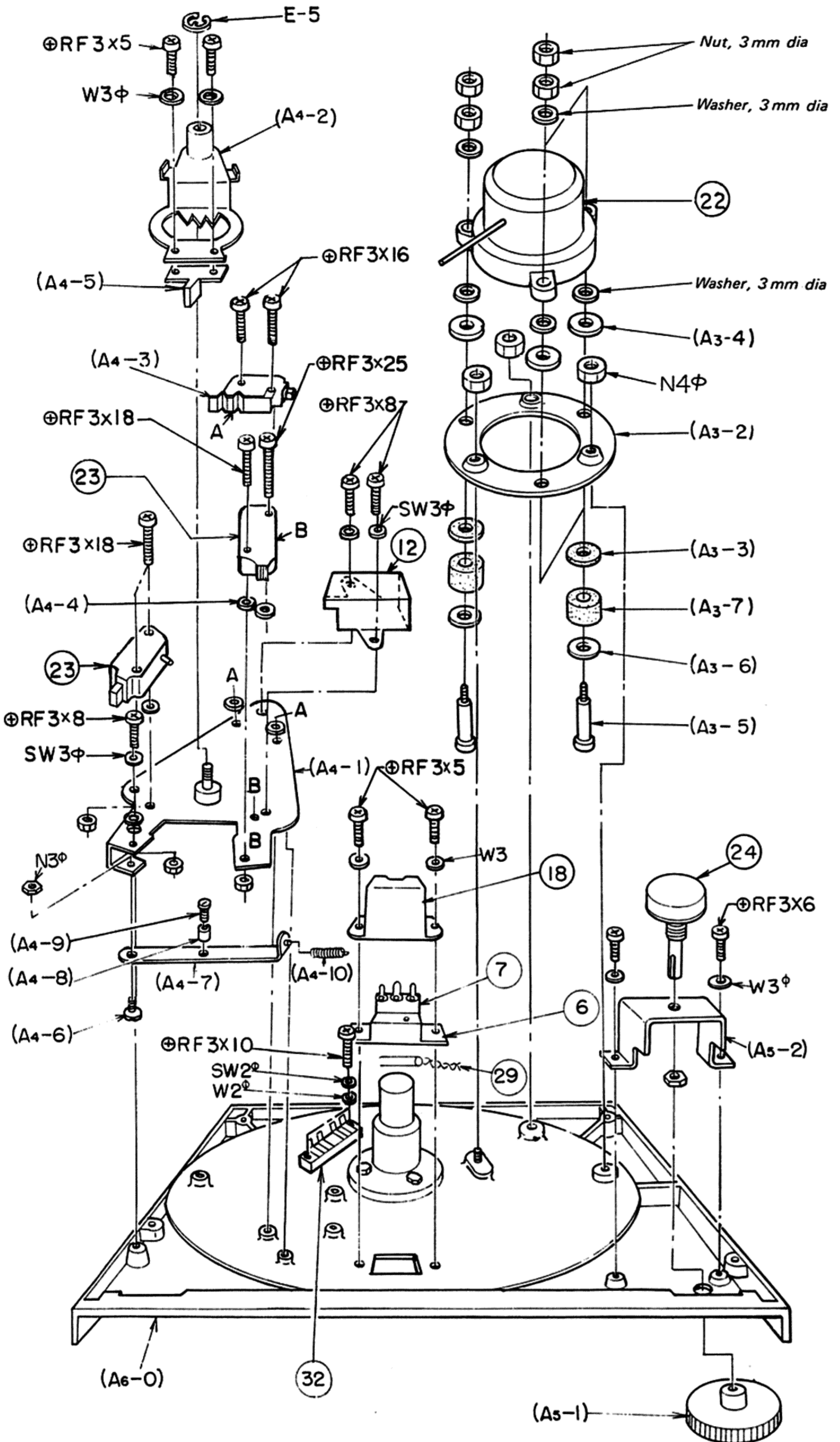

Exploded Diagram (3)

