

SONY® SERVO TURNTABLE TTS-3000



OWNER'S INSTRUCTION MANUAL

SONY®

SERVO TURNTABLE TTS-3000

SONY proudly presents this high precision turntable. This SONY servo-controlled turntable TTS-3000 incorporates a DC servo motor furnished with a frequency generator as its speed control signal source, thus succeeding in eliminating vibration and noise which are transmitted from the motor to the turntable.

This turntable has been carefully adjusted and balanced with several precision devices for excellent performance.

Therefore to obtain optimum performance and enjoyment from this turntable, carefully read this instruction manual.

Main Features

- 1) Revolutionary servo-controlled system: no vibration and no noise with the very slow speed self-servo DC motor.
- 2) Exceptionally low wow and flutter: less than 0.05%.
- 3) High signal-to-noise ratio: over 60 db (NAB Standard).
- 4) Speed is not influenced at all by AC power frequency: the self-servo system perfectly controls the DC driving motor.
- 5) Electrically controlled speed selection and adjustments.



*The photograph shows the combination of the SONY SERVO TURNTABLE TTS-3000, the SONY PRECISION TONE ARM PUA-286, and the SONY STEREO CARTRIDGE VC-8E.

Location of Controls

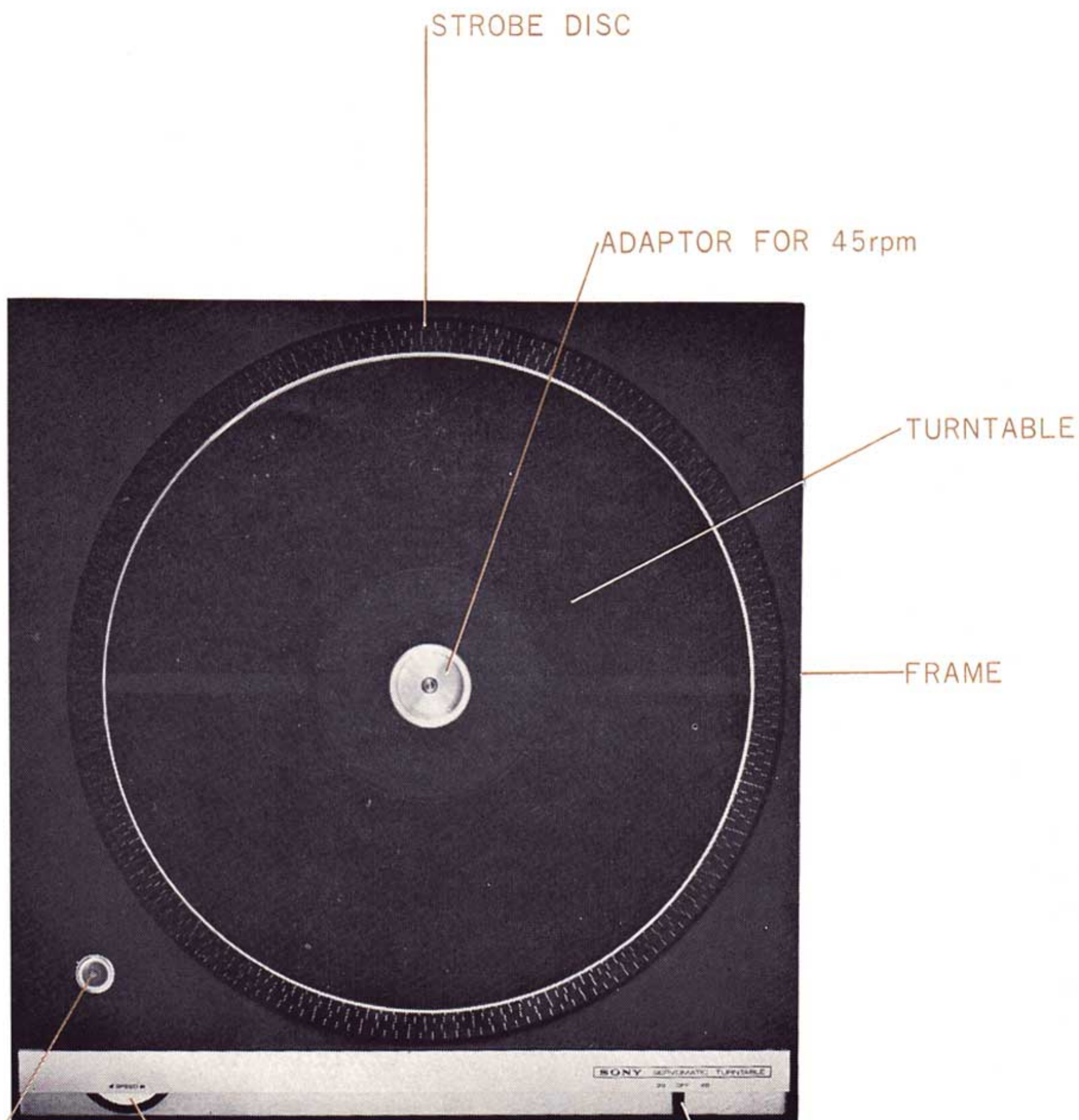

LEVEL

Use the level to make sure that the turntable is in a substantially level position.

SPEED CONTROL KNOB

When the stripes of the strobe disc do not cease, slowly turn the knob in the opposite direction from the rotating direction of the strobe disc until the stripes cease. Then correct speed is achieved.

SPEED SELECTION LEVER

Set the lever to the left (33 $\frac{1}{3}$ rpm) or to the right (45 rpm) according to the speed of the disc. In the OFF position, the power is turned OFF.

Installation

Unpack and remove the contents in the following order, then install as illustrated.

- ① First, place the frame.
- ② Lubricate the frame center hole with the supplied SONY OIL OL-2K.
- ③ Second, put the enclosed rubber belt around the inside circle located at the back of the turntable. Insert both your thumbs into the two holes with one of the thumbs inside the rubber belt as illustrated. Then place the turntable carefully on the frame and simultaneously thread the rubber belt around the motor pulley.
- ④ Put the rubber mat on the turntable. If necessary, use the supplied adaptor for 45 rpm.

Notes for installation

- * When installing the frame on a motor board, refer to the enclosed Mounting Pattern.
- * Handle the outer strobe disc of the turntable with care.
- * Make sure that the motor and shaft do not touch the case since the motor is isolated from the frame with a rubber cushion.

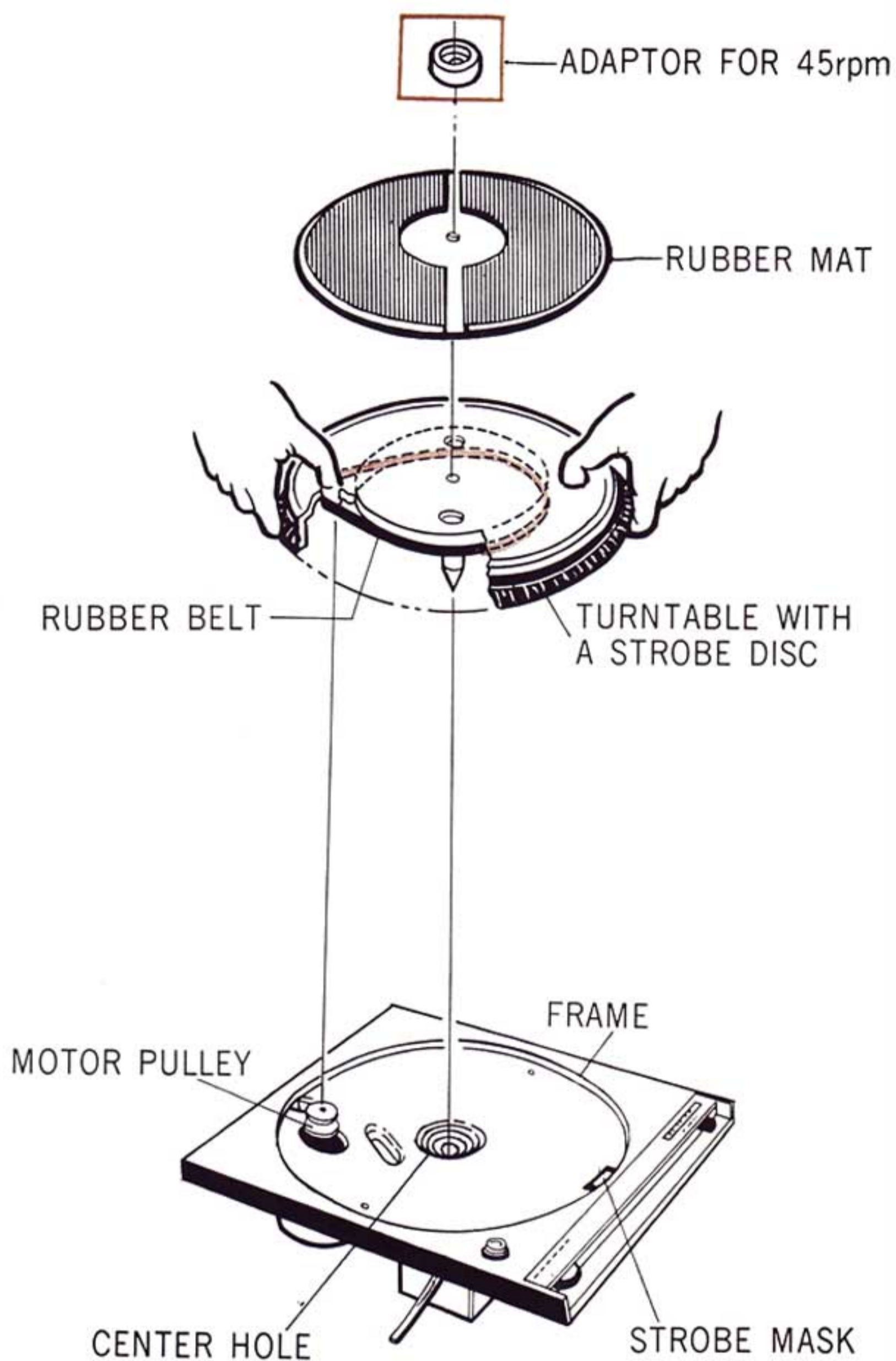

Fine Speed Control

In either 33½ rpm or 45 rpm, the speed control is designed to be finely adjusted in approximately the middle section of the speed control knob. However if it should happen that the correct speed can not be obtained by the knob, adjust the speed to either 33½ (left hole) or 45 rpm (right hole), as Illustrated, by slowly turning the semi-fixed screw control located on the bottom of the amplifier case.

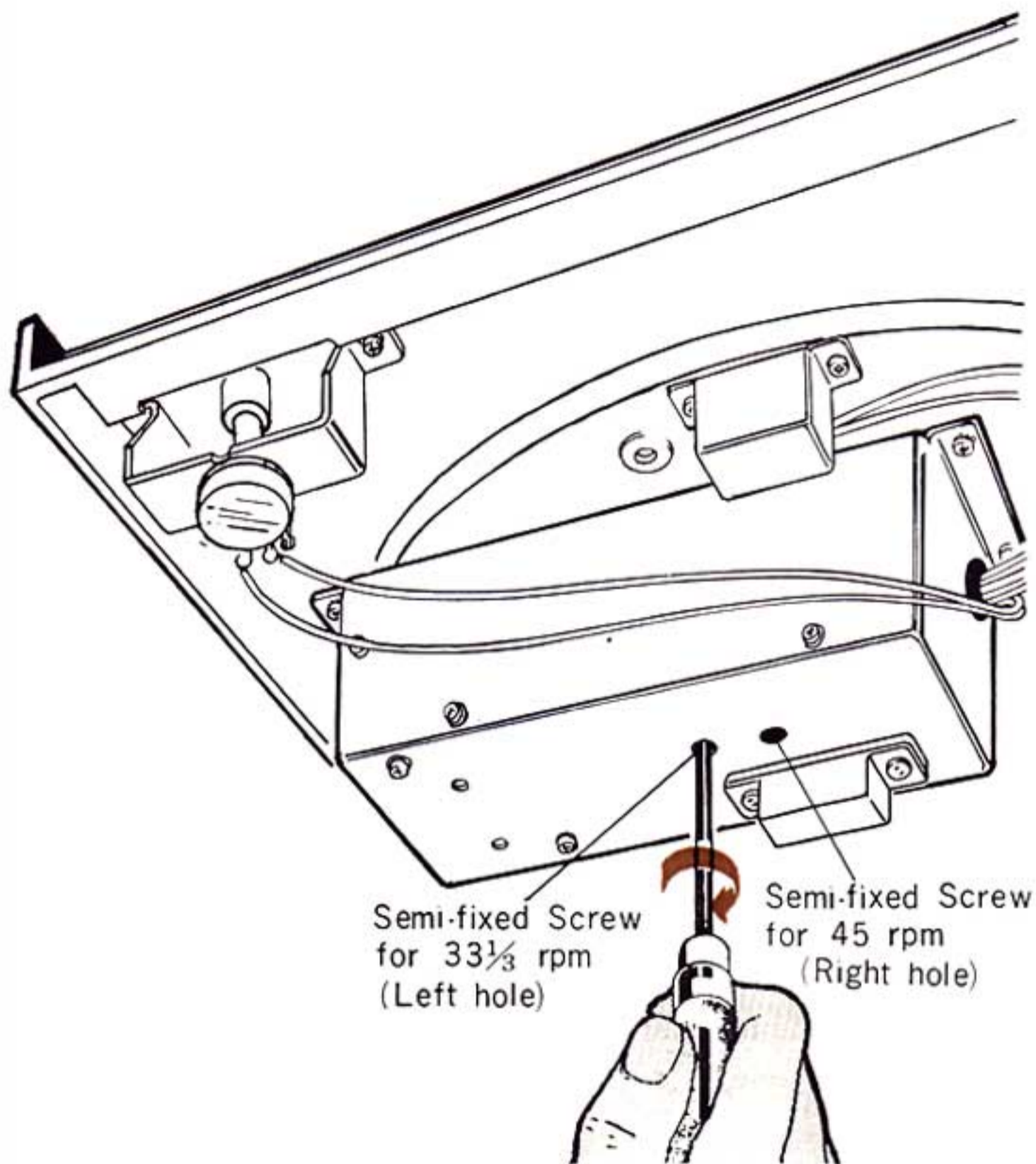

The Principle of "Servo-controlled" Systems

The servo motor used in the TTS-3000 consists of a DC motor and a Frequency Generator (F.G.). The F.G. amplified by an AC amplifier passes through the limiter to eliminate level changes and is converted into DC output according to its frequency. This output is amplified by the DC amplifier and is supplied to the motor.

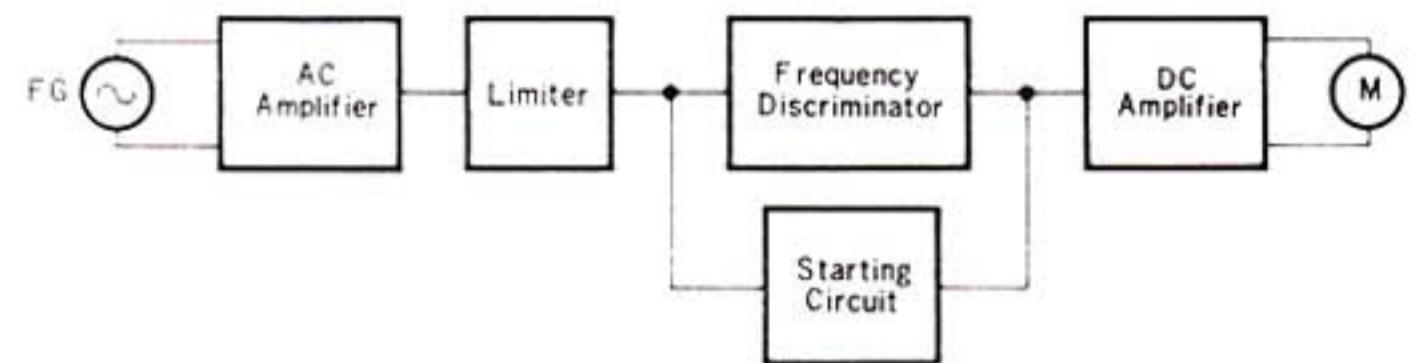

The frequency changes in the F.G.—the changes of the speed of the motor—will change the terminal voltage of the motor with the Frequency Discriminator.

The graph indicated below shows their relation. If the rotation of the motor is accelerated (or slow down) because of a certain external cause, the frequency f_0 of the F.G. moves by Δf to the left (or to the right). Then, the terminal voltage v_0 goes down (or up) by Δv and the motor speed is lowered (accelerated) and consequently the frequency generated by the F.G. returns to f_0 . Thus servo-controlled system keeps the "equilibrium condition" at f_0 and the motor operates in constant speed.

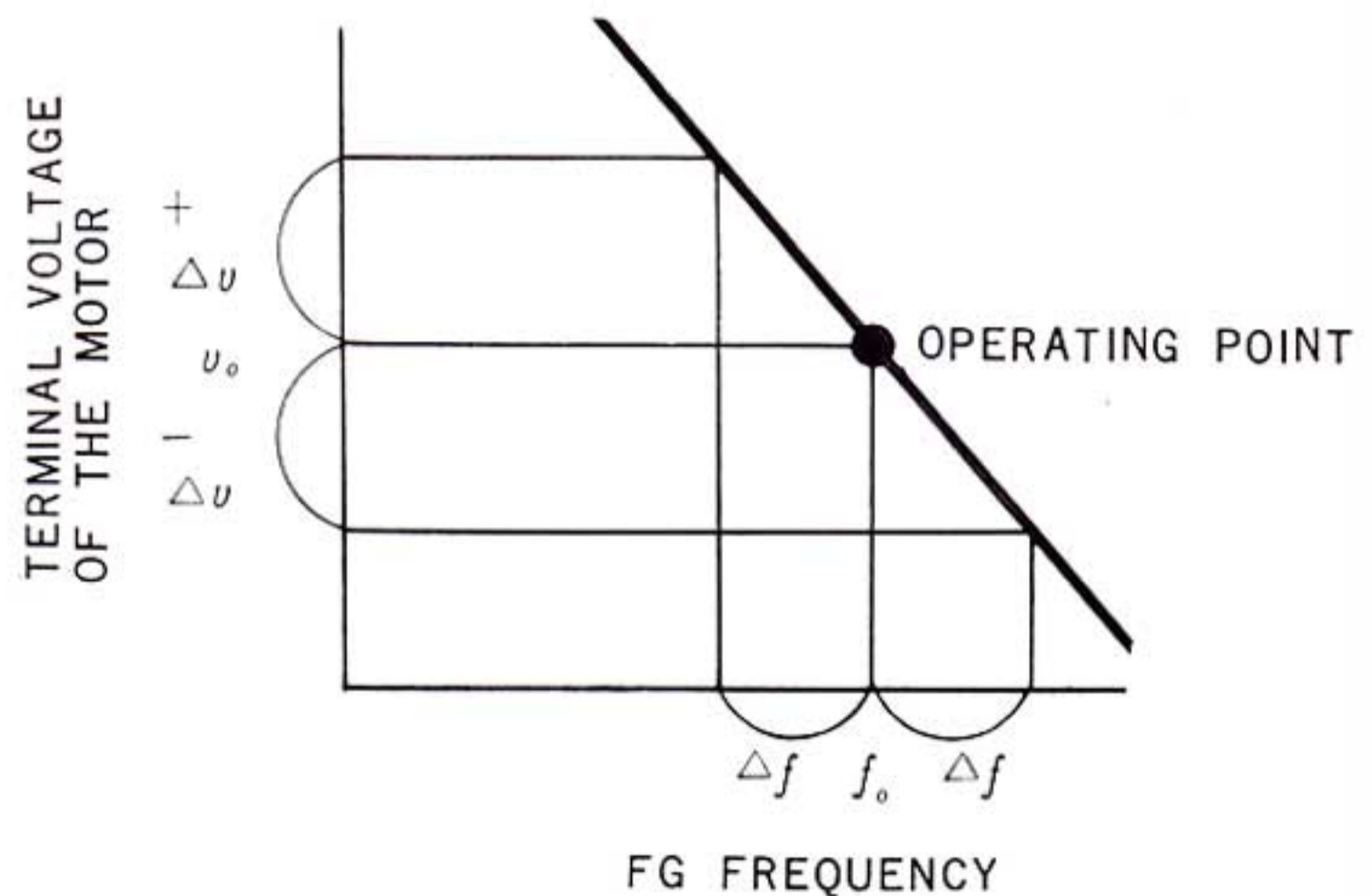

Inspection and Lubrication

- 1) Occasionally remove any dust accumulated on the rubber belt with a dry cloth.
Wipe the motor pulley and turntable with a cloth dampened with denatured alcohol or carbon tetrachloride. Otherwise wow and flutter may be caused.
- 2) Lubricate with the supplied SONY OIL OL-2K into the axis hole of the frame every 3 months. A few drops of oil are sufficient in quantity.
The motor needs no lubrication.

Specifications

2 Speeds: 33½ rpm and 45 rpm.
Speed Control Range: $\pm 5\%$
Start-up time: within 1 sec.
Wow and flutter: less than 0.05% rms
S/N: Over 60 db (NAB Standard)
Turntable up and down motion: within ± 0.05 mm
Power requirements: 117 V AC 60 c/s
Power consumption: 3 W (4 VA)
Turntable: 12", Aluminium-diecasted, 3 lb 5 oz
Weight: about 12 lb 12 oz
Dimensions: 14-9/16"(W) \times 5-1/8"(H) \times 15"(D)

Optional Accessories

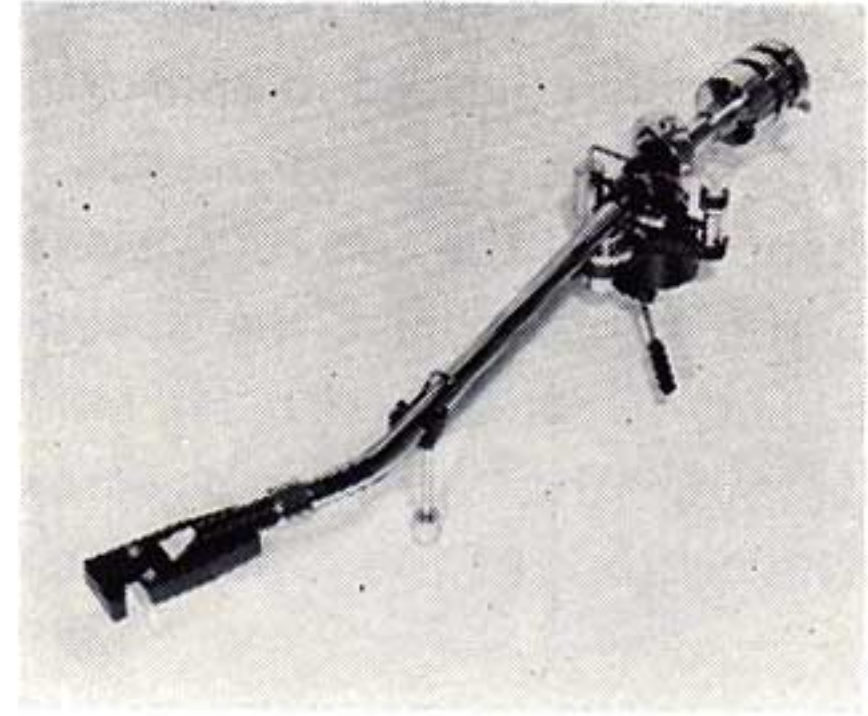

PRECISION TONE ARM PUA-237, PUA-286

Perfect inside force compensator and complete lateral balancer are incorporated.

	PUA-237	PUA-286
Pivot to stylus tip:	9-11/32"	11-1/4"
Tracking error:	$\pm 1^{\circ}44'$	$\pm 1^{\circ}24'$
Stylus force adjustment:	0~3 gr.	0~3 gr.



STEREO CARTRIDGE VC-8E

High compliance moving coil cartridge with an elliptical diamond stylus.

Frequency response: 10~25,000 c/s
Output voltage: 4 mV ± 2 db (1000 c/s, 5 cm/sec)
Compliance: 30×10^{-6} cm/dyne
Stylus tip radius: 0.2 \times 0.8 mil elliptical, diamond
Stylus force: 0.5~2 gr.

