

The home of the turntable

THE VINYL **ENGINE**®

For more turntable manuals and setup information
please visit www.vinylengine.com

SONY®



OWNER'S INSTRUCTION MANUAL

SONY®

PRECISION TONE ARM

PUA-237 • PUA-286

Both these SONY Tone Arms will give optimum performance to your sound system.

True precision in the manufacturing process, excellent design that borders on the revolutionary and SONY craftsmanship combine to provide a truly excellent component for your sound system.

These Tone Arms were designed with the SONY TTS-3000 servomatic turntable and SONY VC-8E moving coil cartridge in mind. Of course, they will provide unparalleled performance with any of today's fine turntables and high compliance cartridges. The amazing stability of these arms is possible by the proper coordination of several outstanding features.

• POSITIVE ANTI-SKATING DEVICE

SONY's advanced technology has developed an exclusive anti-skate compensation device. Now, at last, the inside thrust force is definitely cancelled at every position on the record.

• INDEPENDENT BALANCER SYSTEM

The lateral balance of the tone arm operates completely independent of the counter weight of the stylus force adjustment. Therefore, you may adjust stylus force repeatedly with no effect on the lateral balance of the arm.

• INTEGRATED LEAD-IN GROOVE SELECTOR

The four positions provided permit easy selection for the first groove lead-in on 12" (30 cm), 10" (25 cm) and 7" (17 cm) records plus a position which leaves the arm in free motion.

• INTEGRAL CUEING

This device employs a silicone-damped piston which provides easy placing of the stylus onto any groove of the record.

• SIMPLE STYLUS FORCE GAUGE

Simply slide the stylus force weight to the desired force and you can see the weight selected.

- Interchangeable tone arm head accepts any standard cartridge.
- Precision micro-ball bearings provide the closest thing to frictionless arm-pivot suspension.
- Correct stylus overhang is obtained by a simple cartridge head adjustment.

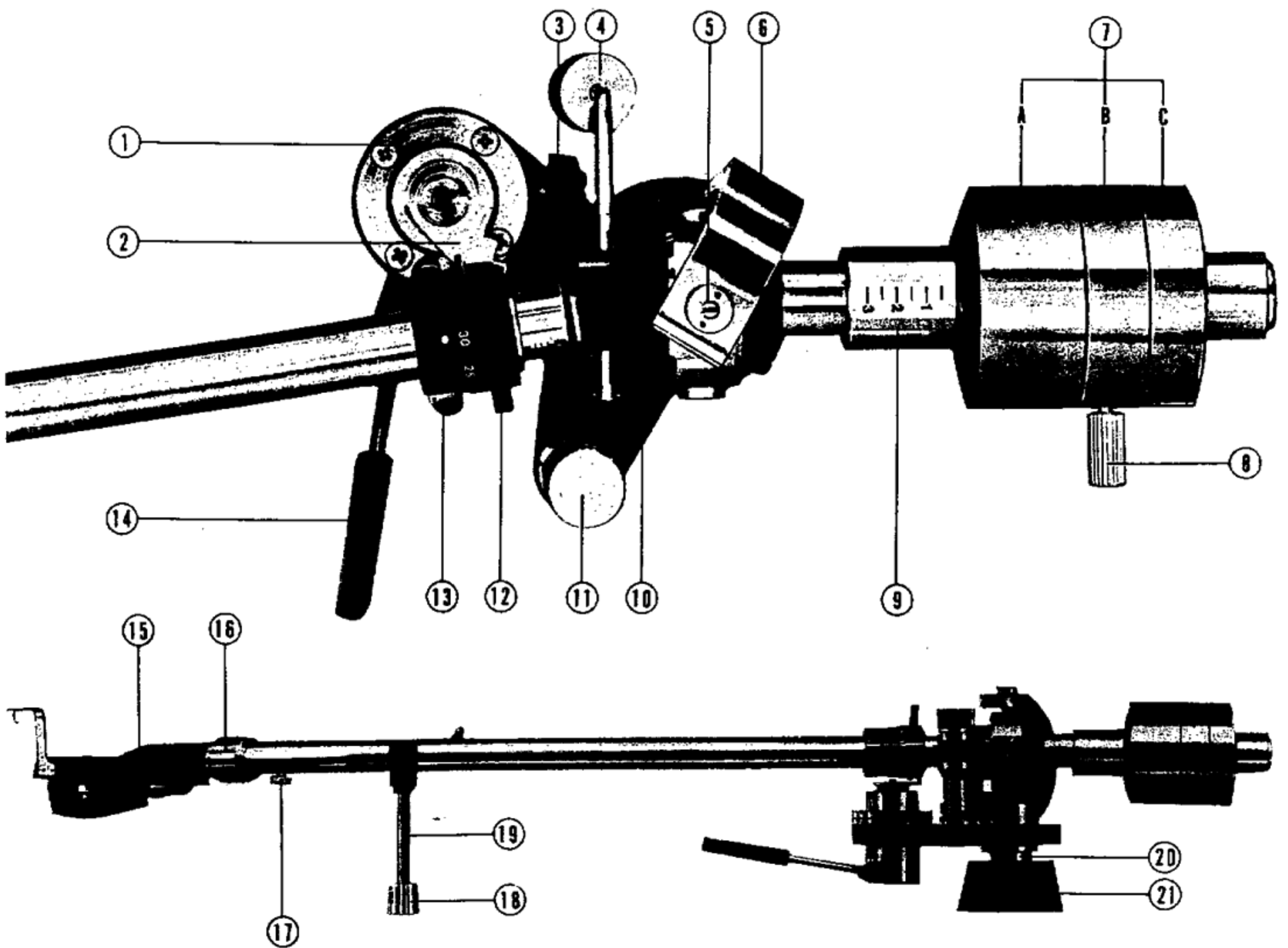

- 1. Lift cylinder
- 2. Drop point preset cam
- 3. Bias cam
- 4. Lateral balancer weight
- 5. Arm pivot
- 6. Gimbals support
- 7. Counter weight assembly
 - A. Stylus force weight
 - B. Main weight
 - C. Vernier weight
- 8. Knurled screw
- 9. Stylus force gauge
- 10. Cueing deck
- 11. Bias compensator knob
- 12. Drop point selector
- 13. Cueing track
- 14. Cueing lever
- 15. Shell
- 16. Locking collar
- 17. Cartridge angle adjustment screw
- 18. Arm rest base
- 19. Arm rest
- 20. Arm axis
- 21. Arm base

Installation of the Cartridge into the Shell

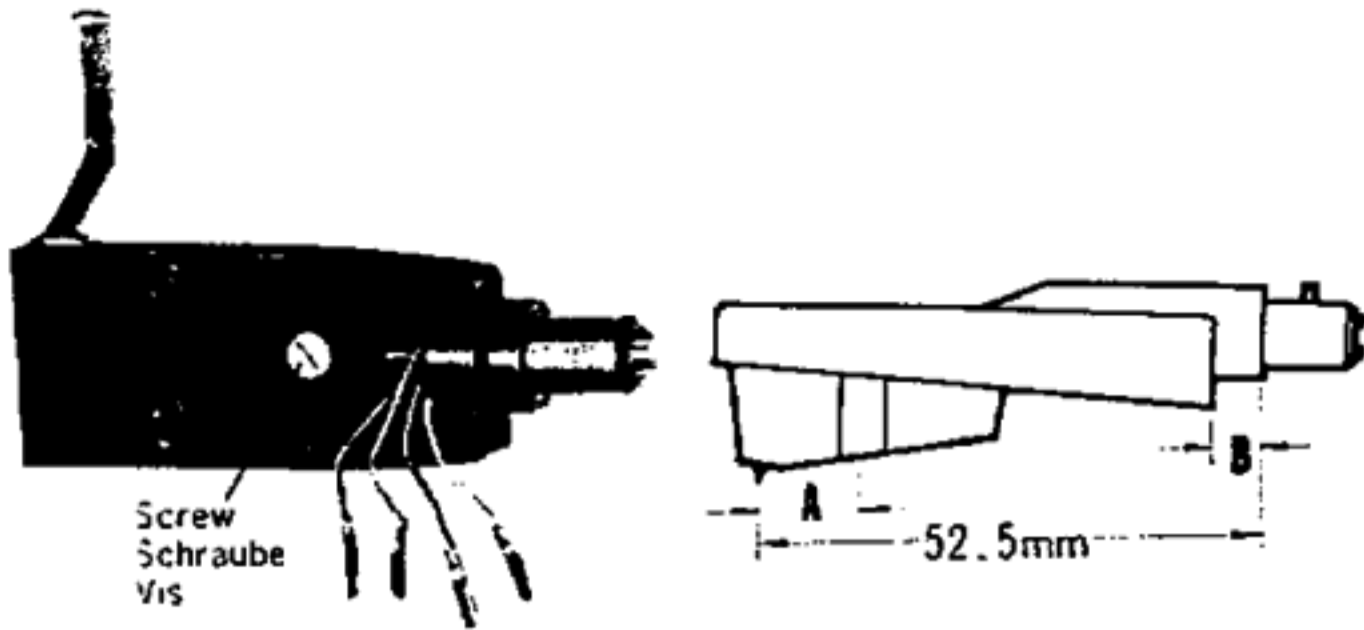

1. Loosen the screw located at the inside of the shell and slide the shell in order to get the correct stylus tip position. See illustration below. The correct stylus position is obtained by using the following equation:

A = the distance between the stylus tip and the mounting center of the cartridge.

B = the desired length

Equation: $B = 11/16'' (17.5 \text{ mm}) - A$

The SONY Stereo Cartridge VC-8E (moving coil type), has a distance between the stylus tip and the mounting center of $3/8'' (9.5 \text{ mm})$, "A."

Use the equation as follows:

$B = 11/16'' - 3/8'' (17.5 \text{ mm} - 9.5 \text{ mm})$, then

$B = 5/16'' (8 \text{ mm})$

Therefore, slide the shell so that **B** equals $5/16'' (8 \text{ mm})$. After adjusting to proper length tighten the screw. When the "A" specification is not given by the cartridge manufacturer, the distance from the stylus tip to the end of the shell should be $2-1/16'' (52.5 \text{ mm})$.

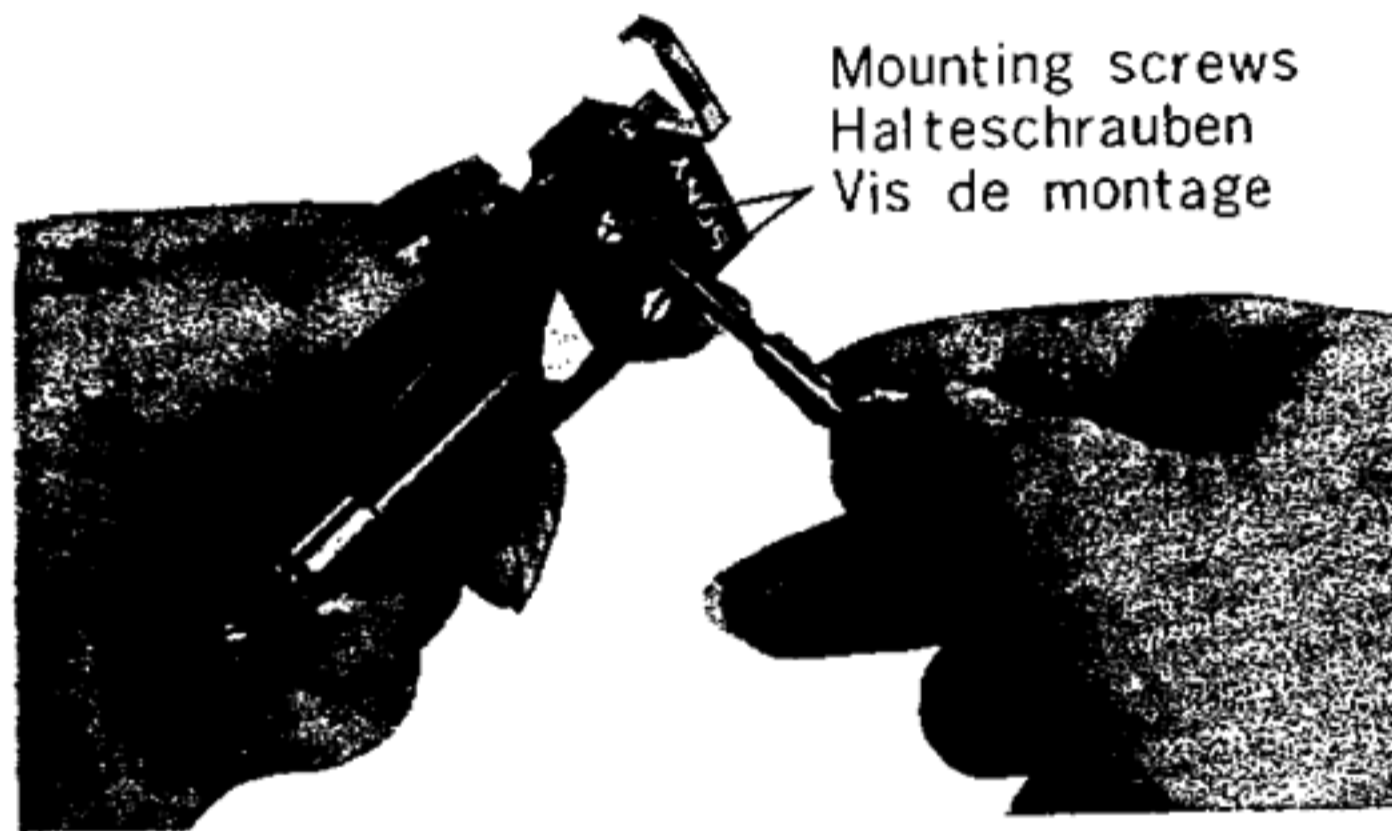

2. Secure the cartridge into the shell by tightening it with the mounting screws of the shell.

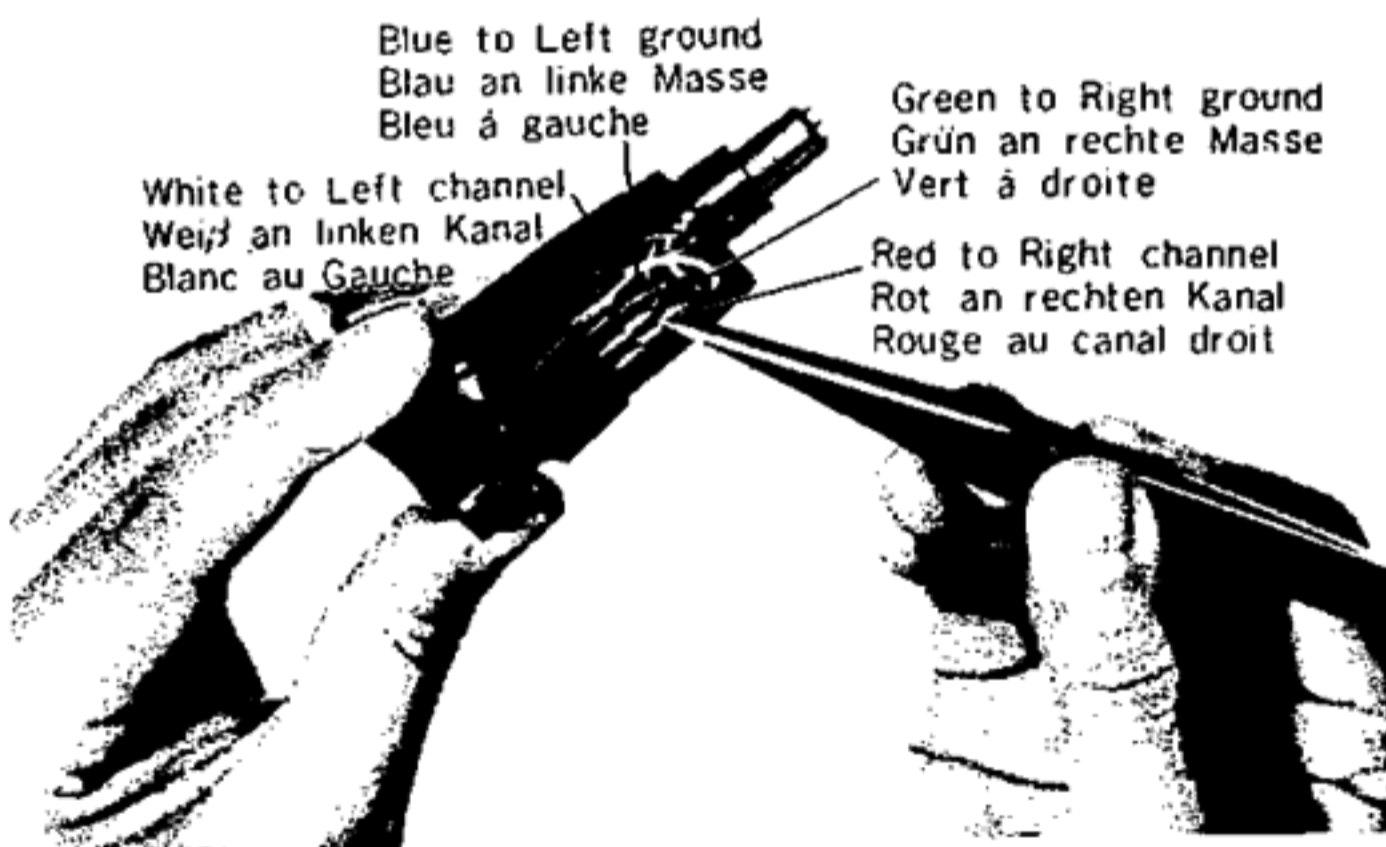

3. Connect the cartridge terminals to the four pin connectors of the shell as follows:

NOTE:

1. When installing very light cartridges (between 6 and 12 grams), insert the supplied ballast weight between the cartridge and the shell.
2. If the cartridge terminals do not match the connector tips provided on the lead wires, replace the connector tips with matched ones.

Mounting

Preliminary Mounting

1. Use the mounting pattern enclosed to mark the mounting holes of the arm and the arm-rest on the mounting board.

Be sure to allow clearance for counter weight assembly (1) in the rear of the mounting hole.

2. After loosening the set screws and removing the arm base (21) from the arm axis (20) and the armrest base (18) from the arm rest (19), install the arm base and arm-rest base into your mounting holes with the nuts and washers supplied.

A wrench is also supplied to help you with this installation.

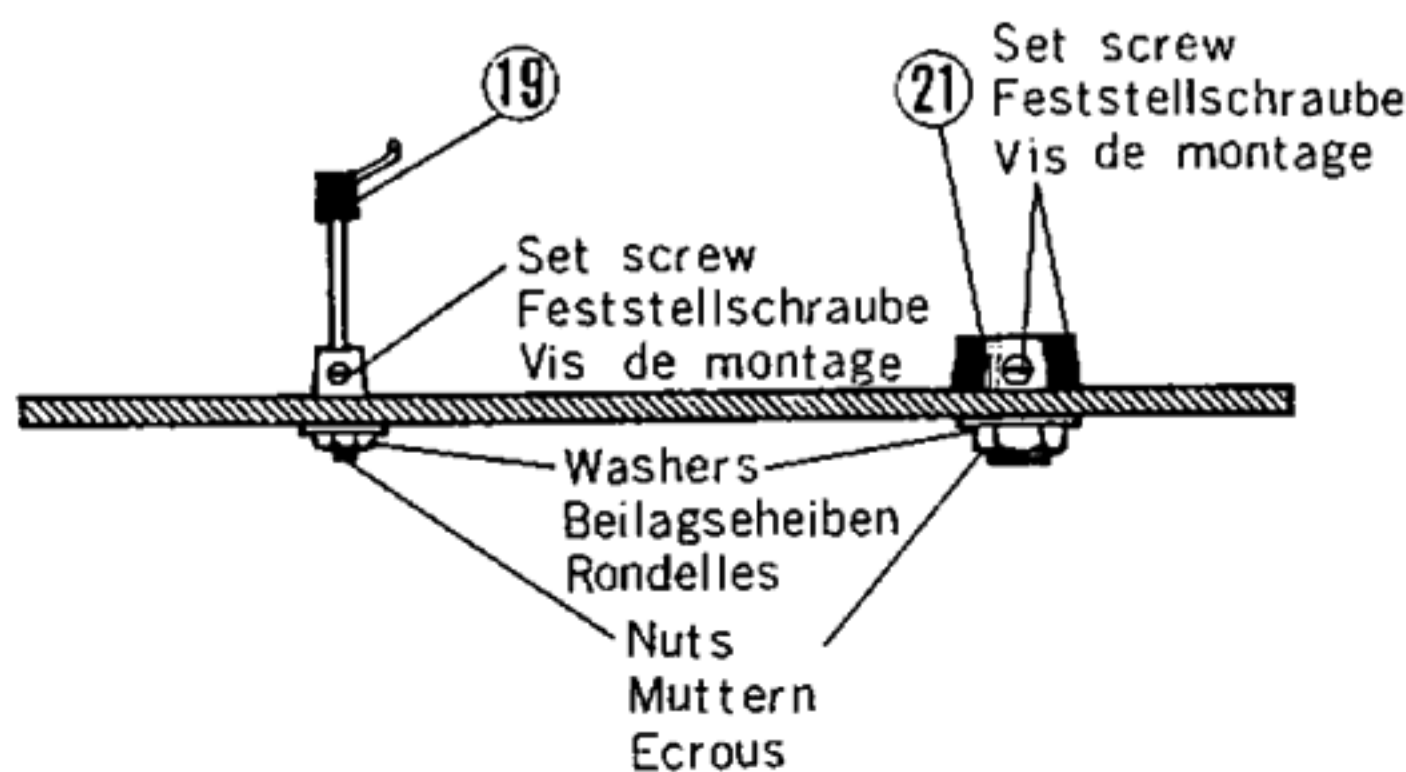

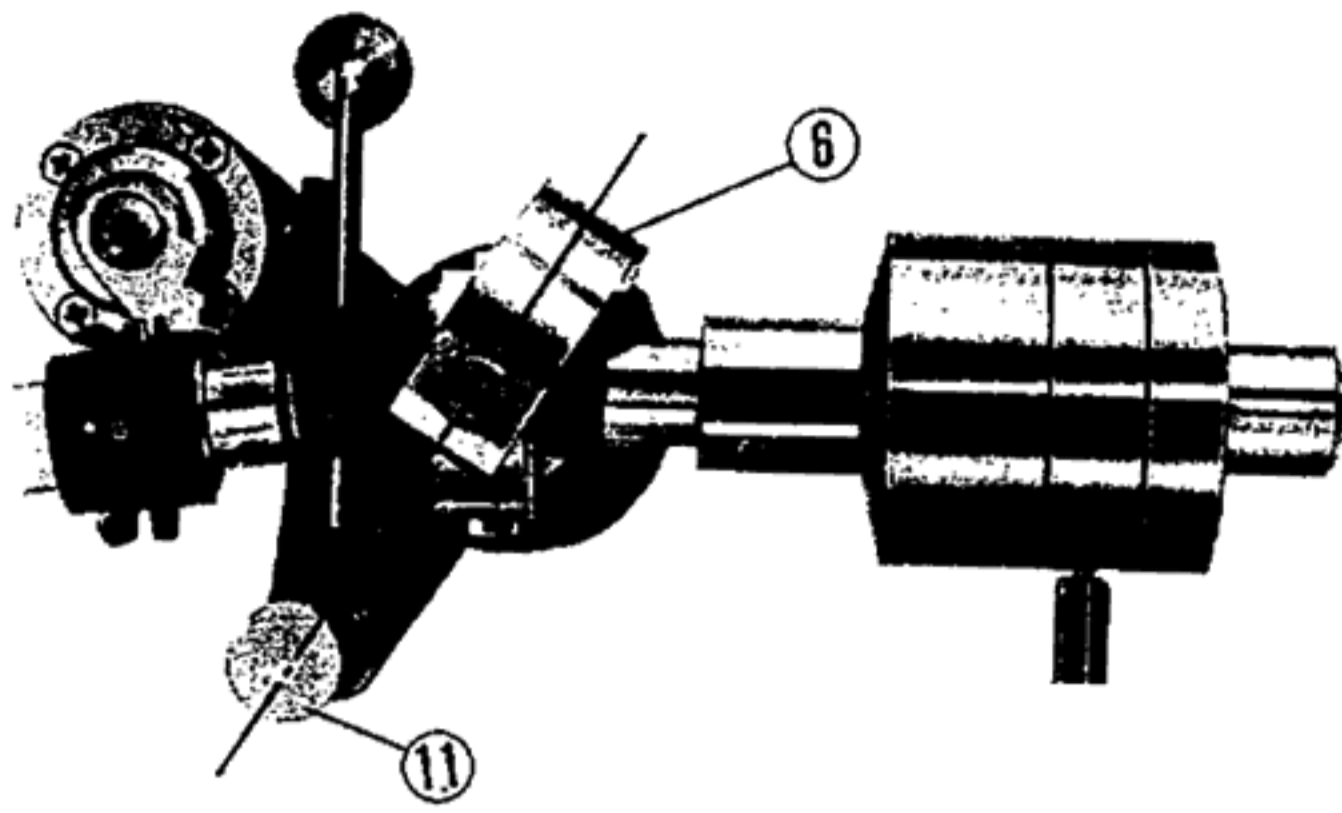

3. Set the arm-rest into its base at a temporary height by tightening the set-screw.

Now you are ready to mount the tone arm.

Actual Mounting

1. Before inserting the arm axis (20) into its base make sure that the gimbals support (6) is in a line with the bias compensator knob (11).

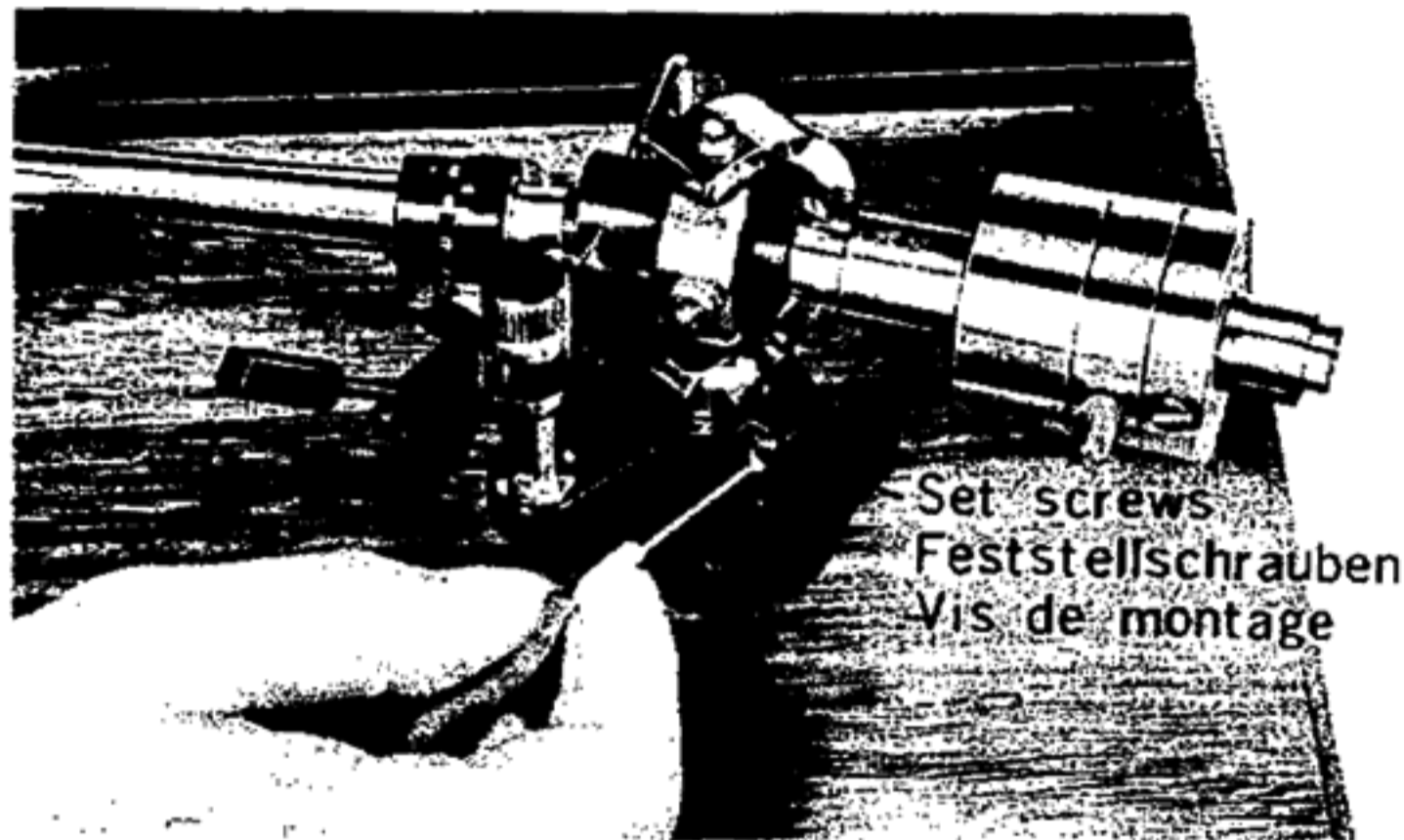

If they are not in a line, loosen the set screw of the cueing deck (10) in order to adjust it.

*It is not necessary to tighten the set screw of the cueing deck too firmly because the position of the cueing deck is re-adjusted again precisely on "Record Size Settings" on page 9.

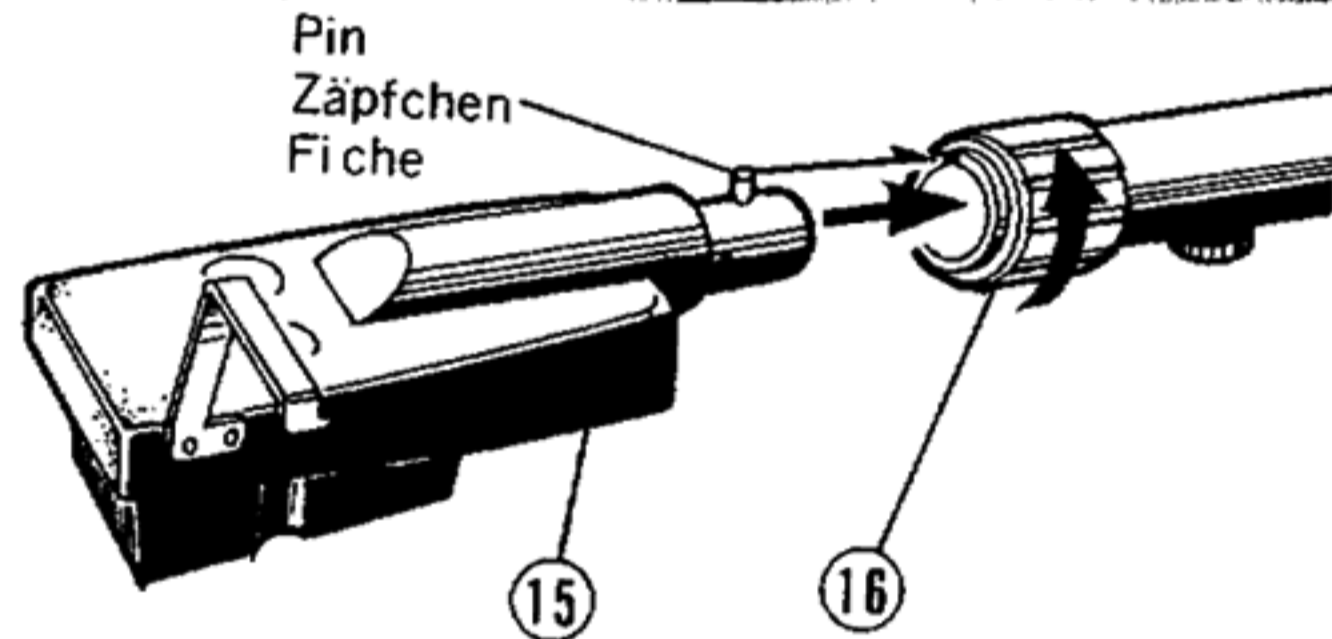

2. Insert the arm axis (20) into its base (21). Plug your pickup shell (15) to the tone arm. Be sure to lock the pin to the slot of the socket. Turn the locking collar (16) counterclockwise until the shell is firmly locked to the arm.

Now adjust the arm into position.

3. **First:** Approximately balance the arm horizontally as follows:

*Precise balance adjustments can be obtained on "BALANCE ADJUSTMENTS" on page 9.

Rotate the bias compensator knob (11) until the red point of the bias compensator reads the first indication of the knob.

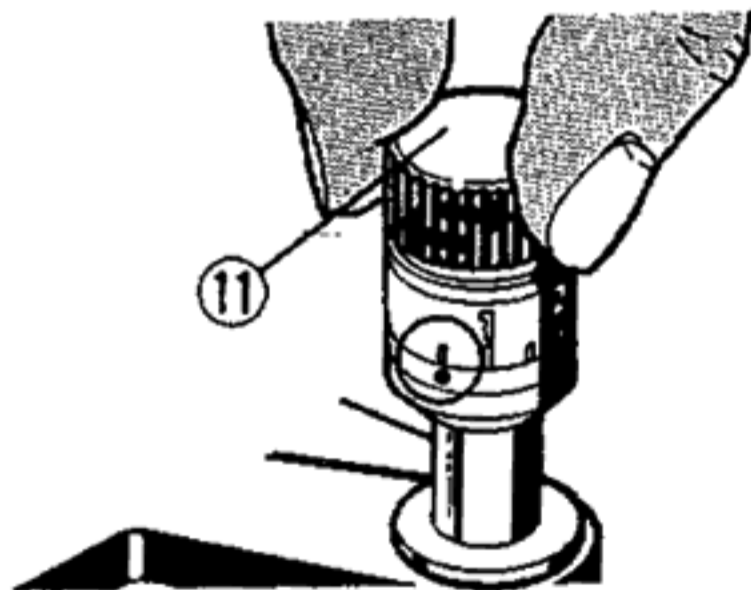

Lock the bias cam (3) to the lock pin of the cam as illustrated.

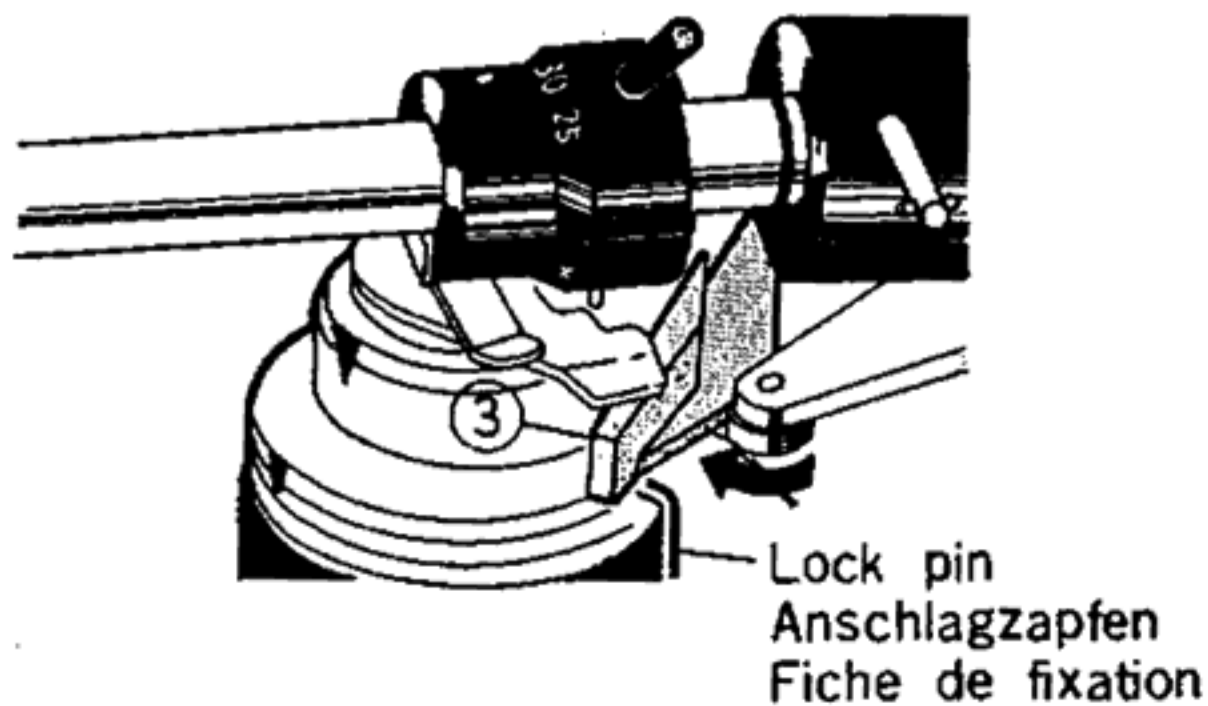

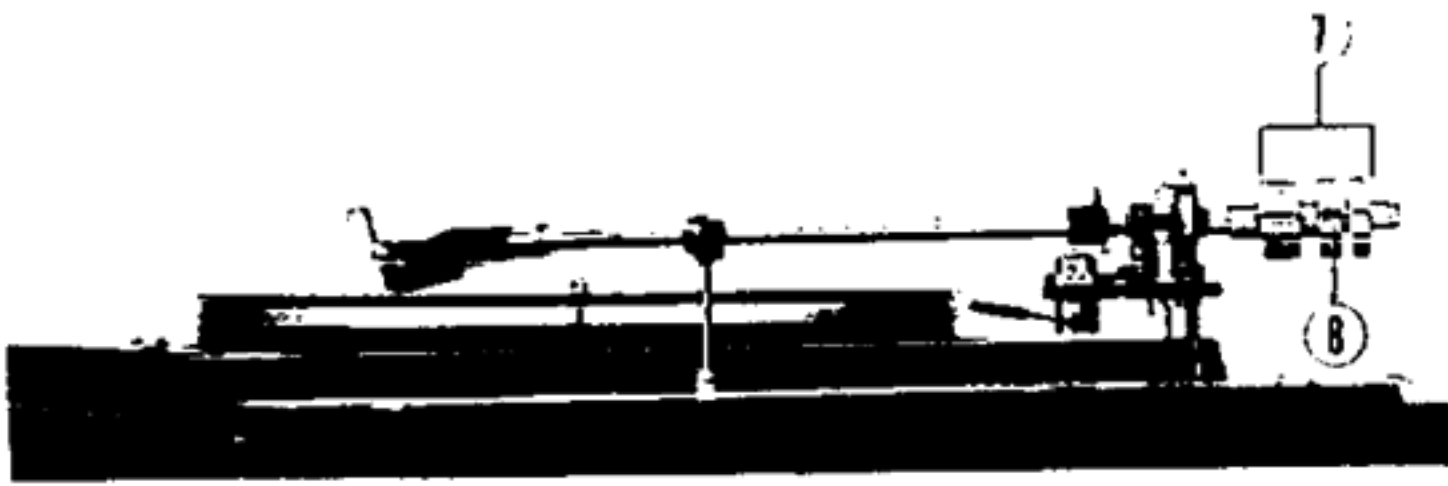

Loosen the knurled screw (8) and slide the counterweight assembly (7) and the vernier weight (7) - (C) to balance the arm.

When the arm is balanced approximately, tighten the knurled screw (8).

Second: After balancing, apply stylus force by sliding the stylus force weight (7) - (A) to the step [1.5] on the stylus force gauge (9).

Keep the set screws of the arm base loose for the following adjustments of **Third** and **Fourth**.

Third: the arm can swing left and right only so far on one side as the bias compensator knob (11) and on the other side as far as the gimbals support (6): Regulate the arm in the base so that the lateral balancer weight (4) touches the gimbals support only when the arm is over the spindle on your turntable.

Fourth: while holding the arm in your hand, gently lower the cartridge onto the record. Now adjust the arm height until the tone arm is in a HORIZONTAL PLANE with the turntable.

Tighten the set screws of the arm base gently.

4. Now move the tone arm to the arm-rest and adjust the arm-rest height to the same horizontal plane.
5. Make sure that when viewed from the front, the cartridge is level. If it is not, you can rotate the shell by loosening the cartridge angle adjustment screw (17).

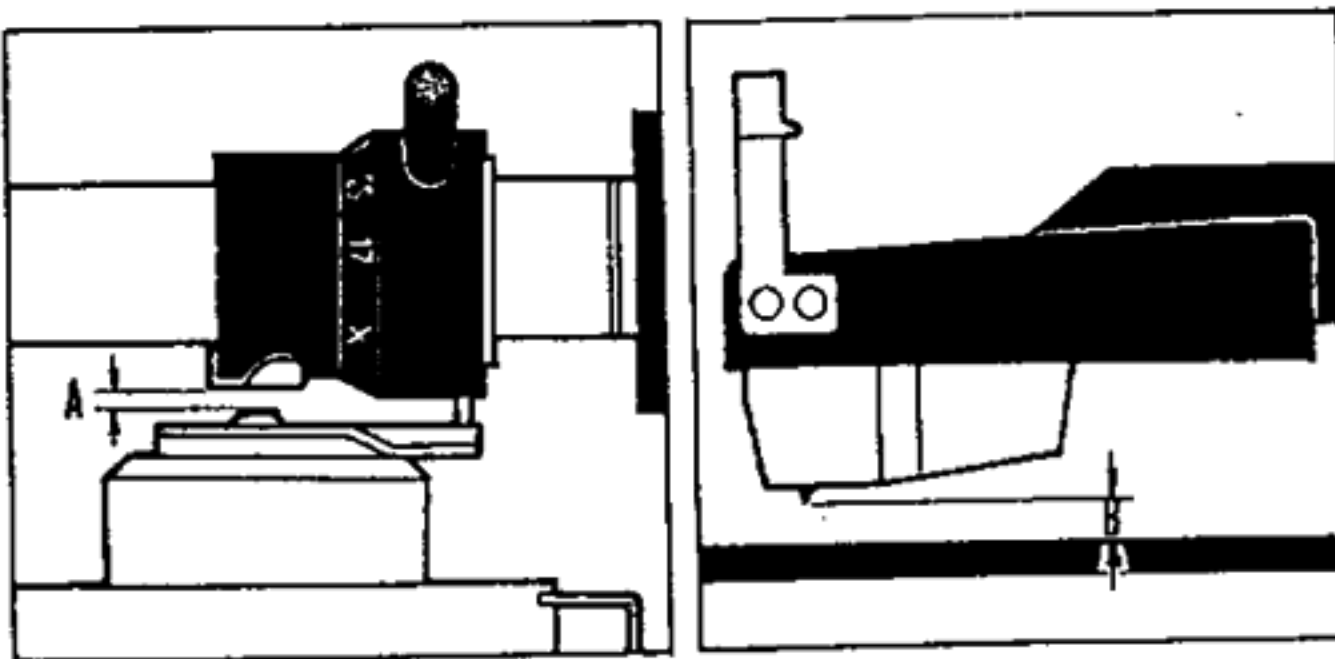
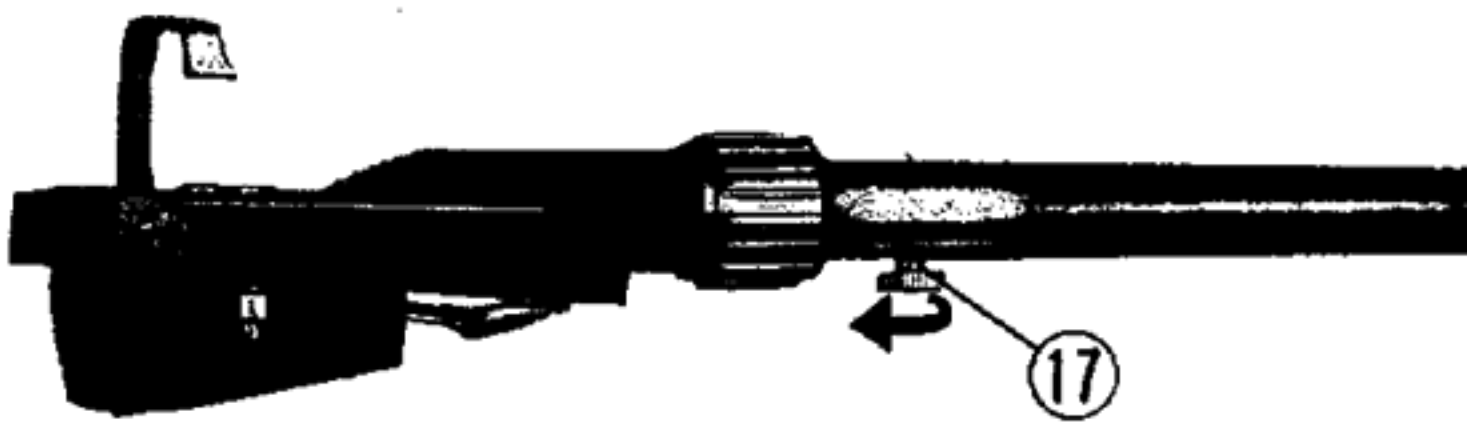
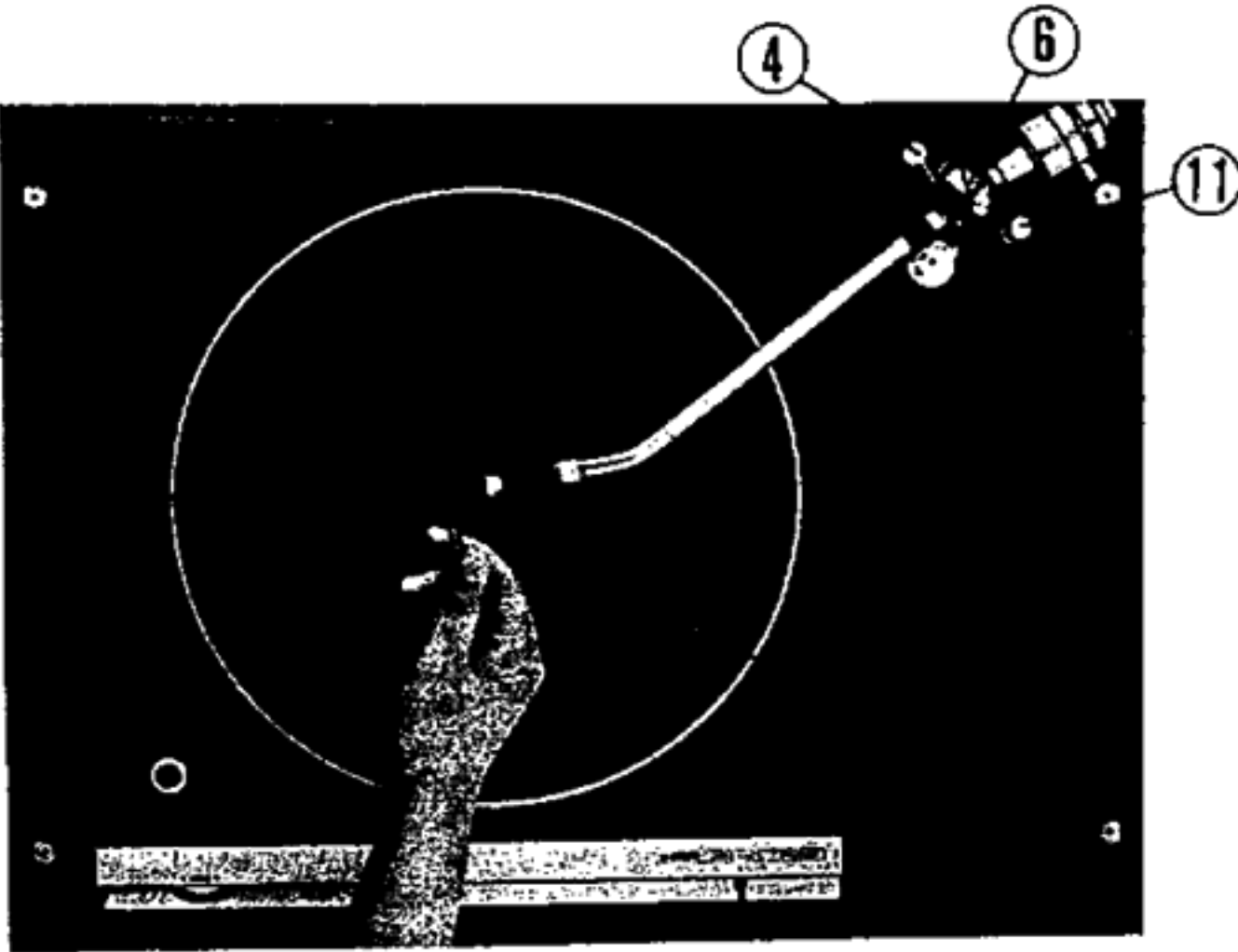

NOTE:

When the cueing lever (14) is in the down position and the stylus does not touch the record or when the cueing lever is in the up position and the stylus does touch the record, readjust the tone arm height.

The height of the arm axis should be such that when the cueing lever is lowered and the stylus touches the record, the space between the cueing track (13) and the cylinder rod is approximately 1/32" (0.8 mm), "A". When the cueing lever is lifted the stylus should be suspended more than 3/16" (5 mm) "B" over the record.

6. Connect the connecting cord to the axis beneath the base.

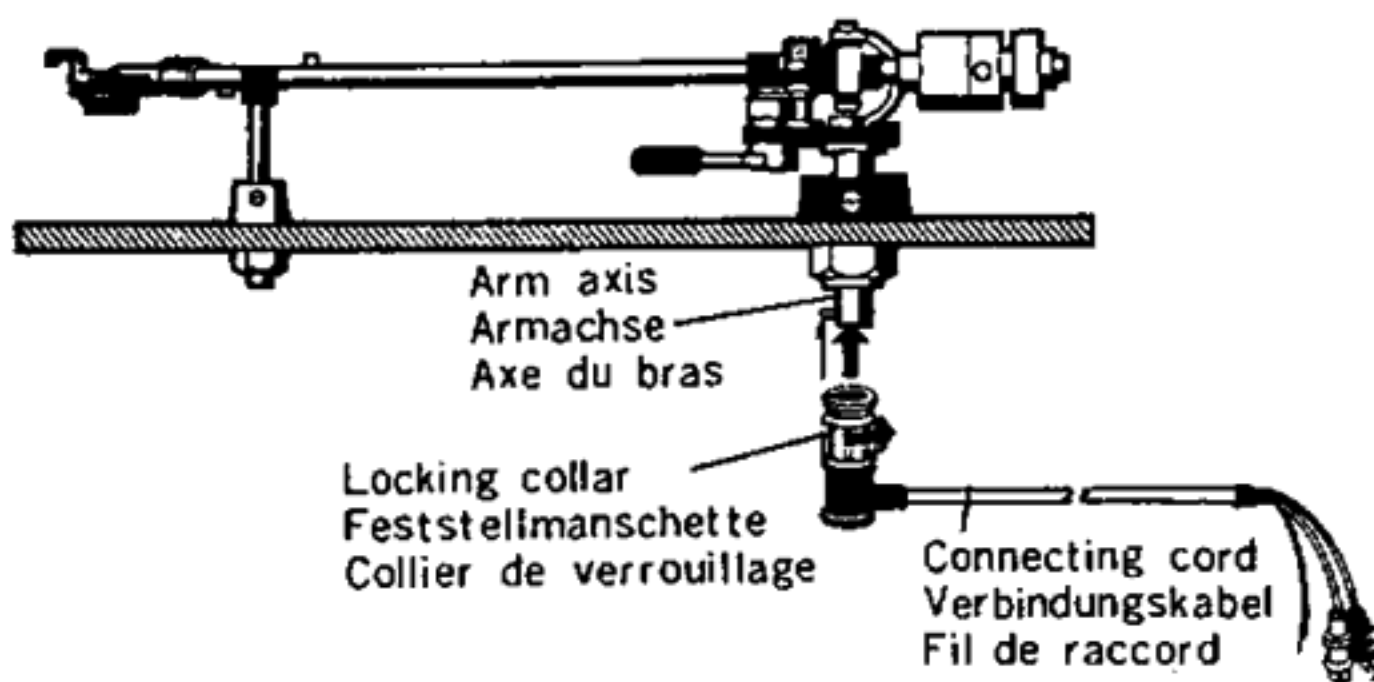

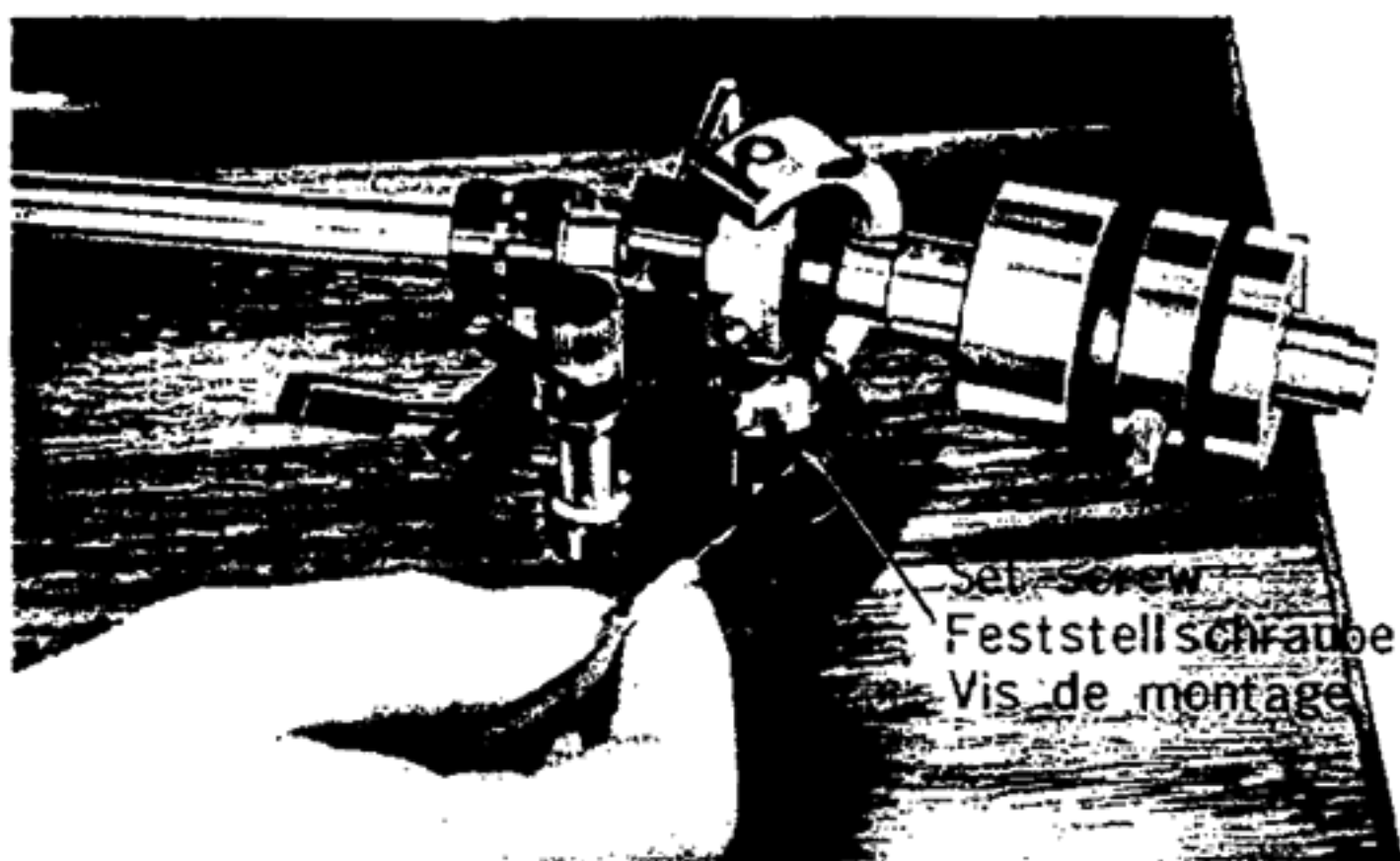

Record Size Settings

1. Cueing lever (14) should be in up position, and arm base set screws should be tightened. Now slightly loosen the set screw of the cueing deck (10).

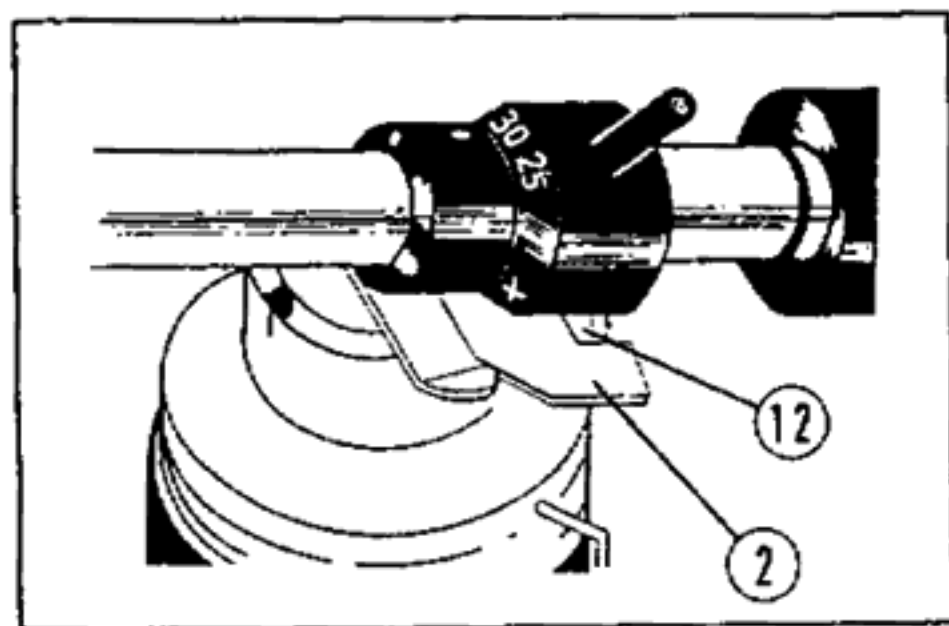

2. Turn the drop point selector (12) so that the red point is at [30] for the 12" (30 cm) record size.
3. Place a 12" (30 cm) record on your turntable.
4. Move the arm counterclockwise from the center position so that the pin of the drop point selector rests against the stop of the drop point preset cam (2).



5. Now slowly and gently move the cueing deck (10) and the tone arm simultaneously to the beginning of the 12" (30 cm) record.

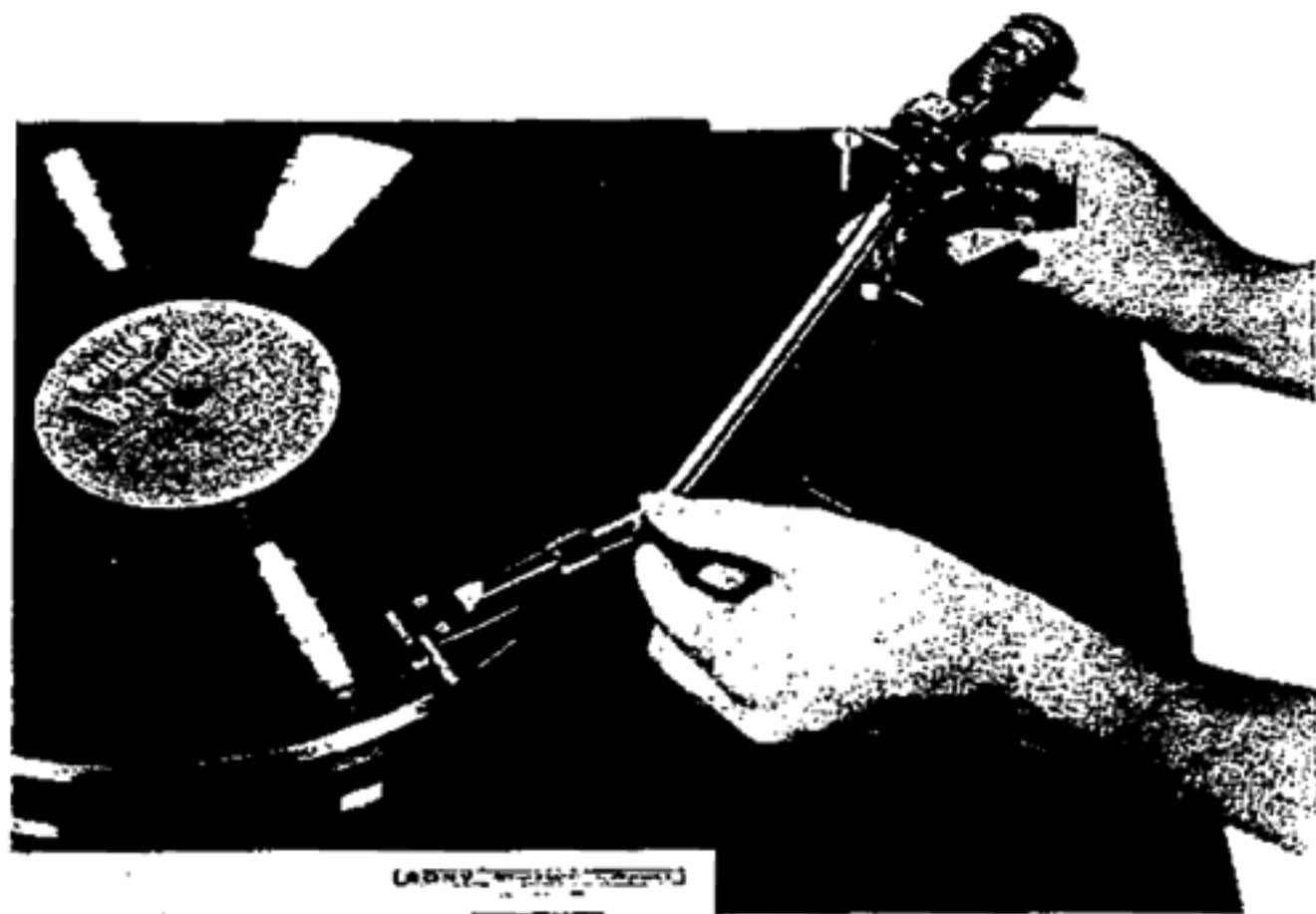

6. Now tighten the set screw of the cueing deck (10) gently while holding the cueing deck and tone arm in the position above the beginning of the 12" (30 cm) record.
7. Make sure that other record size can be set by setting the drop point selector (12) at the properly marked size, [25] is for 10" (25 cm) record, [17] is for 7" (17 cm) record.

Balance Adjustments

Set the drop point selector (12) to [X] position. This position sets the arm in free motion.

Lower the cueing lever (14).

Check that the bias cam (3) is locked to the lock pin of the cam. See "Actual mounting" step 3 on page 5.

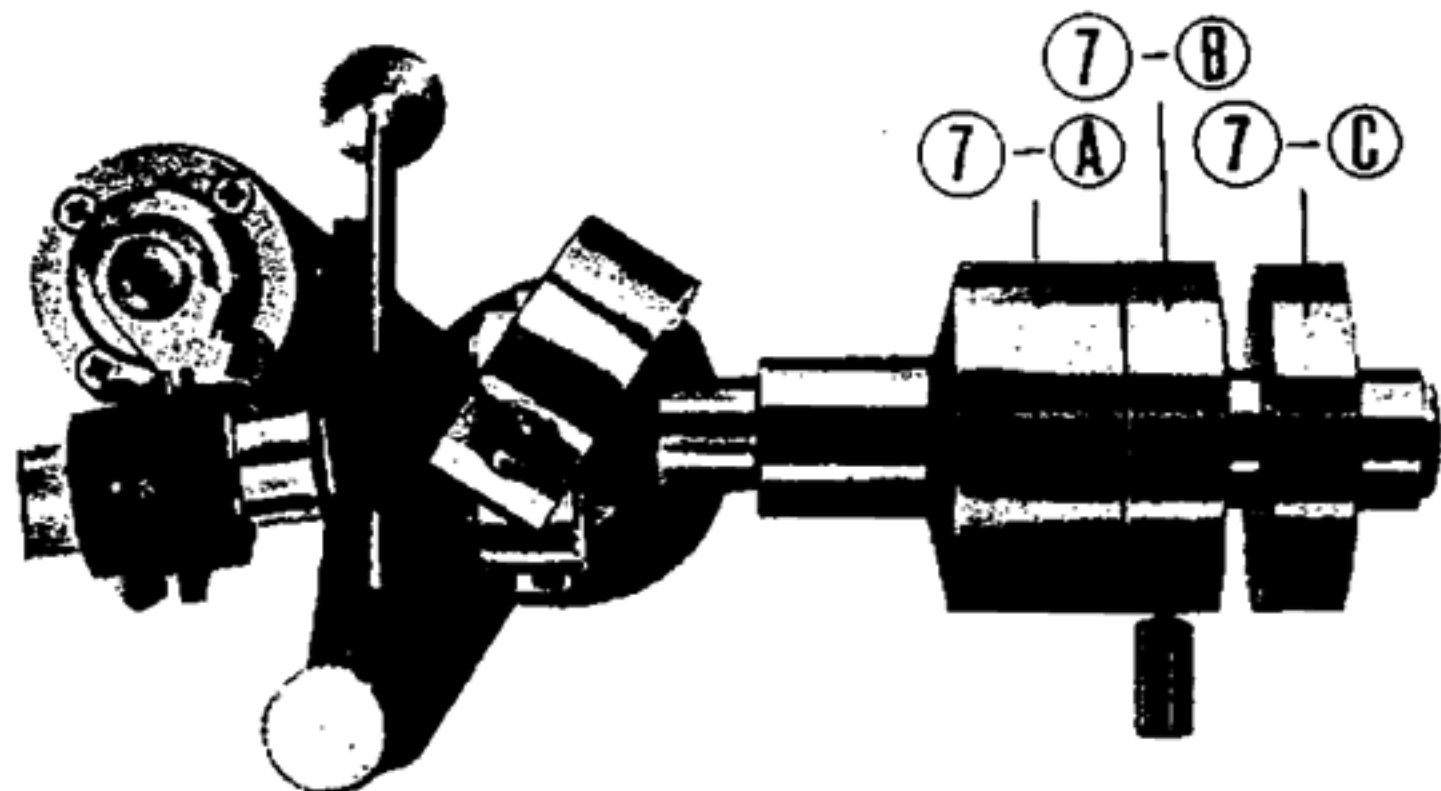

Longitudinal Balance

1. Slide the vernier weight (7-C) about 3/16" (5 mm) from the main weight (7-B). However, keep the stylus force weight (7-A) in contact with the main weight.

2. Release the arm from the arm-rest.
3. Loosen the knurled screw (8) of the main weight and slide the complete counterweight assembly (7) in order to obtain the approximate horizontal balance of the arm.
4. Now tighten the knurled screw (8).
5. For a precise horizontal balance manually slide the vernier weight (7) — (6) back or forth.

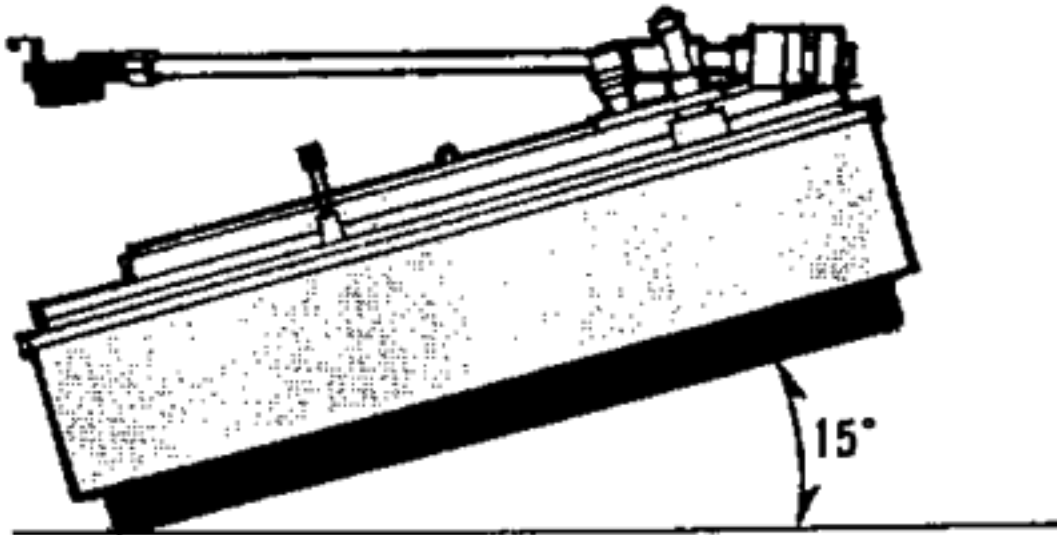

Lateral Balance

1. Release the arm from the arm-rest and balance it horizontally.
2. Make sure the bias cam (3) is locked to the lock pin.
3. Slowly tilt the mounting board approximately 15 degrees as illustrated.

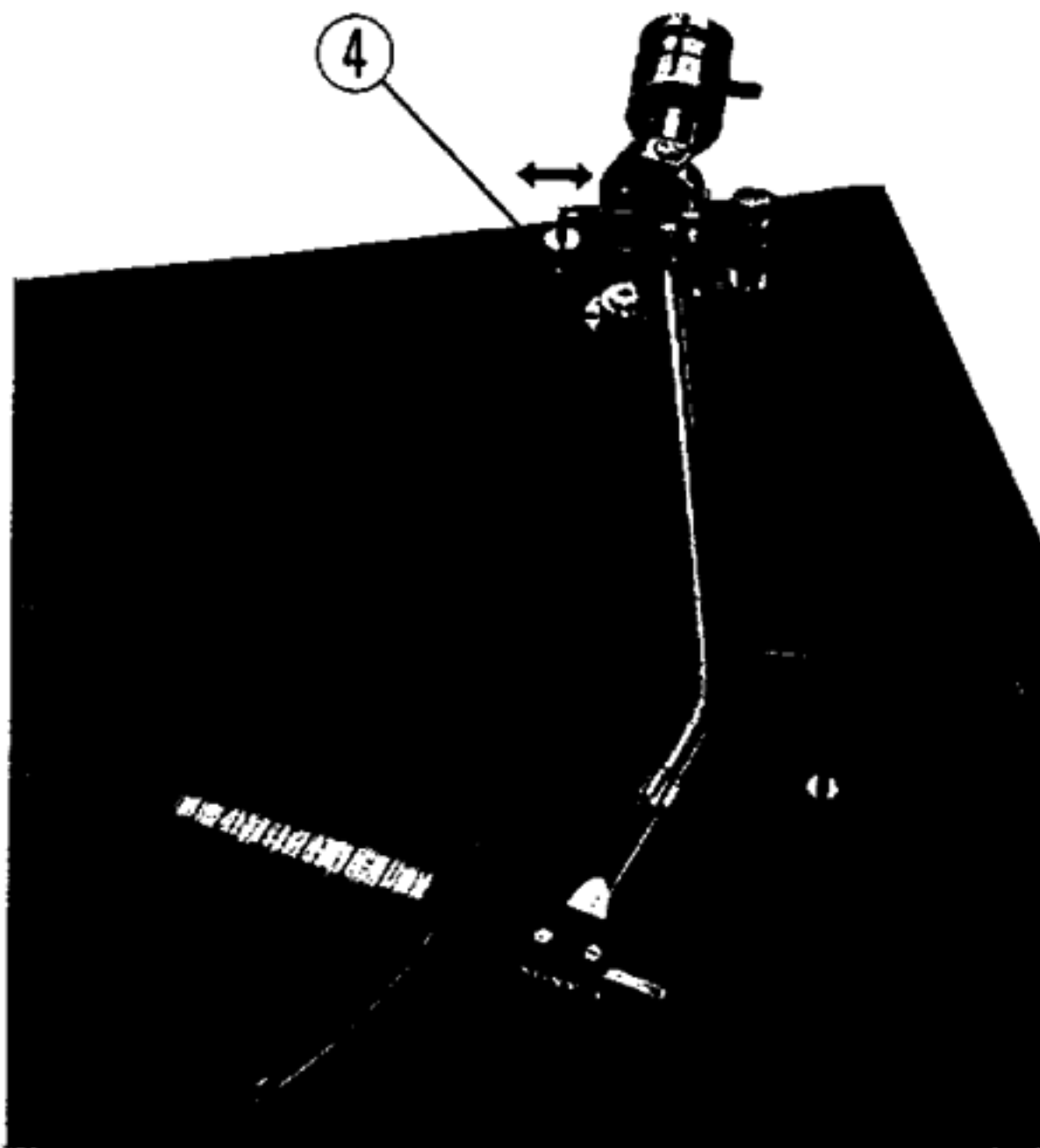

If the arm moves laterally, slide the lateral balancer weight (4) to the same direction in which the arm moves. Repeat this procedure until the arm stops.

Now the arm is balanced longitudinally and laterally at any position on your record.

NOTE:

When the lateral balancer weight is in the upper position of the balancer rod it is said to be in "neutral balance." This is the most desirable balance for this tone arm. However, due to excessive wrapping on a record or external vibration the stylus may skip over the disc groove.

You can correct this by moving the lateral balancer weight to a lower position on the balancer rod. This will keep the arm in a "stable balance" condition.

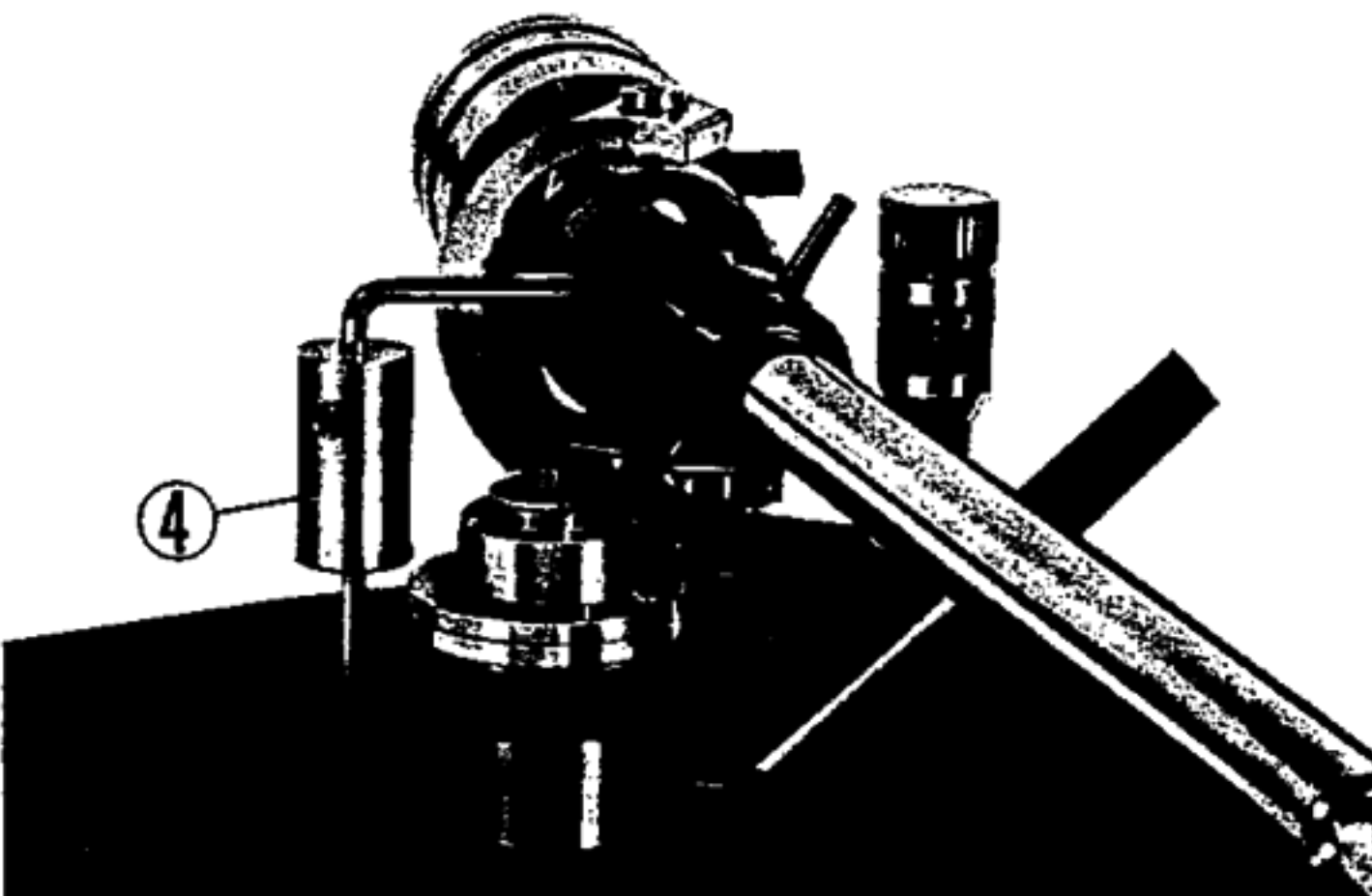

Stylus Force

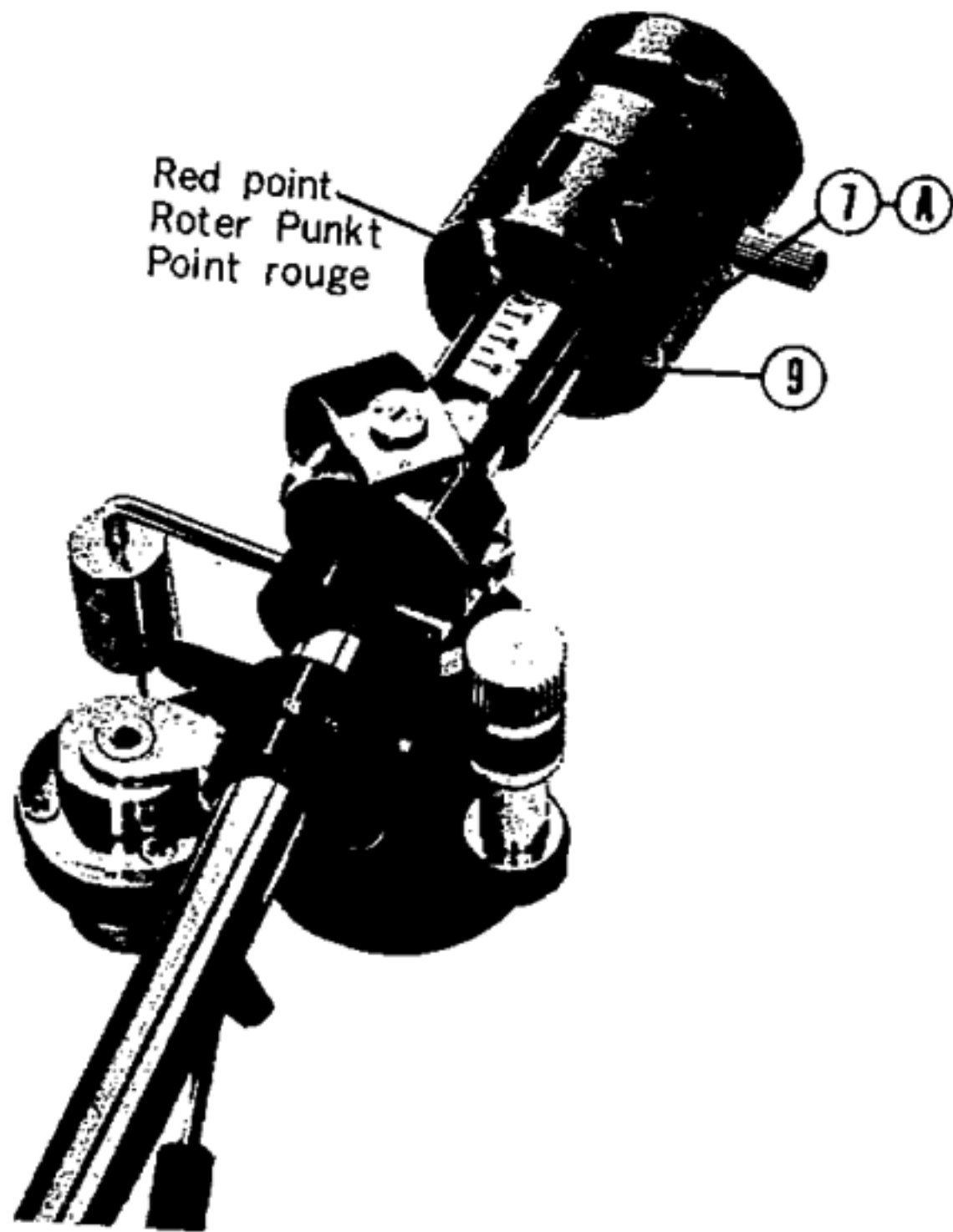

1. After balancing the tone arm laterally and longitudinally, slide and set the stylus force weight (7) - (A) to match the weight recommended for your cartridge. Each step of the stylus force gauge (9) represents 0.5 grams. The full gauge is 3 grams.
2. The stylus force weight is provided with a click-in device.
3. To use this click-in device, set the red point on the stylus force weight to the desired weight step; turn the stylus force weight left or right, move it to the desired weight step and then turn it so that the red point is over the step. It will click into place.
4. For other stylus force weights you may turn the stylus force weight to left or right and then slide it freely in order to select a special weight between the 0.5 gram steps provided.

Bias Compensator

The bias compensator is provided in order to cancel the natural inside skating force of a tone arm on a record.

1. Release the bias cam (3) from the lock pin.

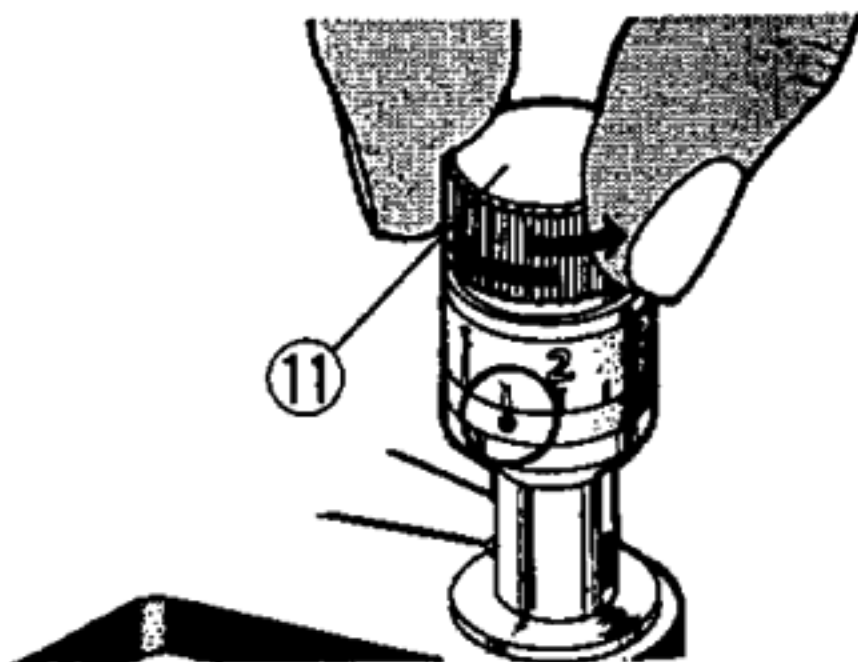
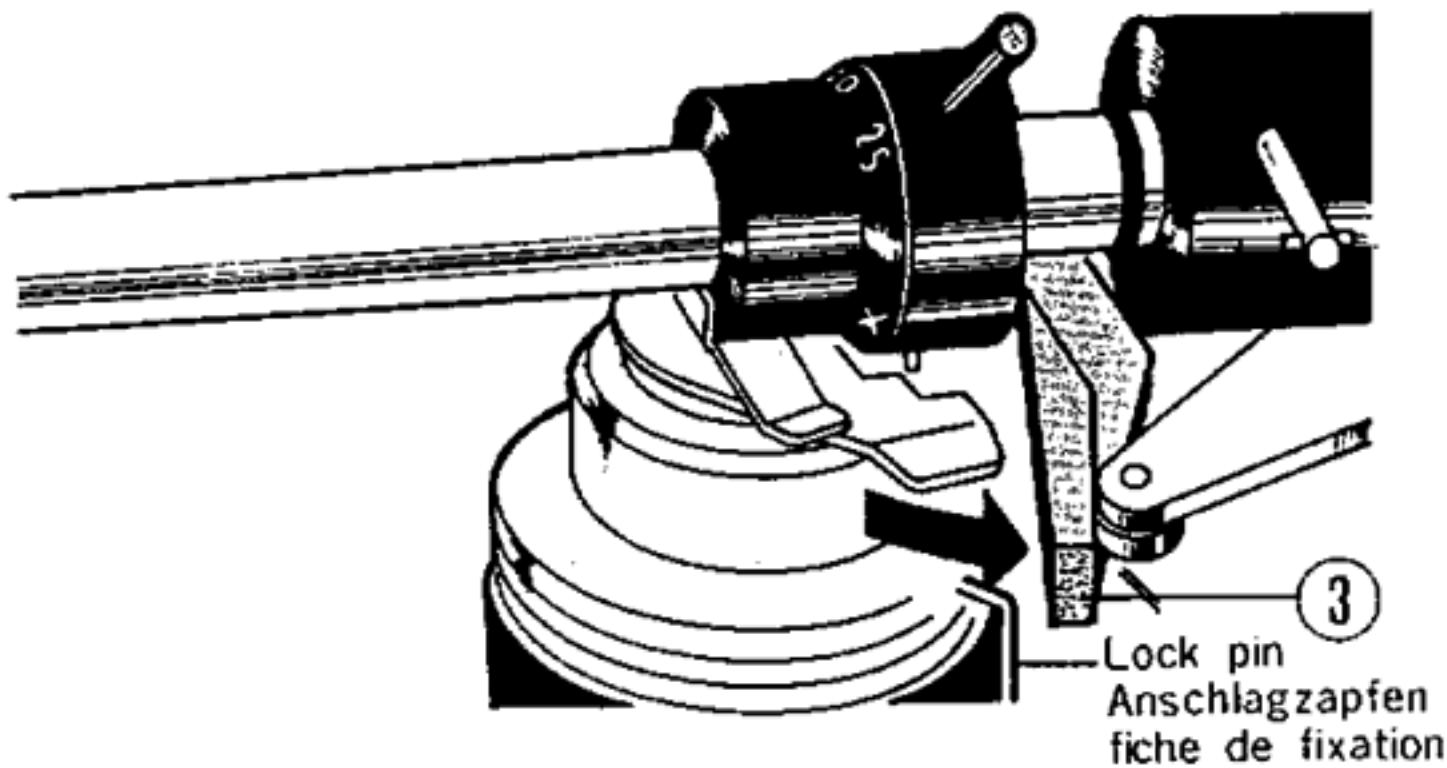

2. Rotate the bias compensator knob (11) until the red point matches the weight of the stylus force. Under ordinary conditions the bias compensator value should be the same as the stylus force weight.

Cueing Device

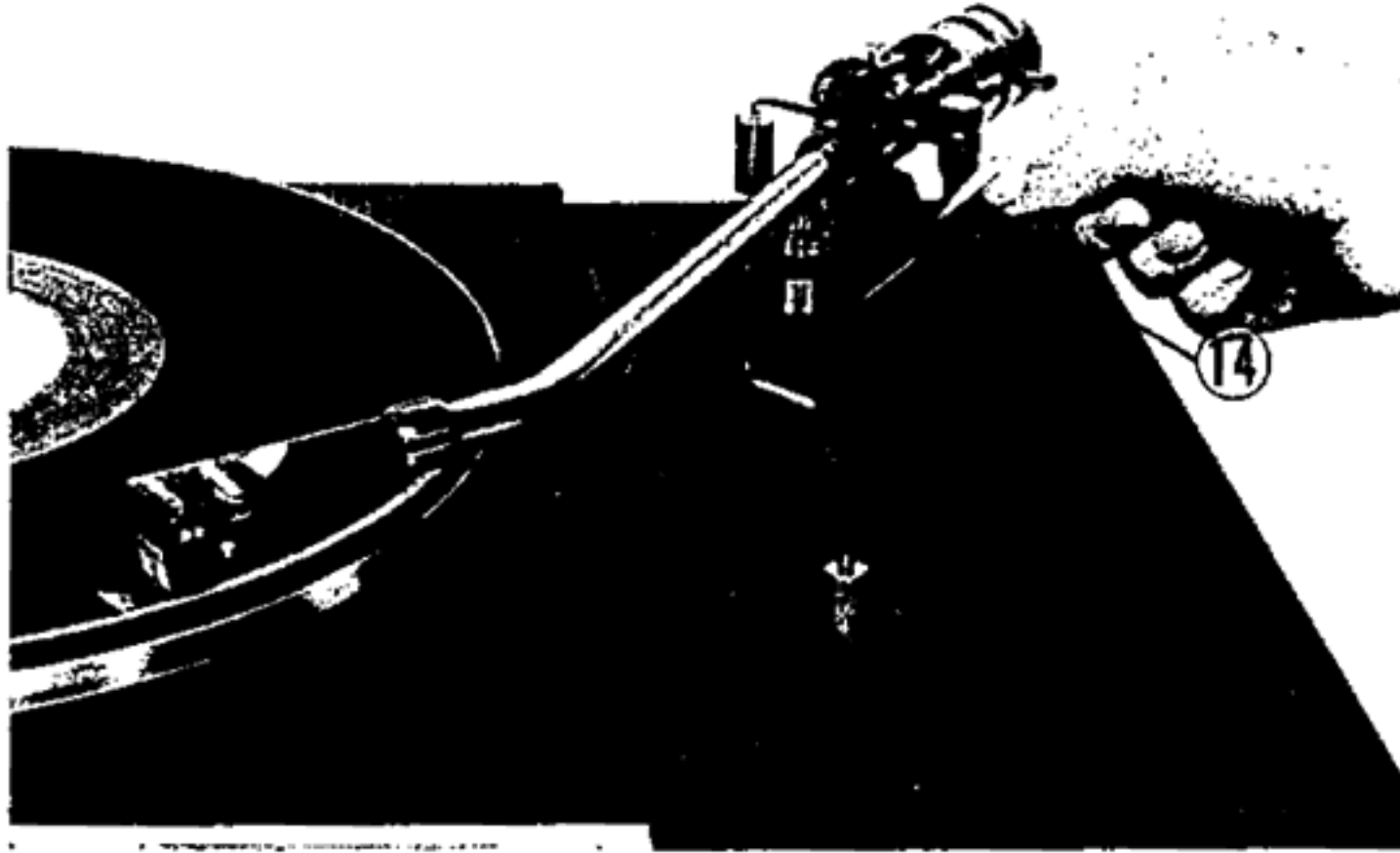

When the cueing lever (14) is in the "UP" position, the arm will be above the record. When the cueing lever is flipped downward, the cartridge will gently descend on the record.

The cueing device has a silicone oil damping mechanism which provides its integral cueing.

When selecting records to play, you should set the drop point selector (12) at the proper record size, (17) for 7" (17 cm), (25) for 10" (25 cm) and (30) for 12" (30 cm) records, move the arm to the beginning of the record, and flip the cueing lever downward. (X) position leaves the arm in free motion.

Connection to the Pre-amplifier

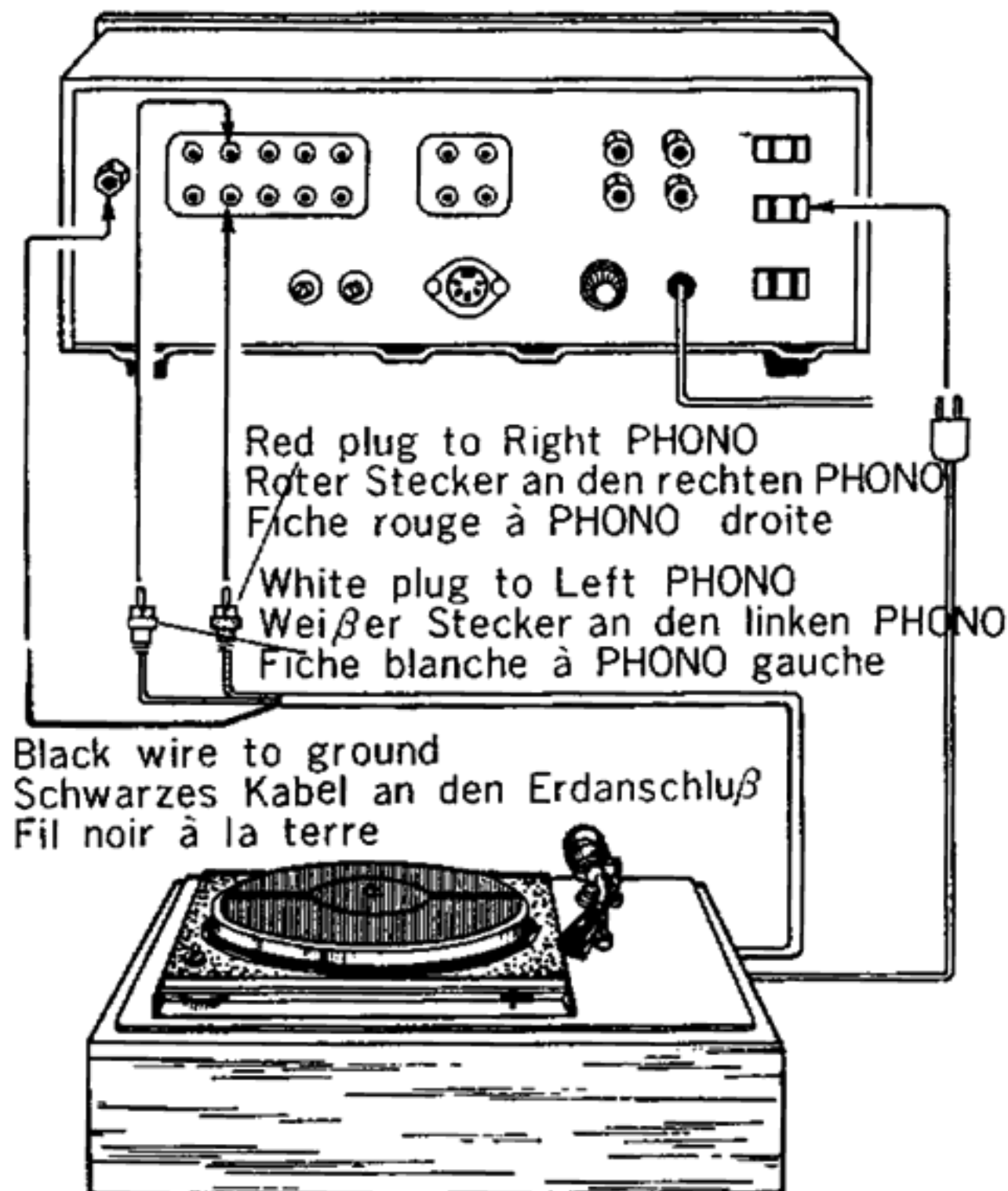

Insert the white plug of the connecting cord into the PHONO terminal of Left channel, the red plug into the PHONO terminal of Right channel, connect the black wire to the ground terminal of the pre-amplifier.

Note

- *Always handle the tone arm with the care required of all high precision instruments.
- *Do not use the arm in dusty places.
- *Screws and other controls NOT MENTIONED in this manual are for servicing adjustments, DO NOT TOUCH THEM.

Specifications

PUA-237

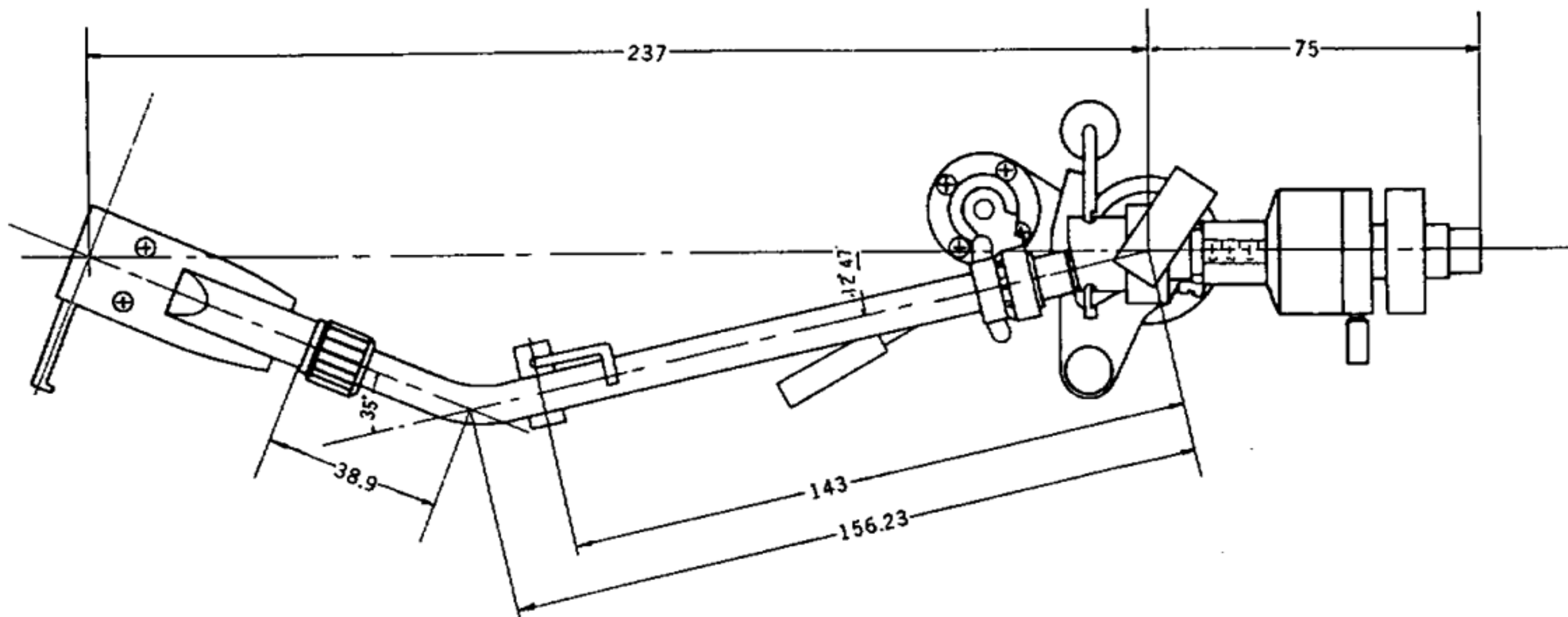

Overall Arm Length:	13-3/8" (340 mm)
Pivot to Stylus Length:	9-11/32" (237 mm)
Cartridge Offset Angle:	22° 13'
Tracking Error:	1° 44'
Arm Resonance: (Vertical)	9 Hz
(with VC-8E) (Lateral)	11 Hz
Overhang:	9/16" (15 mm)
Stylus Force Adjustment Range:	0 to 3 grams (with click-stop 1/2 gram increments)
Anti-Skate Setting Range:	0 to 3 grams (in 1/2 gram increments)
Lead-In Groove Settings:	7, 10 and 12 inches (17, 25 and 30 cm)
Cartridge Weight Range:	6 to 18 grams

PUA-286

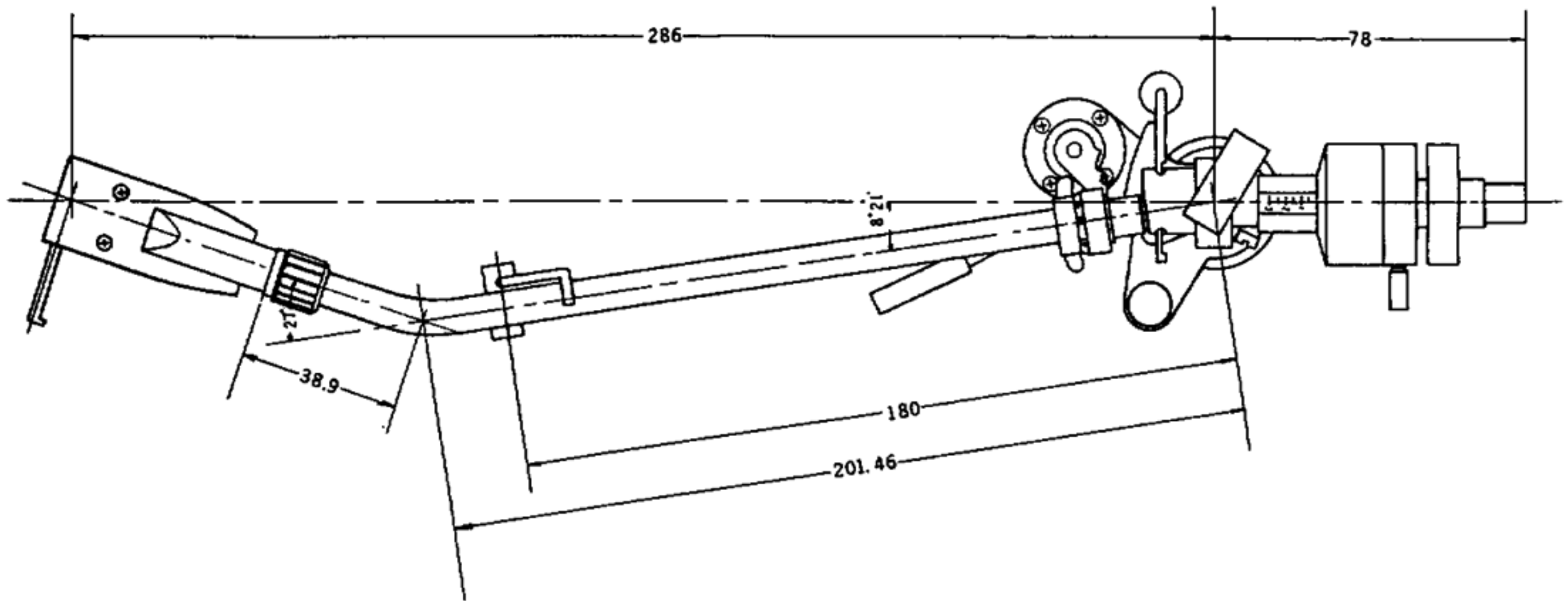

Overall Arm Length:	15-3/8" (390 mm)
Pivot-to Stylus Length:	11-1/4" (286 mm)
Cartridge Offset Angle:	18° 39'
Tracking Error:	1° 24'
Arm Resonance: (Vertical)	8 Hz
(with VC-8E) (Lateral)	10 Hz
Overhang:	1/2" (13 mm)
Stylus Force Adjustment Range:	0 to 3 grams (with click-stop 1/2 gram increment)
Anti-Skate Setting Range:	0 to 3 grams (in 1/2 gram increments)
Lead-In Groove Settings:	7, 10 and 12 inches (17, 25 and 30 cm)
Cartridge Weight Range:	6 to 18 grams

CHANGE ON THE CARTRIDGE ANGLE ADJUSTMENT SYSTEM

The cartridge angle adjustment screw (indicated No.17 in the manual) has been changed to a friction type system. The cartridge angle can be adjusted by rotating the shell end. Do not release the minus screw located at the under side of the arm pipe.

Please remember this when referring to page 2 (location of parts) and page 7 (Step 5).