

HiFi ENGINE®

For more Hi-Fi manuals and set-up information
please visit www.hifiengine.com

SERVICE MANUAL

STEREO AMPLIFIER **SA-9100** KUW, FVW

NOTE:

MODEL SA-9100 COMES IN TWO VERSIONS DISTINGUISHED AS FOLLOWS:

Round label on rear panel	Voltage	Type
KUW FVW	120V only 5-position selector	UL approved (U.S.A.) General export model

CONTENTS

1.	AMPLIFIER CHARACTERISTICS	2
2.	SPECIFICATIONS	3
3.	CONNECTION DIAGRAM	5
4.	FRONT PANEL FACILITIES	7
5.	BLOCK DIAGRAM	9
6.	CIRCUIT DESCRIPTION	
6.1	Equalizer Amplifier	11
6.2	Control Amplifier	11
6.3	Filter Amplifier	12
6.4	Power Amplifier	13
6.5	Protection Circuit	14
6.6	Power Supply Circuit	14
7.	DISASSEMBLY	15
8.	PARTS AND P.C. BOARD LOCATION	
8.1	Top View	16
8.2	Bottom View	17
9.	ALIGNMENT PROCEDURE	
9.1	Idle Current Adjustment	18
9.2	Adjustment of Neutral Potential	18
10.	EXPLODED VIEW AND PARTS LIST	19
11.	SCHEMATIC DIAGRAMS, P.C. BOARD PATTERNS AND PARTS LIST	
11.1	Circuit Connection Diagram and Miscellaneous Parts	23
11.2	Equalizer Amp Ass'y (AWF-007-0)	31
11.3	Control Amp Ass'y (AWG-018-A)	33
11.4	Filter Amp Ass'y (AWK-021-0)	37
11.5	Power Amp Ass'y (AWH-023-B)	39
11.6	Protection Circuit Ass'y (AWM-025-A)	43
11.7	Power Supply Circuit-A Ass'y (AWR-031-0)	46
11.8	Power Supply Circuit-B Ass'y (AWR-032-0)	48
11.9	Switch-A Ass'y (AV'S-038-0)	51
11.10	Switch-B Ass'y (AWS-039-0)	52
11.11	Switch-C Ass'y (AWS-040-0)	54
11.12	Volume Ass'y (AWX-048-0)	56
12.	PACKING METHOD AND PARTS NUMBERS	57
13.	SKELETON APPEARANCES OF TRANSISTORS	58

1. AMPLIFIER CHARACTERISTICS

POWER BANDWIDTH

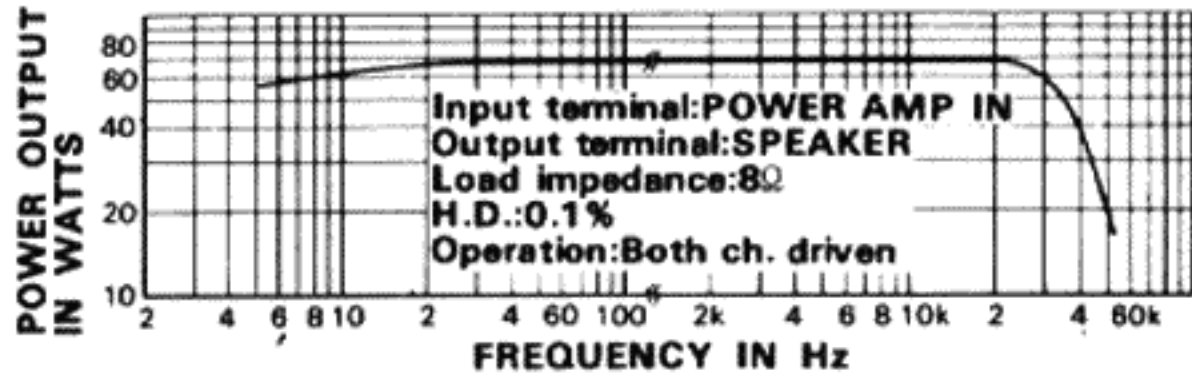

DAMPING FACTOR

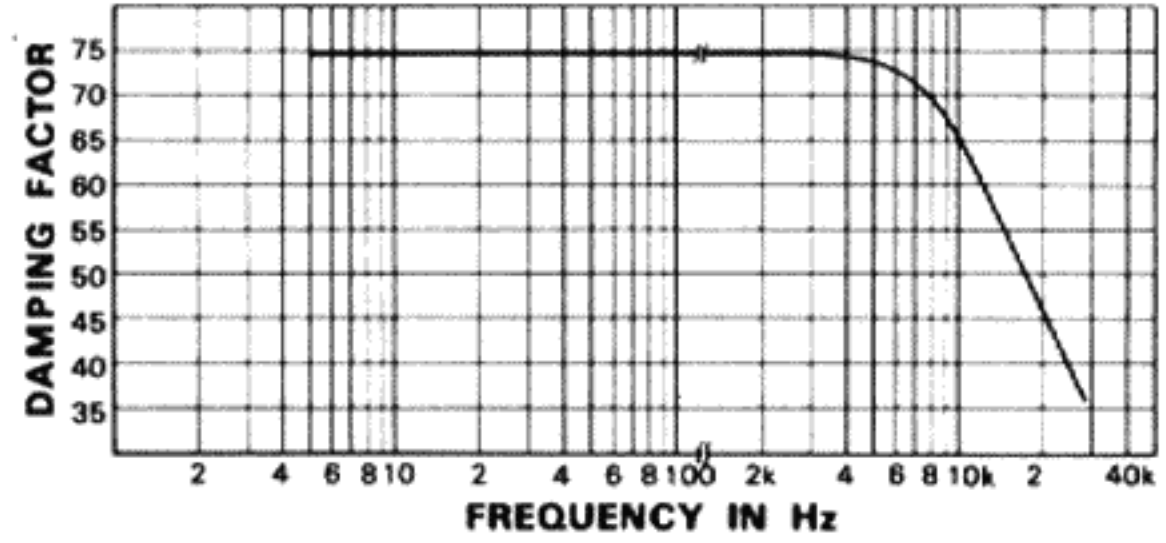

PHONO EQUALIZATION ACCURACY



MAX. PHONO INPUT LEVEL

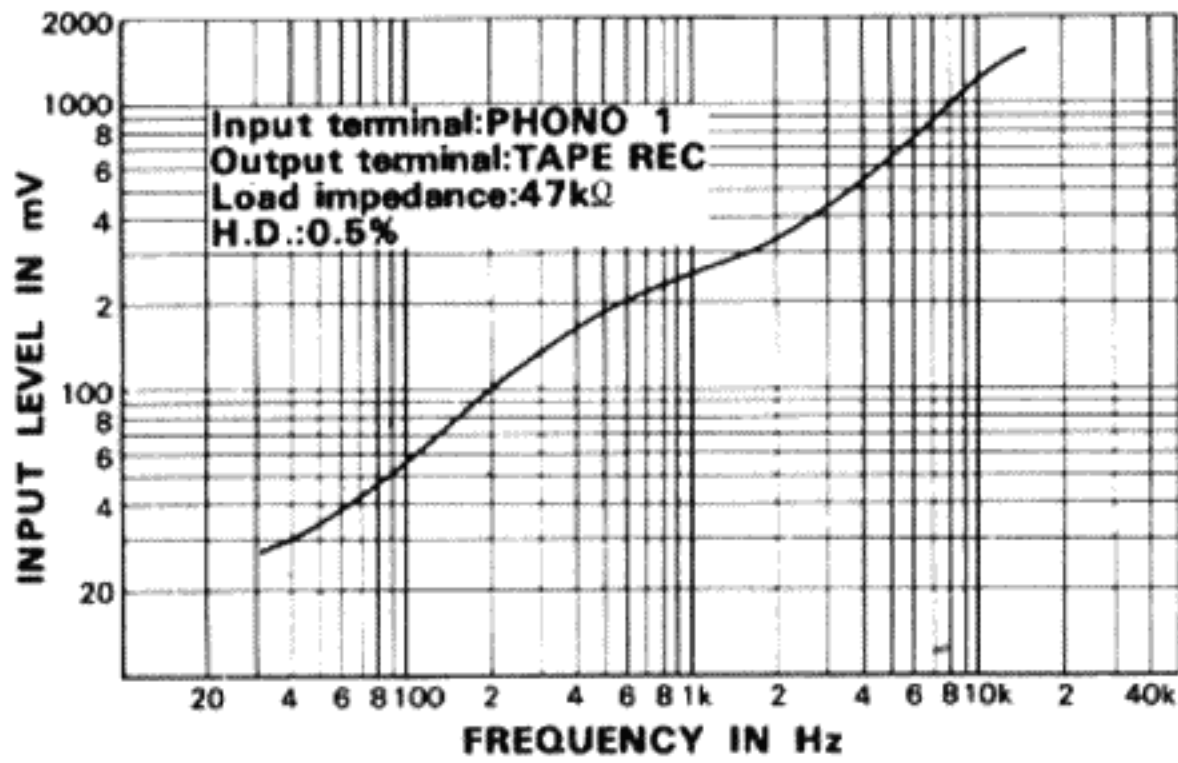

LOW AND HIGH FILTERS

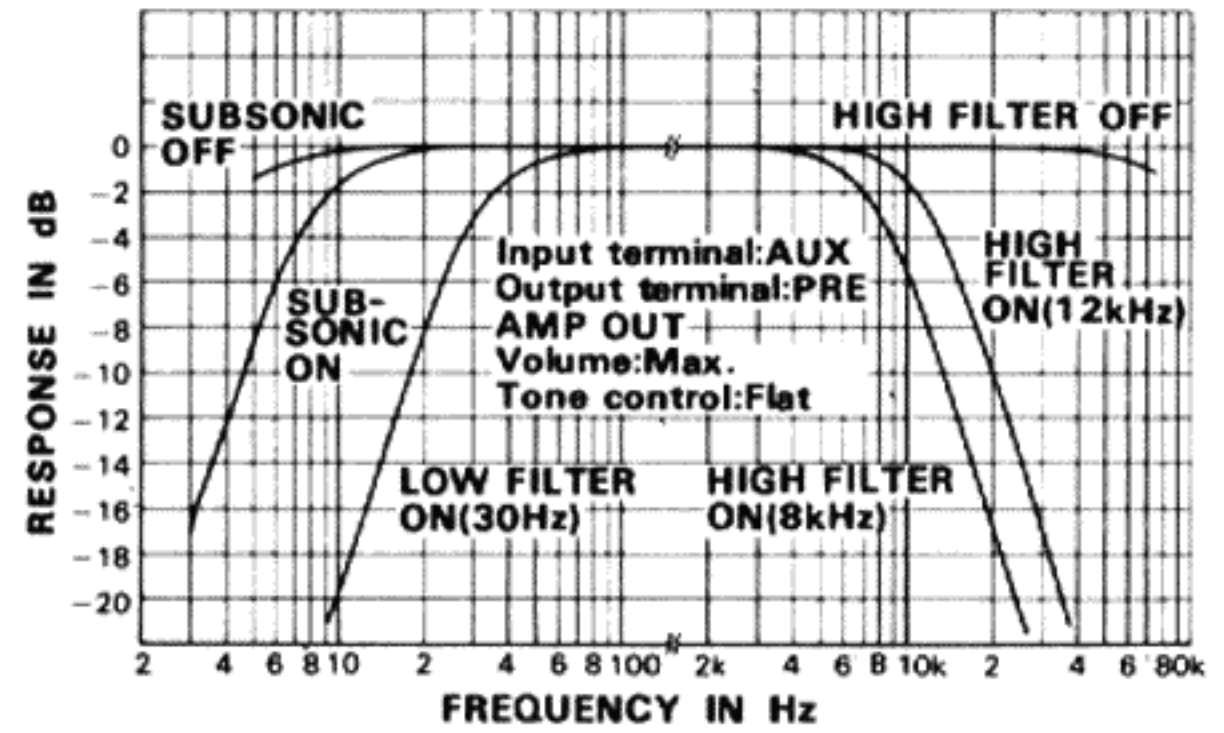

OUTPUT POWER vs. HARMONIC DISTORTION

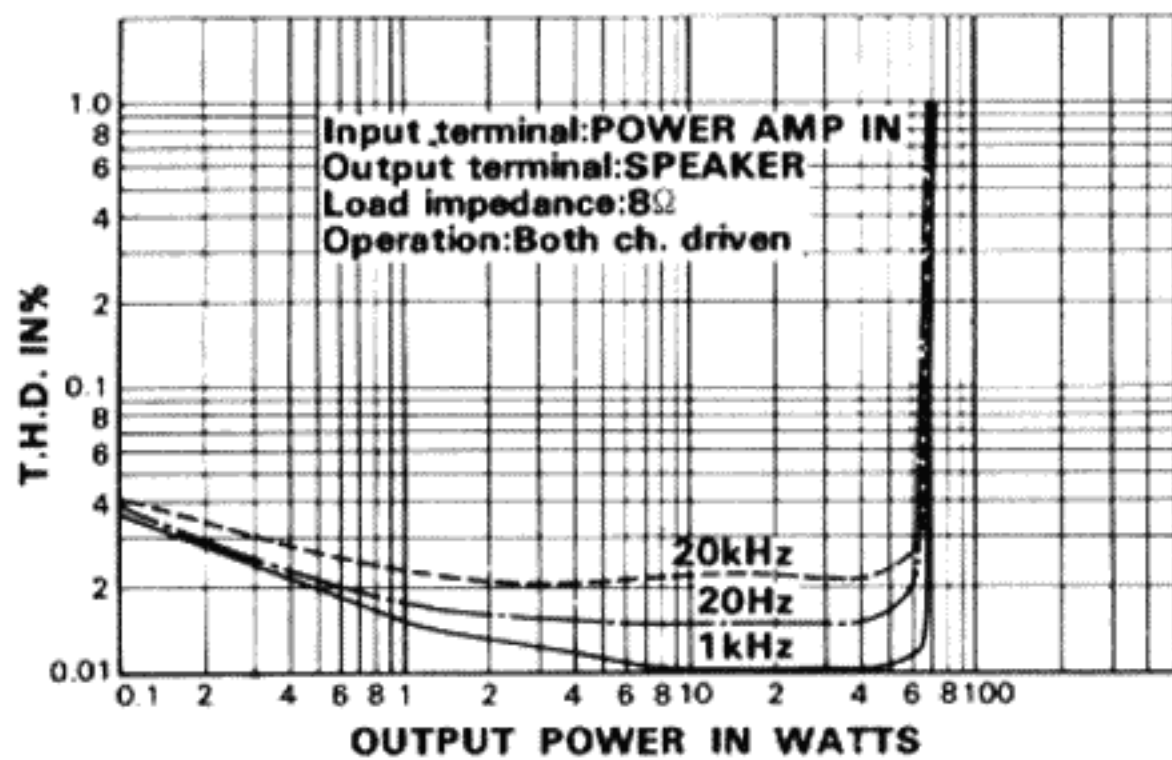

TWIN TONE CONTROLS (MAIN)

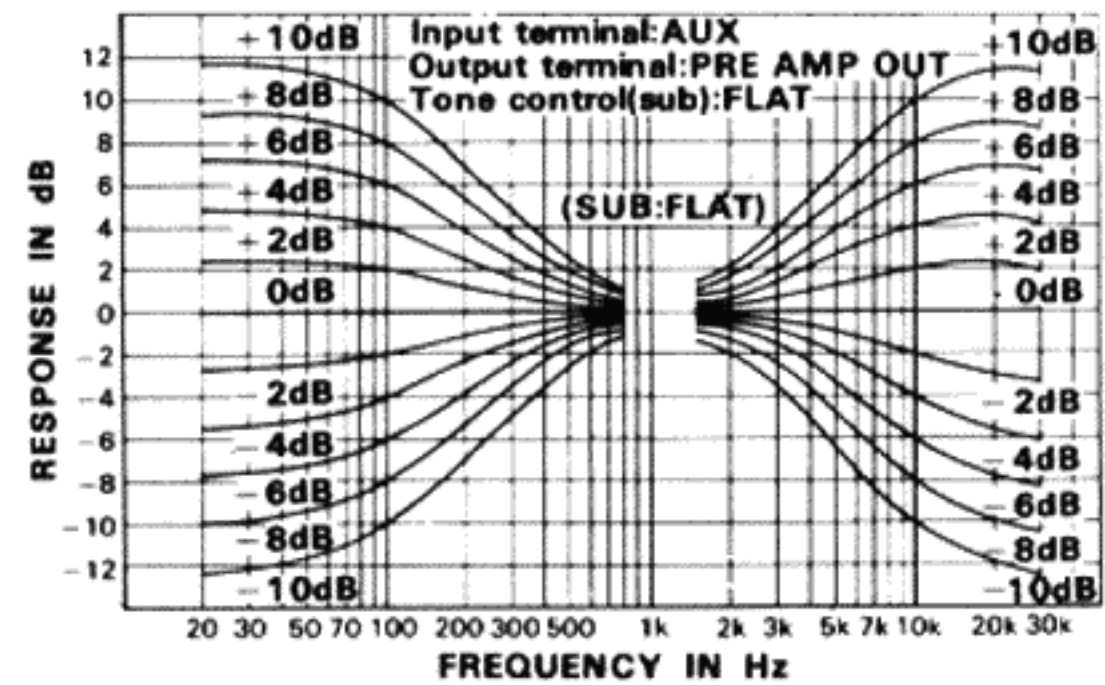

TWIN TONE CONTROLS (SUB)

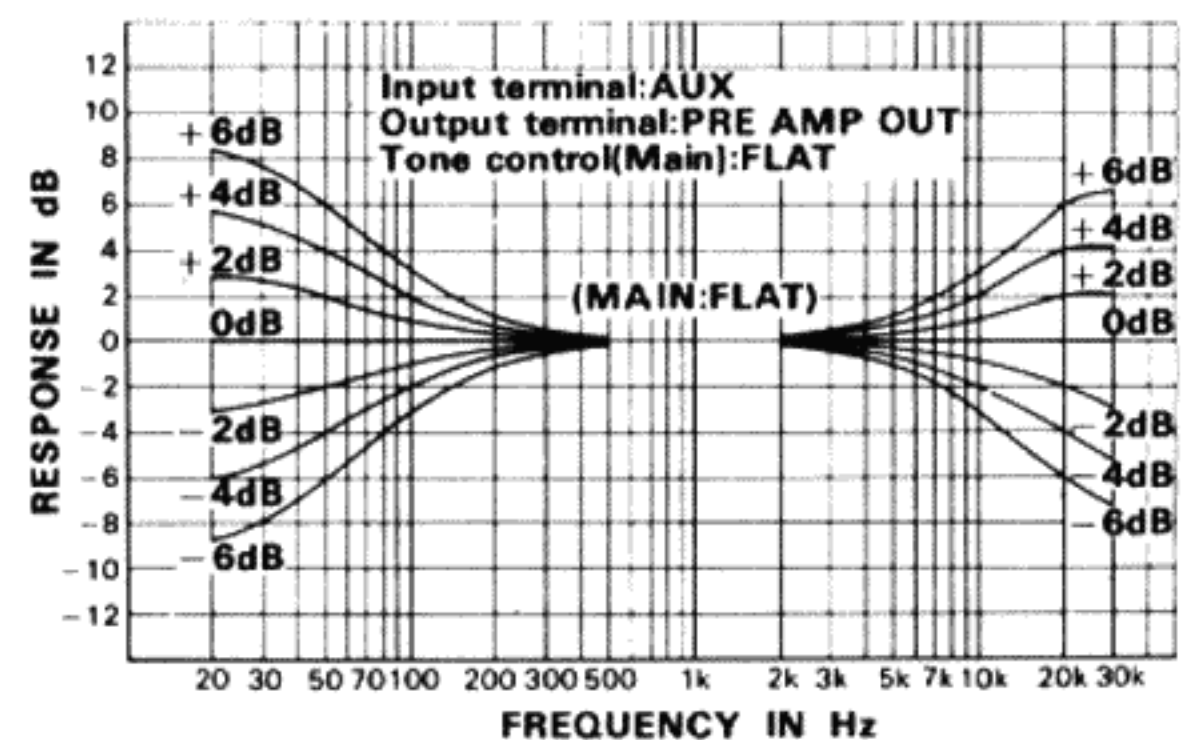

2. SPECIFICATIONS

SEMICONDUCTORS

Transistors 63
Diodes 30

POWER AMPLIFIER SECTION

Circuitry 2-stage Differential Amplifier, Direct Coupled Pure Complementary OCL

Continuous Power Output
20Hz~20kHz
(Both channels driven) 60W+60W(8Ω), 75W+75W(4Ω)
1kHz
(Both channels driven) 65W+65W(8Ω), 85W+85W(4Ω)
1kHz
(Each channel driven) 75W/75W(8Ω), 100W/100W(4Ω)

Harmonic Distortion
(Continuous Power Output) Less than 0.1%
(1W+1W Power Output) Less than 0.04%

Intermodulation Distortion
(Continuous Power Output) Less than 0.1%
(1W+1W Power Output) Less than 0.04%

Power Bandwidth (IHF, Both channels driven) 5Hz~40kHz (H.D. 0.1%)

Frequency Response 7Hz~80kHz ±1dB

Input Sensitivity/Impedance
POWER AMP IN 500mV/50kΩ

Output, Speaker A,B,C,A+B, A+C (4~16Ω)
Headphones 4~16Ω

Damping Factor (1kHz, 8Ω) More than 70

Hum & Noise (IHF, Short-circuited, A Network) More than 95dB

Residual Hum & Noise (8Ω, Pre & Power-amplifier) Less than 1mV (0.13 μW)

Subsonic Filter 8Hz (12dB/oct)

PREAMPLIFIER SECTION

Circuitry Equalizer-amplifier 1st Stage Differential Amplifier, 3-stage Direct Coupled SEPP NFB type

Control-amplifier 1st Stage Differential Amplifier, 3-stage Direct Coupled NFB type

Input Sensitivity/Impedance
PHONO 1 2.5mV/50kΩ
PHONO 2 2.5mV~10mV/25kΩ, 50kΩ
100kΩ
PHONO Overload Level (rms/p-p) 250mV/700mV
MIC 2.0mV/50kΩ
TUNER 150mV/100kΩ
AUX 1 150mV/100kΩ
AUX 2 150mV~1.5V/50kΩ~100kΩ
TAPE MONITOR 1, 2 150mV/100kΩ
TAPE MONITOR 2 (DIN connector) 150mV/100kΩ

Output Level/Impedance
TAPE REC 1, 2 150mV
TAPE REC 2 (DIN connector) 30mV/80kΩ
PRE AMP OUT 2V/8Ω

Harmonic Distortion (20Hz~20kHz) Less than 0.03%

Frequency Response
PHONO (RIAA equalization) 30Hz~15kHz ±0.2dB
MIC 10Hz~10kHz ±1dB
TUNER, AUX, TAPE MON 10Hz~70kHz ±1dB

Tone Control
BASS Main Control ±10dB(100Hz)
Sub Control ±6dB(50Hz)
TREBLE Main Control ±10dB(10kHz)
Sub Control ±6dB(20kHz)

Filter
SUBSONIC 8Hz (12dB/oct)
LOW 30Hz (12dB/oct)
HIGH 8kHz, 12kHz (12dB/oct)

Loudness Contour (Volume control set at -40dB position) +10dB (100Hz)

Hum & Noise (IHF, Short-circuited, A Network)
PHONO More than 80dB
MIC More than 70dB
TUNER, AUX, TAPE MON More than 90dB

Muting -20dB
Level Set 0dB, -15dB, -30dB

Miscellaneous

Power Requirements AC 120V 60Hz or AC 110V, 120V, 130V, 220V and 240V 50/60Hz. (Switchable)

Power Consumption (Max.) 430W

AC Outlets Switched 1, Unswitched 2

Dimensions (overall) 430(W) x 138(H) x 341(D)mm
16-15/16(W) x 5-7/16(H) x 13-7/16(D)in.

Weight Without package 13.6kg(29 lb 15oz)
With Package 15.6kg(34 lb 5oz)

Furnished Parts
Connection Cord 1
Polishing Cloth 1
Hex. Wrench 1
Factory-tested Data 1
Operating Instructions 1
5-voltage Model; Fuse 2.5A 1
Fuses 5A 2

NOTE:

Specifications and the design subject to possible modification without notice due to improvements.



3. CONNECTION DIAGRAM

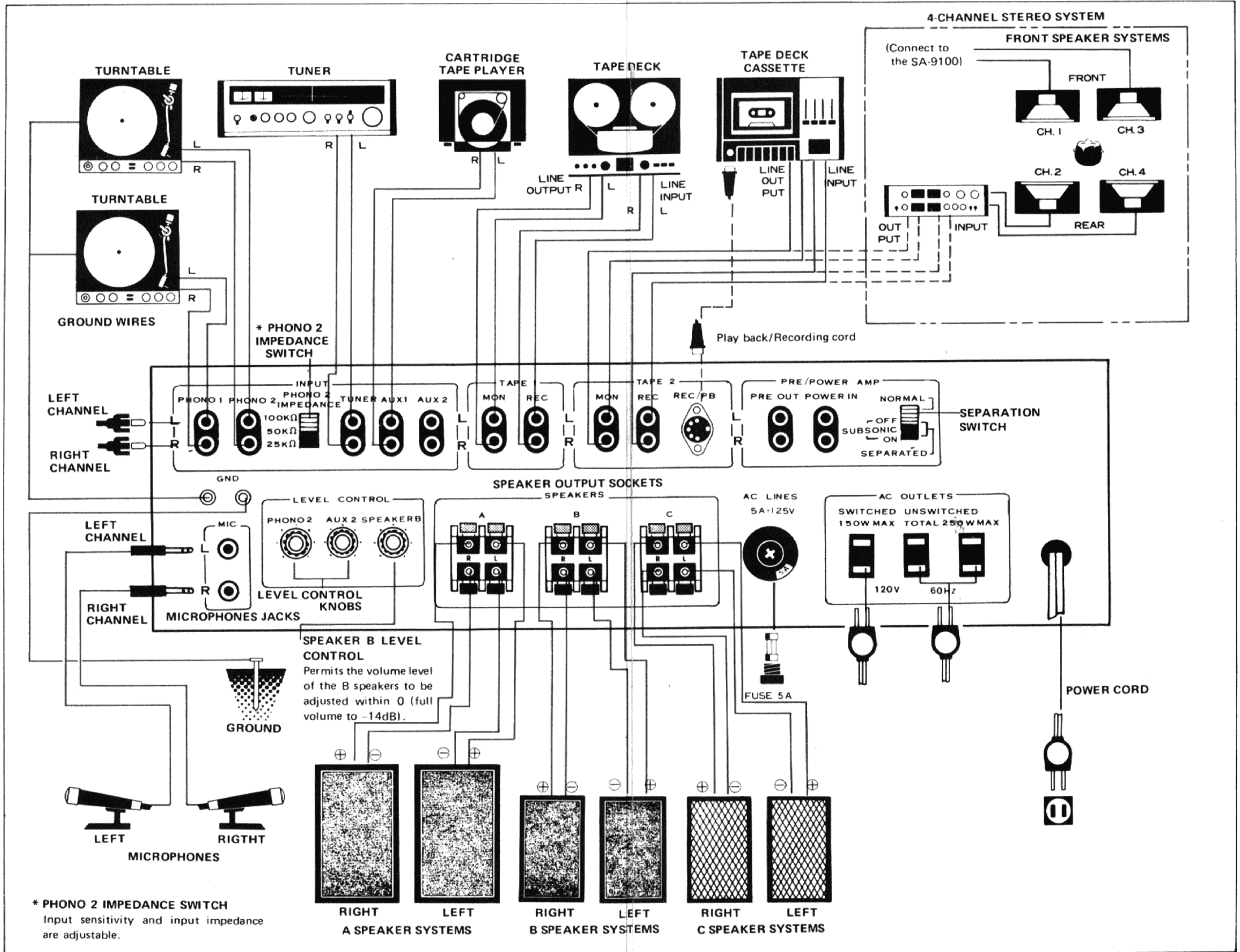

4. FRONT PANEL FACILITIES

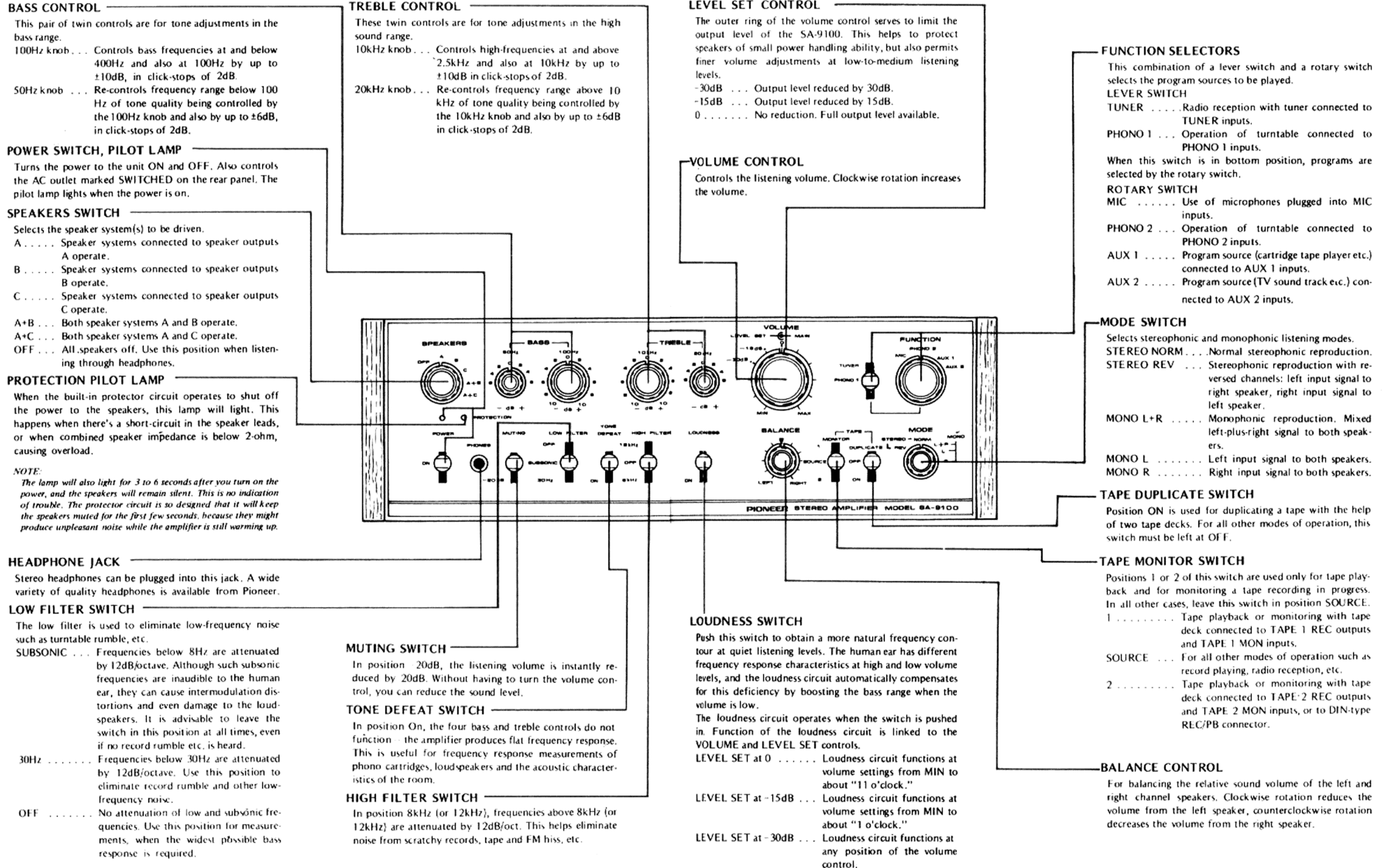

5 BLOCK DIAGRAM

SA-9100

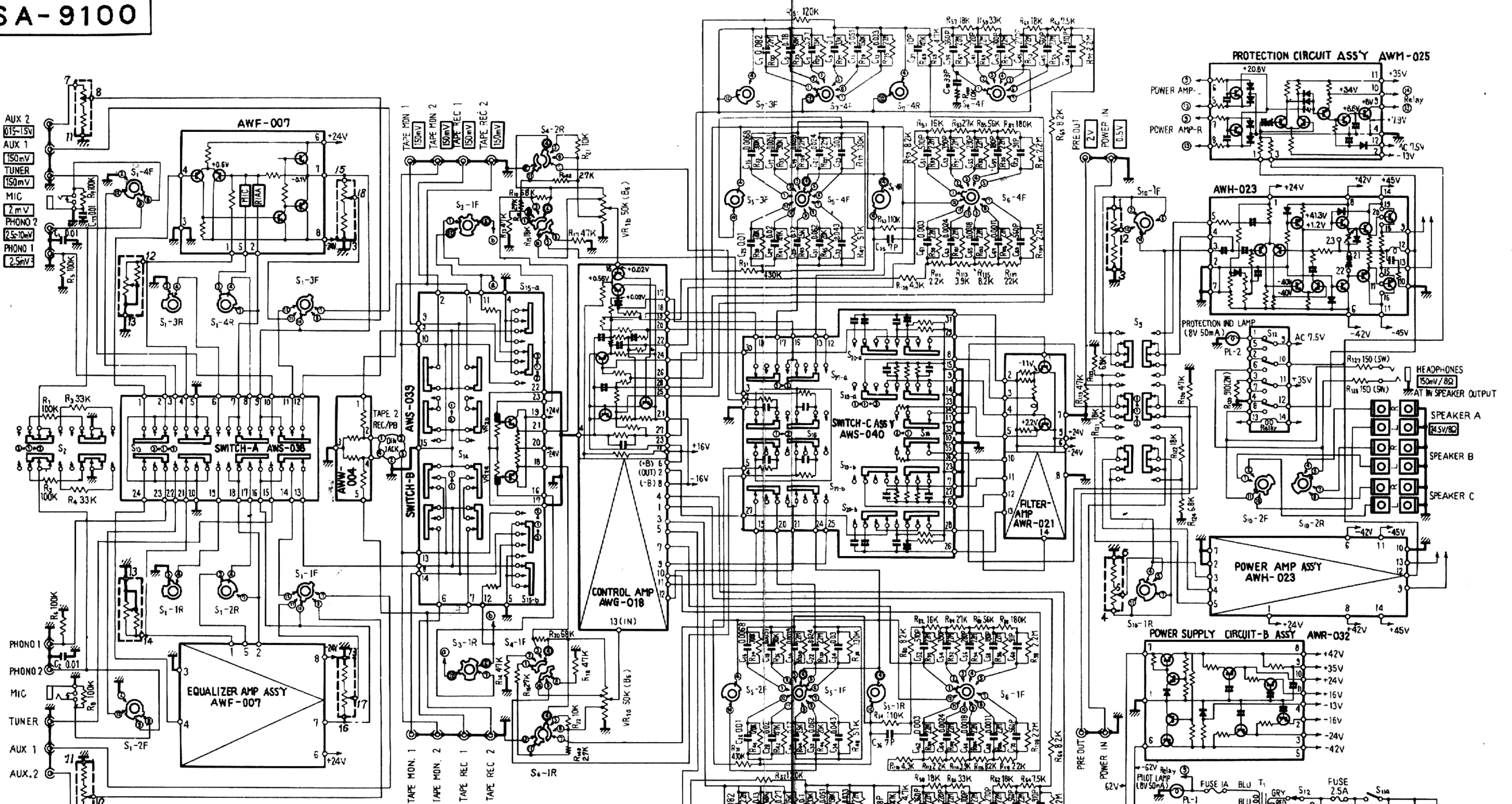

NOTES

- SWITCHES**
- S₁: FUNCTION SELECTOR
 (1) MIC (2) PHONO 2 (3) AUX1 (4) AUX 2
- S₂: PHONO 2 IMPEDANCE SELECTOR
 (1) 50KΩ (2) 25KΩ (3) 100KΩ
- S₃: MODE SELECTOR
 (1) REV (2) NORM (3) L+R (4) L (5) R
- S₄: LEVEL SET
 (1) -30dB (2) -15dB (3) 0dB
- S₅: BASS CONTROL
 (1) -10dB (2) +10dB 2dB step 100Hz
- S₆: TREBLE CONTROL
 (1) -10dB (2) +10dB 2dB step 10kHz
- S₇: BAS CONTROL
 (1) -6dB (2) +6dB 2dB step 50Hz
- S₈: TREBLE CONTROL
 (1) -6dB (2) +6dB 2dB step 20kHz
- S₉: PRE & POWER
 (1) SEPARATED SUBSONIC OFF
 (2) SEPARATED SUBSONIC ON (3) NORMAL
- S₁₀: SPEAKER SELECTOR
 (1) OFF (2) A (3) B (4) C (5) A+B (6) A+C
- S₁₁: POWER
- S₁₂: RELAY
- S₁₃: FUNCTION SELECTOR
 (1) PHONO 1 (2) S₁ (3) TUNER
- S₁₄: DUPLICATE
 (1) OFF (2) ON
- S₁₅: TAPE MONITOR
 (1) SOURCE (2) MON 2 (3) MON 1
- S₁₆: LOUDNESS
 (1) OFF (2) ON
- S₁₇: TONE DEFEAT
 (1) OFF (2) ON
- S₁₈: MUTING
- S₁₉: HIGH FILTER
 (1) OFF (2) 8kHz (3) 12kHz
- S₂₀: LOW FILTER
 (1) SUBSONIC (2) 30Hz (3) OFF
- S₂₁: LINE VOLTAGE SELECTOR
 GRY 240V RED 220V
 ORG 130V BRN 120V
 YEW 110V
- POTENTIOMETERS**
- VR₁: VOLUME CONTROL
 VR₂: BALANCE CONTROL
- RESISTORS**
 IN OHM, 1/4W, ±5% TOLERANCE
 UNLESS OTHERWISE NOTED. K=KΩ, M=MΩ.
- CAPACITORS**
 IN μF UNLESS OTHERWISE NOTED. P=Pf

□ SIGNAL VOLTAGE NECESSARY FOR OBTAINING 15W/8Ω OUTPUT POWER (1kHz).

○ DC VOLTAGE AT NO INPUT SIGNAL.

○ DC CURRENT AT NO INPUT SIGNAL.

--- BROKEN LINE PLOTTED CIRCUITS ARE FOR VOLUME ASSY (AWX-048-0).

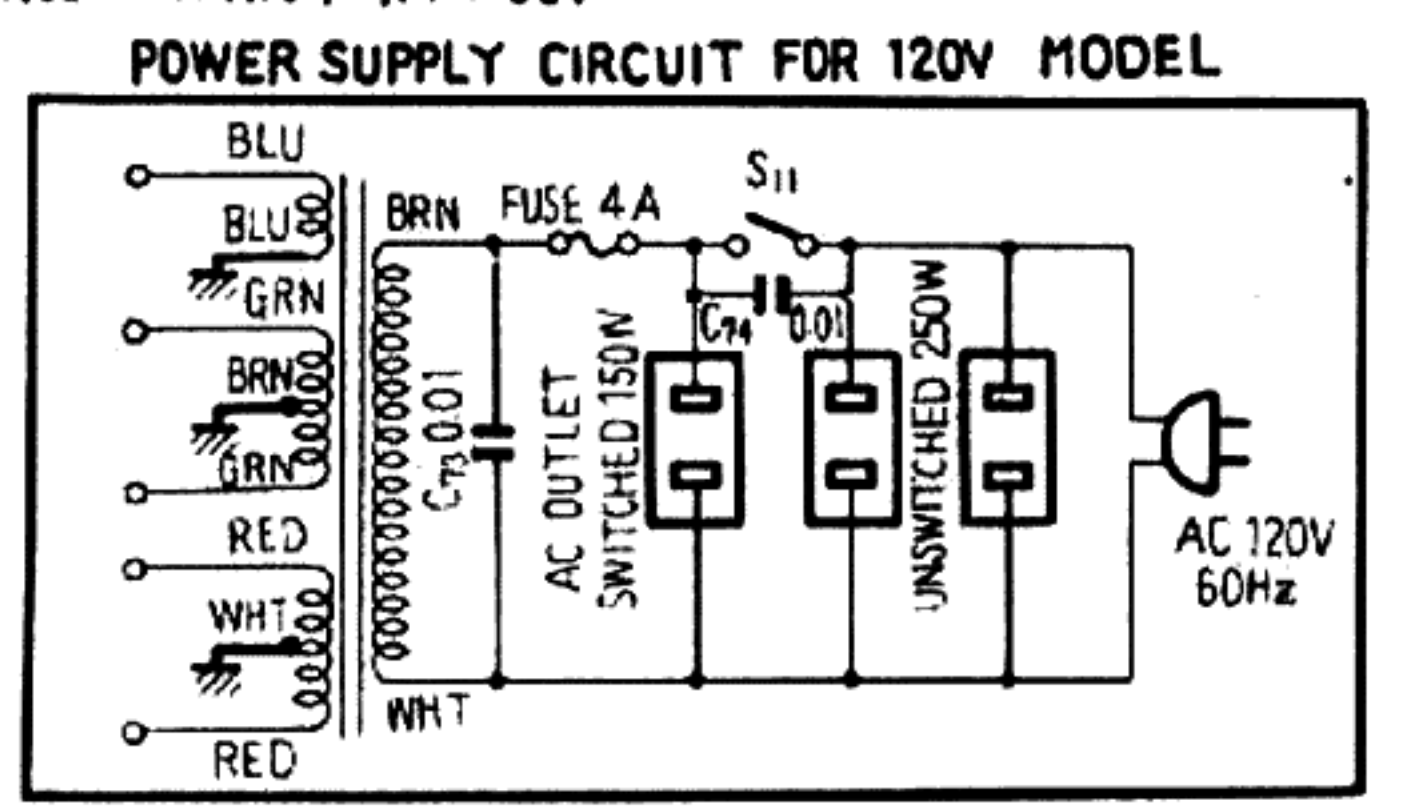

6. CIRCUIT DESCRIPTION

6.1 EQUALIZER AMPLIFIER

The equalizer amplifier is a 3-stage direct coupled single-ended push-pull circuit with a differential amplifier in its first stage. The differential amp transistors (Q1, Q2) are can-sealed type which prevents changes in noise characteristics with the passage of time. The use of a differential amplifier in the first stage permits the application of 100% of DC feedback, resulting in a substantial improvement of DC stability.

By equipping the last stage with a complementary push-pull circuit as commonly used in power amplifiers, power voltage utilization can be improved and output of very low distortion obtained. This design also raises the maximum input handling ability, resulting in a wider dynamic margin.

To assure strict adherence to the RIAA equalization curve, metallized film resistors of $\pm 1\%$ tolerance and styrol capacitors of $\pm 2\%$ tolerance are used. Thus, RIAA deviation remains within $\pm 0.2\text{dB}$ from 30Hz to 15kHz. Gain fluctuations caused by the passage of time are prevented by using a metallized film resistor

of $\pm 1\%$ tolerance at the NFB receiving side.

A variable resistor in series with the dividing resistor for feedback voltage changes the amount of NFB, thus controlling the total gain — this permits phono cartridges of relatively high output voltage to be accommodated without clipping. The phono input circuit has, in other words, more than sufficient dynamic safety margin.

Through the FUNCTION switch the input signal enters the base of Q1. Q1 and Q2 form a differential amplifier. NFB is applied to the base of Q2 to obtain the specified response curve.

R14 is normally grounded, but when the FUNCTION switch is in position PHONO 2, the potentiometer controlled by the LEVEL CONTROL on the rear panel is switched in series into the circuit.

Output from Q1 is amplified in Q3 and then taken out through the A-class complementary circuit formed by Q4 and Q5. A bootstrap circuit is provided to increase the AC load on Q3 and to obtain sufficient loop gain.

EQUALIZER AMP, CIRCUIT SCHEMATIC

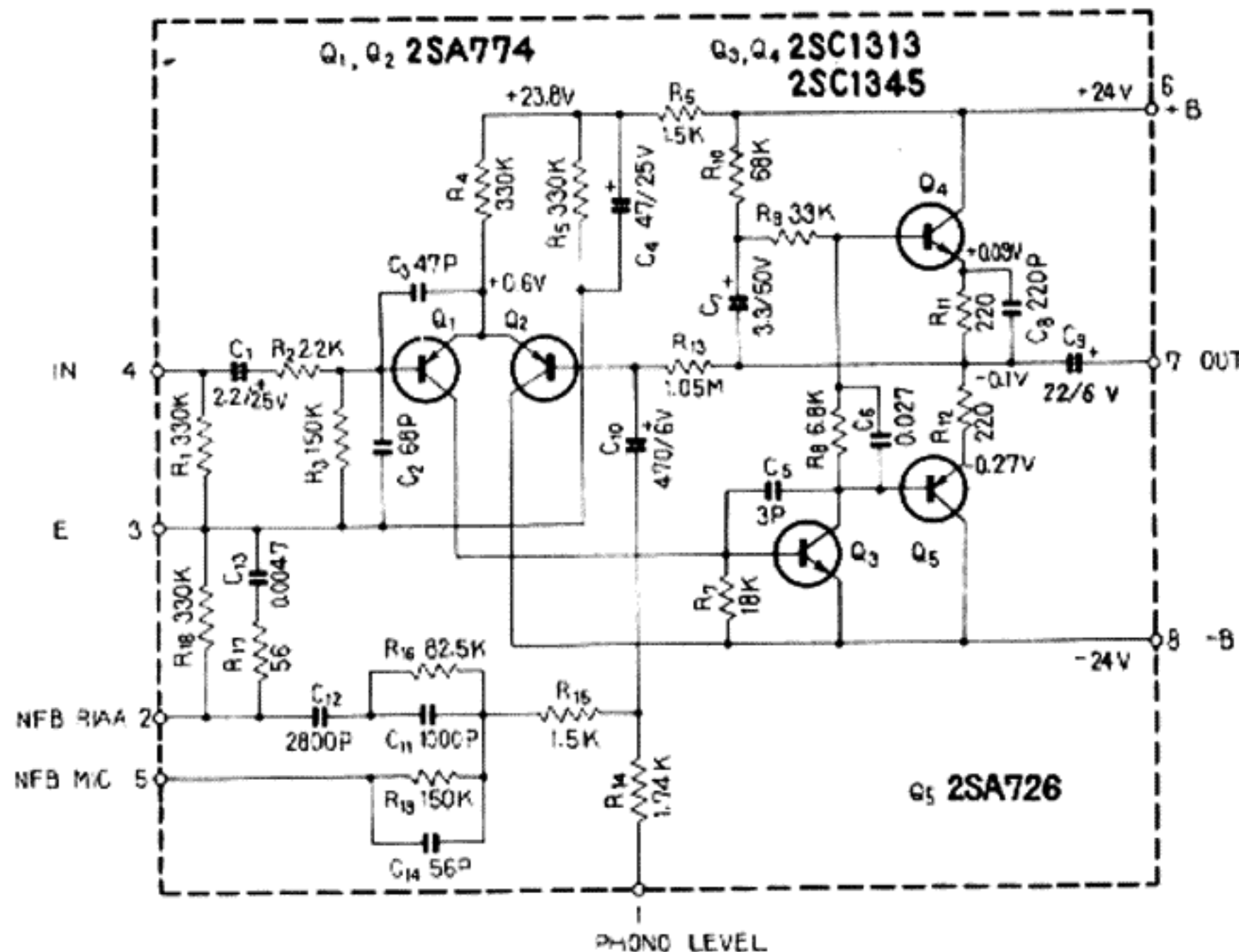

6.2 CONTROL AMPLIFIER

The control amplifier is a 3-stage direct coupled circuit with a differential amp in its initial stage and with so-called "twin tone controls." Adoption of the differential amplifier in the first stage improves DC stability and permits stable higher loop gain operation.

Main as well as sub tone controls operate by switching the CR elements in the feedback path, and precise switching by 2dB steps is possible at all turnover frequencies indicated on

the front panel. In position FLAT, NFB is applied through a resistance only, giving totally flat response characteristics. For accurate and easy system checks and determination of tone control effect, a TONE DEFEAT switch has been provided.

Can-sealed low-noise transistors are used in the first-stage differential amplifier to prevent fluctuations in noise characteristics due to passage of time.

CONTROL AMP, CIRCUIT SCHEMATIC

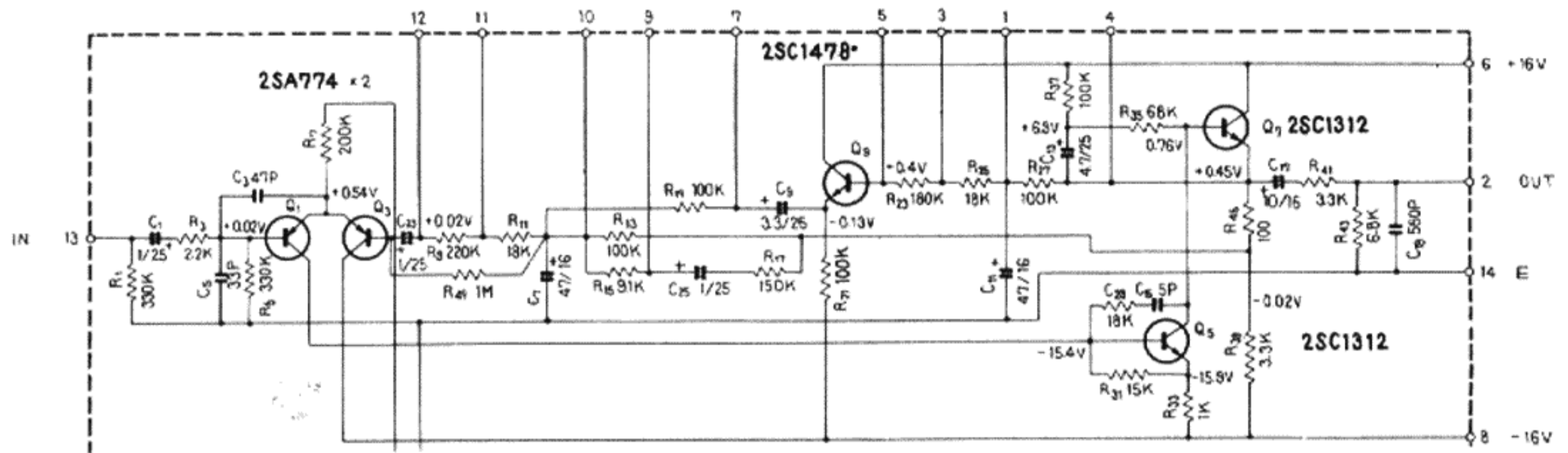

Supply of balanced positive and negative power keeps the DC potential at the inputs and outputs at practically 0V, whereby switching noise is minimized.

The signal from the equalizer amplifier or from the high level input terminals passes through the FUNCTION, TAPE MONITOR, DUPLICATE and MODE switches and through the BALANCE control, then through the emitter-follower in switch circuit-B ass'y and goes to the LEVEL SET switch and VOLUME control.

The LOUDNESS contour circuit is interlocked with the LEVEL SET switch whereby its range of effectiveness is changed; with the LEVEL SET at -30dB , the loudness circuit operates over the whole range of the VOLUME control. After adjustment by the VOLUME control, the signal goes to the base of Q1 on the control amplifier assembly. Q1 and Q3 form a differential amp, and the CR elements for negative feedback, selected by switches, are connected to the base of Q3. Output from this differential amplifier goes from the collector of Q1 to the base of Q5.

The output from Q5 undergoes a change of impedance in the Q7 emitter-follower circuit, then goes to the next stage at low impedance. To assure precise, effective operation of the twin tone controls, an emitter-follower circuit (Q9) has been included between the main and sub controls, preventing mutual interference between these controls.

6.3 FILTER AMPLIFIER

From the control amplifier, the signal passes through low cut and high cut filters where unwanted portions are filtered out, and then enters the power amplifier. The low cut filter, with Q1, provides 12dB/oct. cut-off at either 30Hz or 8Hz (SUBSONIC). The high cut filter uses an LC network for 12dB/oct. cut-off at 8kHz or 12kHz frequency.

6.4 POWER AMPLIFIER

The power amplifier is a pure complementary direct coupled OCL design with two differential amplification stages. The two-stage differential amplifier and the bias compensation circuit result in extremely good DC stability, preventing practically completely any generation of DC potential at the output junction caused by changes in the operating ambient temperature. Moreover, constant-current circuits are included at two stages to prevent changes in idle current due to AC line voltage fluctuations, which in turn precludes the generation of transient crossover distortions. Because of the 3-stage quasi-Darlington circuit provided with the constant-current drive, the predriver (Q3) operation could be help, distortion decreased and relatively high loop gain obtained. In both the driver and last stages, special PNP and NPN transistors of precisely matched characteristics are employed. Left and right channel circuits are not combined on one circuit board but are separated into two monophonic amplifiers. This not only improves heat dissipation but also prevents inequality in ultra-high frequency response caused by slight differences in the PC Boards copper film conductor pattern. Utmost operational safety is assured by using transistors of very high strength, by providing large-sized heat sinks, by including a current limiter circuit, and by installing an electronic protection circuit. The input signal enters the base of Q1. AC and DC negative feedback is applied to the base of Q2. The balanced output from the collectors of Q1 and Q2 enters the bases of Q3

and Q4 (the differential amplifier), respectively. The constant-current circuit (Q5) and the input impedance of the emitter-follower (Q6) reduce the operating load on Q3.

The signal from Q3 undergoes current amplification in Q6 and is then power-amplified in the output stages Q8~Q11. The emitter side load of Q6 is maintain to high impedance by the constant-current circuit formed by Q7.

DC negative feedback from the output junction is applied to the base of Q2 through R33, R34 and R35, while AC NFB goes to the base of Q2 through R33 and R35.

To maintain DC potential at the output junction at 0V, a bias circuit formed by D1, R6, R7, R8, R9, R10 and VR1 is provided. D1 is included for perfect temperature compensation. The idle current limiter circuit is formed by VR4 and D4. Varistor D4 consists of four diode unit analog to the V_{BE} of the driver and power transistors and to their temperature characteristics. Diode D3, in parallel with VR2, acts as protection if, by some trouble, VR2 should become non-conductive. D6 is a current limiting diode protecting against excessively high input.

To improve stability in the high-frequency range, high range phase compensation is performed by the following circuit: C4, C7, R14, C8, R15, C9, C11, R31, L1 and R32. C10, by providing a smooth outlet for the base storage carrier of Q10 and Q11, reduces high range notching distortion, thereby improving overall distortion characteristics.

POWER AMP, CIRCUIT SCHEMATIC

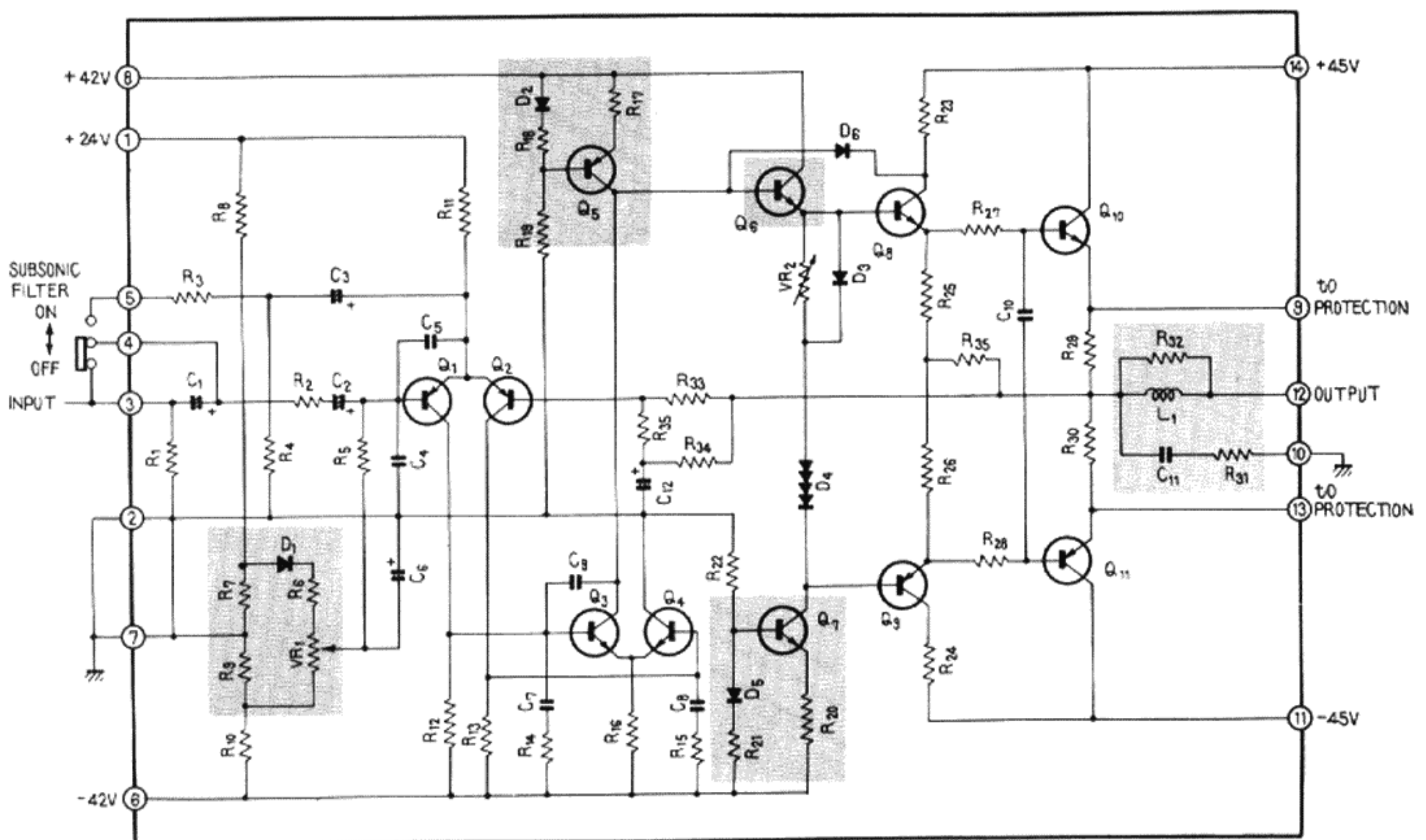

R23, R27, R24 and R28 are protective resistors which limit current flow under low-load conditions.

Output from the power amplifier passes through the relay points and the SPEAKERS switch to the speaker output terminals and the headphone jack.

6.5 PROTECTION CIRCUIT

The protection circuit comprises 7 transistors. Of these, Q1 and Q2 serve to detect excessive current in the power amplifier and short-circuiting of the output load (speaker leads, etc.). Each transistor serves one channel.

Q3 and Q4, constituting a differential amplifier, detect DC potential at the power amplifier output; this circuit is common for both channels. Transistors Q5 to Q7 are the relay driving circuit. When the power switch is turned off, negative voltage is applied to the base of Q6 to open the relay smoothly.

And CR time constant circuit is connected to the base of Q7. This mutes the output immediately upon switch-on and controls the reset time of the relay.

6.6 POWER SUPPLY CIRCUIT

All circuits — with the exception of the protection circuit — are supplied with balanced positive and negative power, which substantially improves operating stability. There are two sets of bridged rectifier circuits for this purpose. One set exclusively supplies the power amplifier. After rectification, ripple voltage takes off by through a $15,000\mu\text{F}$ capacitor. The other rectifier set supplies all other circuits with power. After rectification, voltage stabilization and passage through a ripple filter, power is supplied with low impedance.

7. DISASSEMBLY

1. To remove the wooden case, remove the two screws on either side, then lift the back end of the case upward.
2. Pull off all control knobs. The LEVEL SET knob must be first loosened with a hex. wrench.
3. Remove the three screws each from the top and bottom edges of the front panel, then gently pull the panel forward.
4. To remove the bottom panel, first remove the 9 screws holding it in place.
5. Adjustment procedures

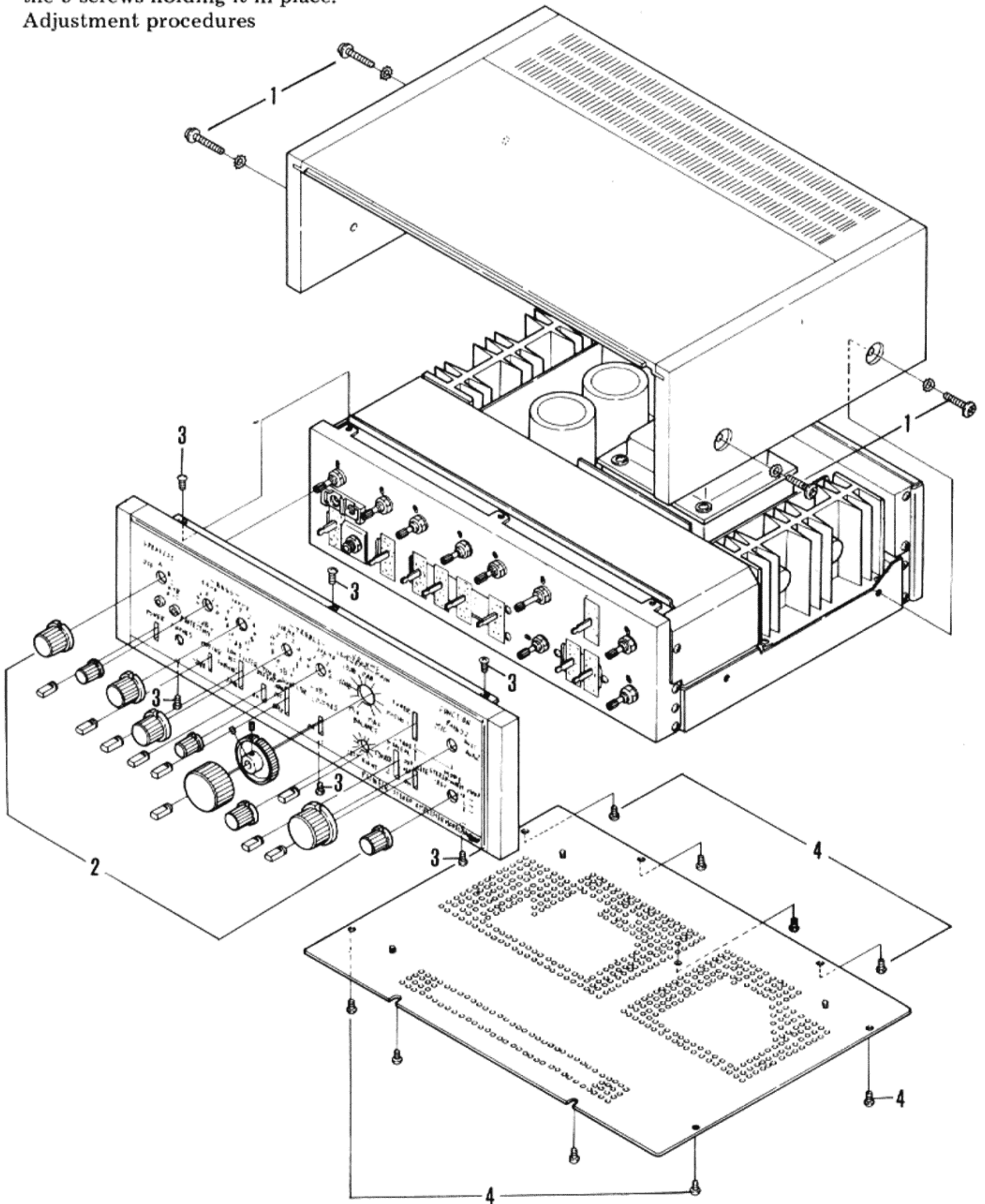

8. PARTS AND P.C. BOARD LOCATION

8.1 TOP VIEW

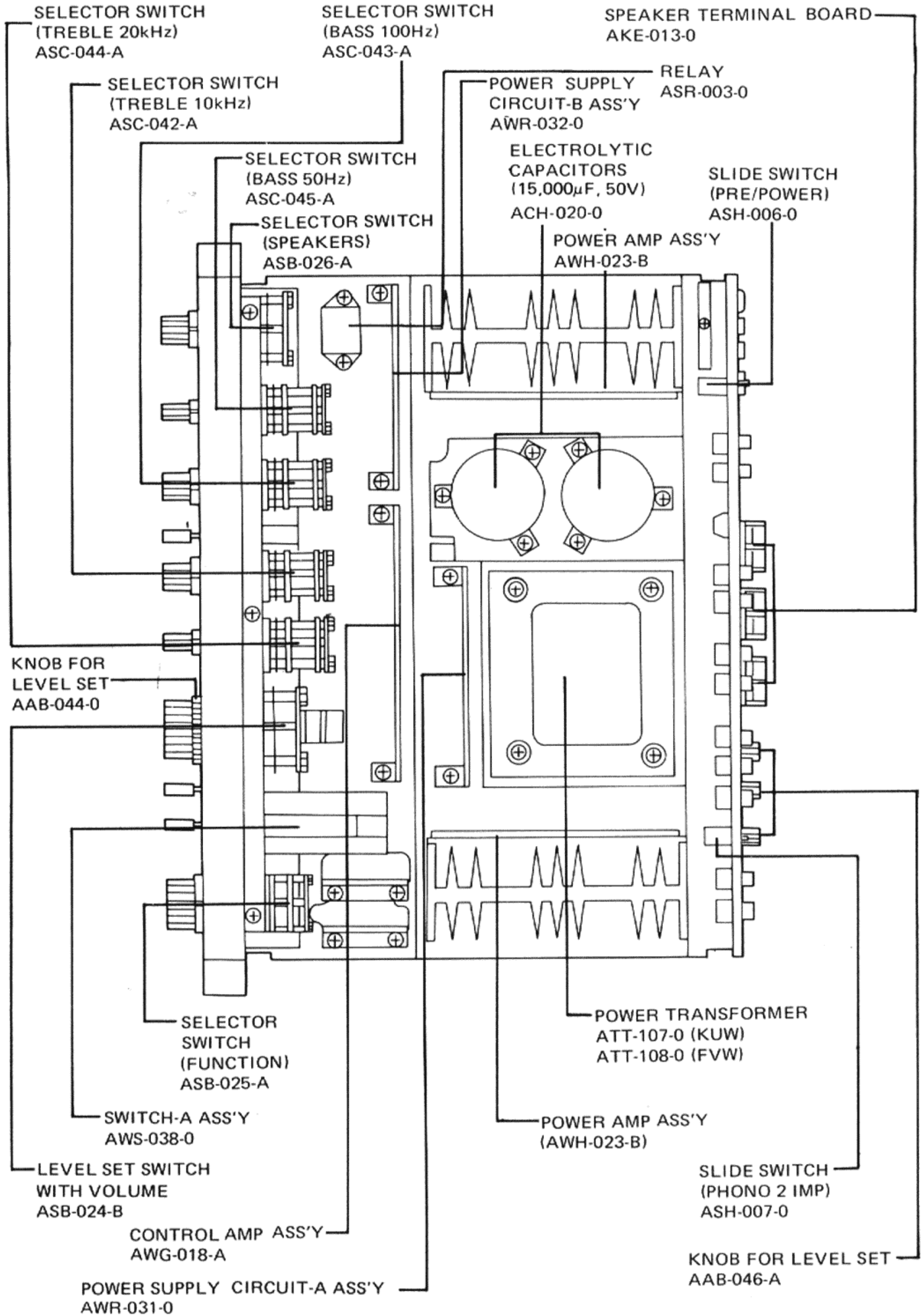

8.2 BOTTOM VIEW

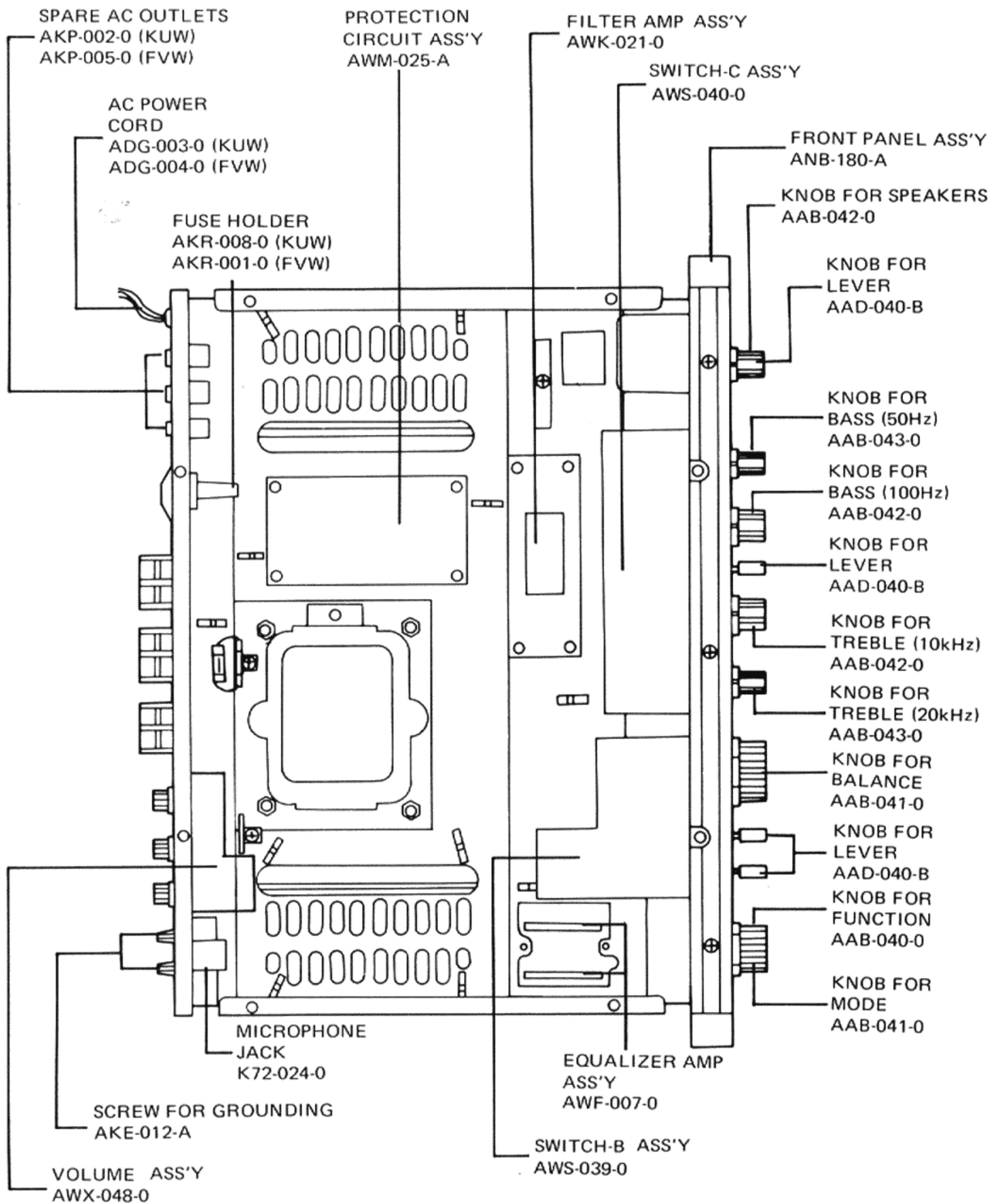

9. ALIGNMENT PROCEDURE

The SA-9100 has two separate power amp boards. As viewed from the front, the left circuit board is the left channel power amp, the right circuit board, is the right channel power amp.

Adjustment procedures are identical for both channels, so the explanations below are given for one channel only. All adjustments are required to be made on both channels, however.

9.1 IDLE CURRENT ADJUSTMENT

1. Remove output load. Without applying input, terminate input terminals (terminals no.3) with $4.7\text{ k}\Omega$ resistance.
2. Set VR1 at approximately center position, turn VR3 all the way counterclockwise. Then turn on power

3. Allow approximately 20 minutes warm-up time. Then adjust VR3 to obtain a voltage reading of 25mV between terminals no. 9 and 13.

9.2 ADJUSTMENT OF NEUTRAL POTENTIAL

1. Remove output load. Terminate input terminals of circuit board with $4.7\text{ k}\Omega$ resistance, then turn on power.
2. Allow approximately 20 minutes warm-up time. Then adjust VR1 to obtain a voltage reading of $0\text{V} \pm 10\text{mV}$ between terminal no. 23 and ground.

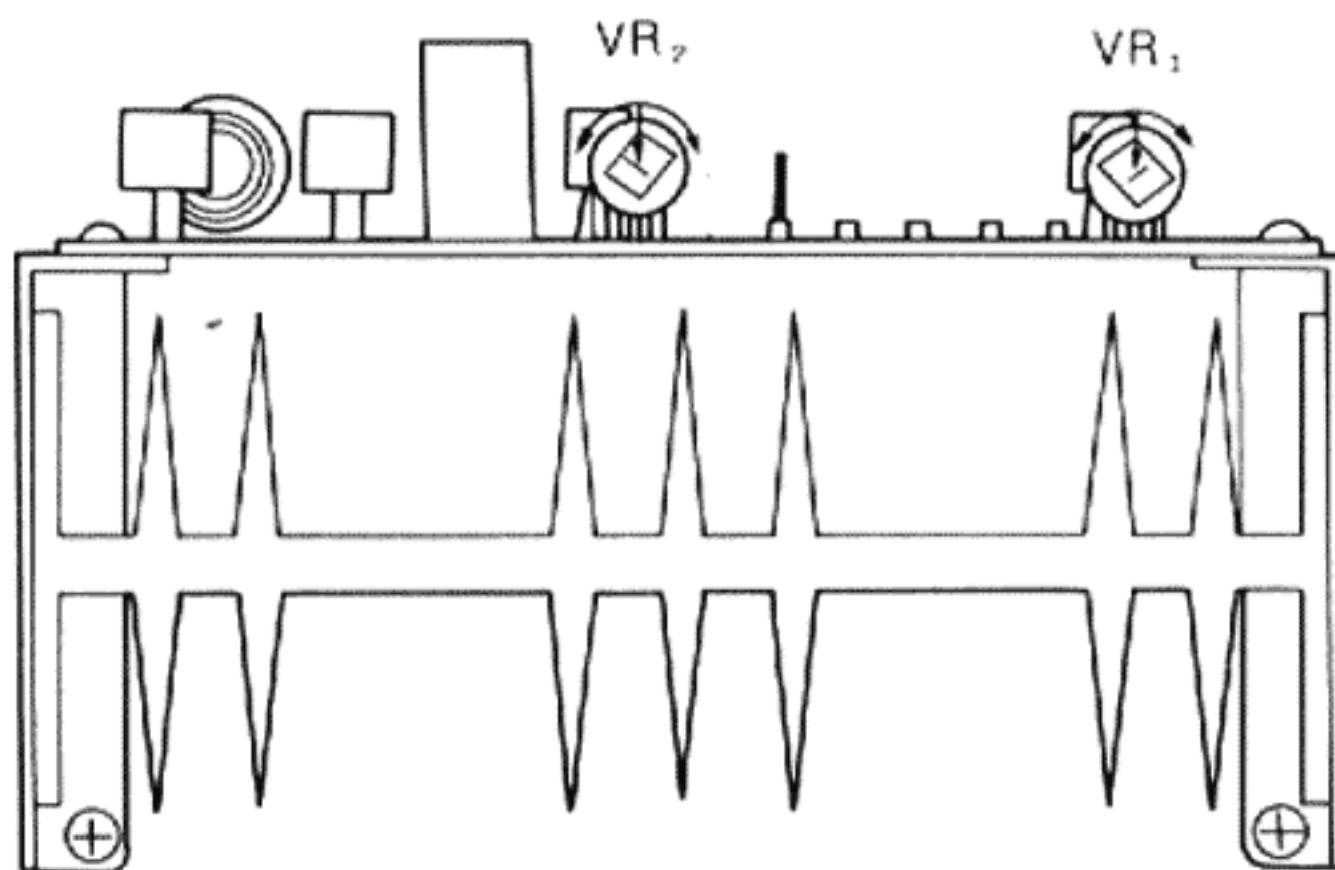

10. EXPLODED VIEW AND PARTS LIST

Parts List of Exploded View

NOTICE:

Any parts asterisked * are subject to being not supplied.

Key No.	Description	Part No.	
1*	Front shield cover	ANH-133-0	
2	Power amp ass'y	AWH-023-B	
3	Power transformer for KUW model	ATT-107-0	
	Power transformer for FVW model	ATT-108-0	
4*	Rear shield cover	ANH-119-0	
5	Power amp ass'y	AWH-023-B	
6*	4P terminal strip	AKC-021-0	
7	Electrolytic capacitor 15,000 μ F 50V	ACH-020-0	
8	Electrolytic capacitor 15,000 μ F 50V	AGH-020-0	
9	Power supply circuit-A ass'y	AWR-031-0	
10	Power supply circuit-B ass'y	AWR-032-0	
11	Control amp ass'y	AWG-018-A	
12*	Wire clip-A	AEC-004-0	
13	Relay	ASR-003-0	
14	AC power cord for KUW model	ADG-003-0	
	AC power cord for FVW model	ADG-004-0	
15*	AC cord stopper	AEC-079-0	
16	5P connector (DIN type)	K93-003-B	
17*	Switch stopper	AEC-086-0	
18	Knob for level control	AAB-046-A	
19	Screw for grounding	AKE-012-A	
20*	Rear panel	ANC-074-0	
21	Slide switch (PRE/POWER)	ASH-006-0	
22	Spare AC outlet for KUW model	AKP-002-0	
	Spare AC outlet for FVW model	AKP-005-0	
23	Fuse holder for KUW model	AKR-008-0	
	Fuse holder for FVW model	AKR-001-0	
24	Speaker terminal board (triple type)	AKE-013-0	
25	Six fold phono jack-B	AKB-017-0	
26	Slide switch (PHONO 2 IMP)	ASH-007-0	
27	Four-fold phono Jack-B	AKB-015-0	
28	Four-fold phono jack-A	AKB-014-0	
29	Four-fold phono jack-A	AKB-014-0	
30	Microphone jack	K72-024-0	
31	Volume ass'y	AWX-048-0	
32	Equalizer amp ass'y	AWF-007-0	
33*	Chassis	ANA-036-B	
34*	Boss	AEB-019-0	
35	Protection circuit ass'y	AWM-025-A	
36	Filter amp ass'y	AWK-021-0	
37*	4P ground terminal	K13-047-0	
38	Selector switch (MODE)	ASB-022-A	
39	Selector switch (FUNCTION)	ASB-025-A	
40*	2P terminal strip	AKC-015-0	

Symbol	Description	Part No.	
41	Switch-A ass'y	AWS-038-0	
42	LEVEL SET switch with VOLUME	ASB-024-B	
43*	4P terminal strip	AKC-021-0	
44	Selector switch (TREBLE 20kHz)	ASC-044-A	
45	Selector switch (TREBLE 10kHz)	ASC-042-A	
46	Selector switch (BASS 100Hz)	ASC-043-A	
47	Selector switch (BASS 50Hz)	ASC-045-A	
48	Selector switch (SPEAKERS)	ASB-026-A	
49	Pilot lamp for indicator	AEL-007-0	
50	Pilot lamp for protection	AEL-014-0	
51*	Cushion	AEB-030-0	
52*	Light shade	AED-018-0	
53	Headphone jack	K72-026-0	
54	Lever switch (POWER) for KUW model	ASK-039-0	
	Lever switch (POWER) for FVW model	ASK-040-0	
55	Switch-C ass'y	AWS-040-0	
56	Switch-B ass'y	AWS-039-0	
57*	Wire clip-D	AEC-024-0	
58*	Shield cover	ANH-148-0	
59*	Shield board	ANH-138-0	

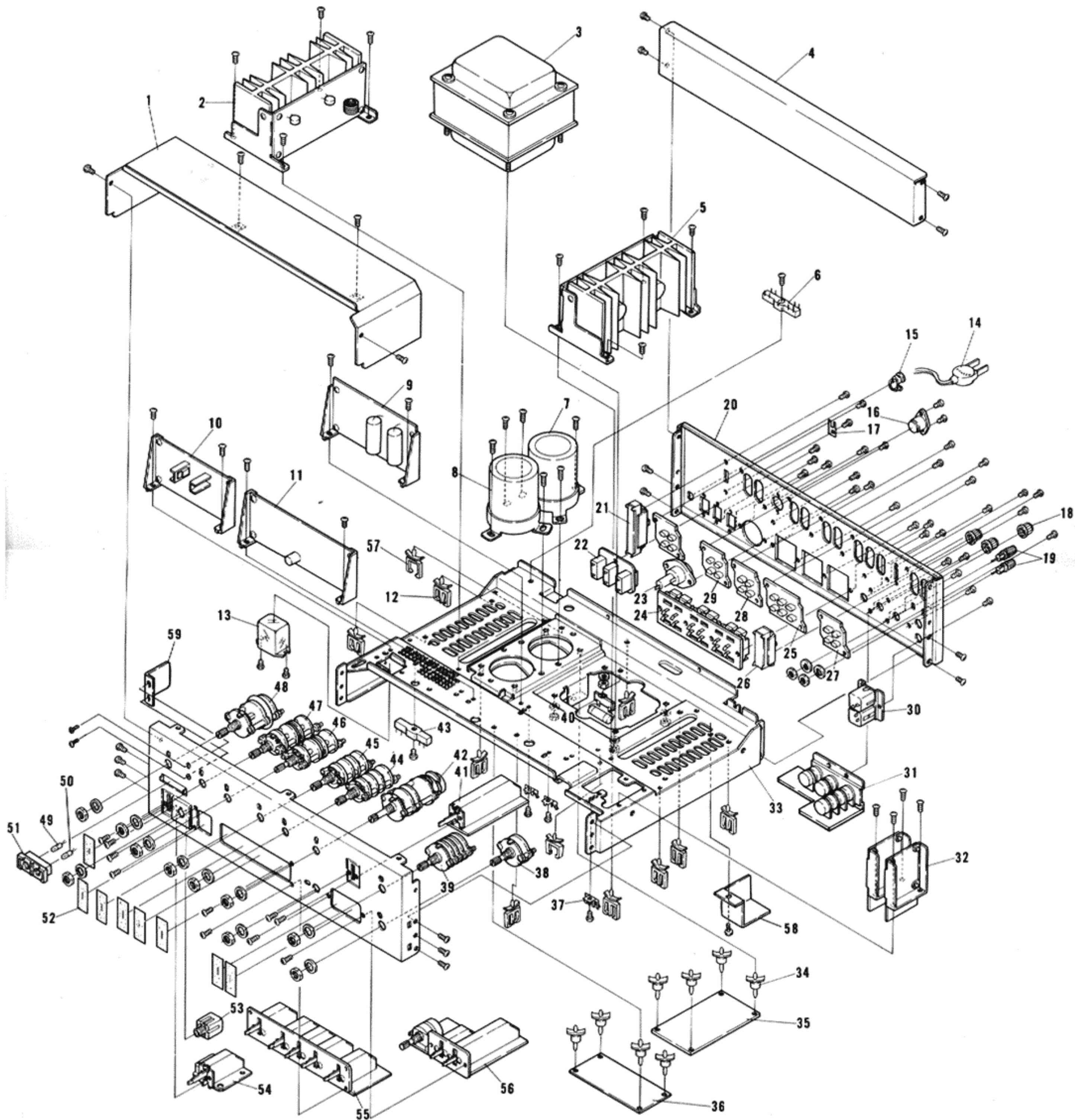

1.1 CIRCUIT CONNECTION DIAGRAM AND MISCELLANEOUS PARTS

SA-9100

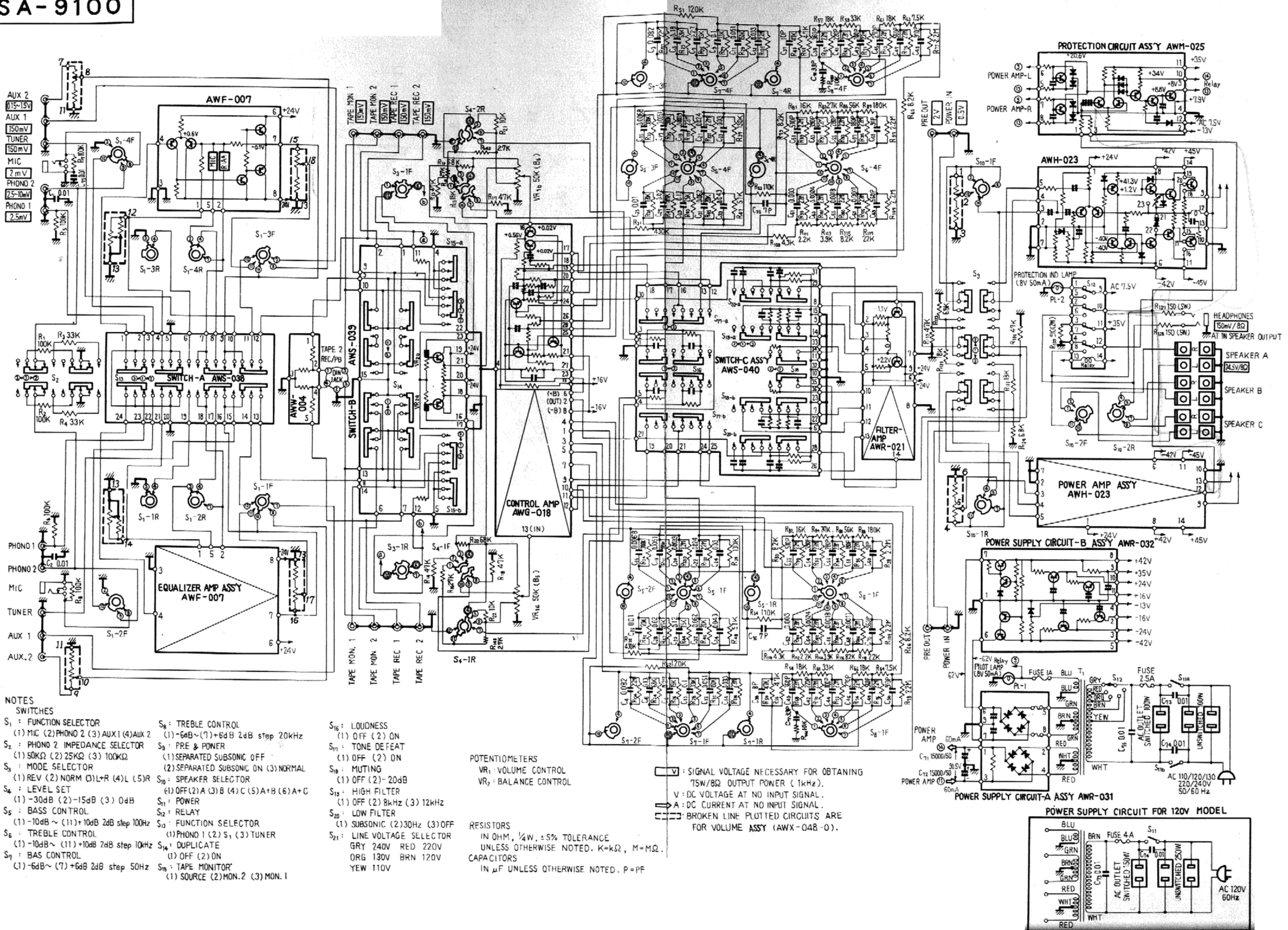

- CAPACITORS: IN μ F UNLESS OTHERWISE NOTED p: pF
- RESISTORS: IN Ω , $\frac{1}{4}$ W UNLESS OTHERWISE NOTED k: k Ω , M: M Ω

Miscellaneous Parts List

CAPACITORS

Symbol	Description	Part No.
C1	Ceramic 0.01 50V	CKDYF 103Z 50
C2	Ceramic 0.01 50V	CKDYF 103Z 50
C3	Mylar 0.082 50V	CQMA 823J 50
C4	Mylar 0.082 50V	CQMA 823J 50
C5	Mylar 0.13 50V	CQMA 134J 50
C6	Mylar 0.13 50V	CQMA 134J 50
C7	Mylar 0.27 50V	CQMA 274J 50
C8	Mylar 0.27 50V	CQMA 274J 50
C9	Mylar 0.1 50V	CQMA 104J 50
C10	Mylar 0.1 50V	CQMA 104J 50
C11	Mylar 0.051 50V	CQMA 513J 50
C12	Mylar 0.051 50V	CQMA 513J 50
C13	Mylar 0.033 50V	CQMA 333J 50
C14	Mylar 0.033 50V	CQMA 333J 50
C15	Mylar 0.0068 50V	CQMA 682J 50
C16	Mylar 0.0068 50V	CQMA 682J 50
C17	Mylar 0.0051 50V	CQMA 512J 50
C18	Mylar 0.0051 50V	CQMA 512J 50
C19	Mylar 0.0039 50V	CQMA 392J 50
C20	Mylar 0.0039 50V	CQMA 392J 50
C21	Mylar 0.024 50V	CQMA 243J 50
C22	Mylar 0.024 50V	CQMA 243J 50
C23	Mylar 0.03 50V	CQMA 303J 50
C24	Mylar 0.03 50V	CQMA 303J 50
C25	Mylar 0.01 50V	CQMA 103J 50
C26	Mylar 0.01 50V	CQMA 103J 50
C27	Mylar 0.02 50V	CQMA 203J 50
C28	Mylar 0.02 50V	CQMA 203J 50
C29	Mylar 0.12 50V	CQMA 124J 50
C30	Mylar 0.12 50V	CQMA 124J 50
C31	Mylar 0.062 50V	CQMA 623J 50
C32	Mylar 0.062 50V	CQMA 623J 50
C33	Mylar 0.043 50V	CQMA 433J 50
C34	Mylar 0.043 50V	CQMA 433J 50
C35	Ceramic 7p 50V	CCDSL 070F 50
C36	Ceramic 7p 50V	CCDSL 070F 50
C37	Ceramic 10p 50V	CCDSL 100F 50
C38	Ceramic 8p 50V	CCDSL 080F 50
C39	Styrol 360p 50V	CQSB 361J 50
C40	Styrol 360p 50V	CQSB 361J 50
C41	Styrol 220p 50V	CQSB 221J 50
C42	Styrol 220p 50V	CQSB 221J 50
C43	Styrol 100p 50V	CQSB 101J 50
C44	Styrol 100p 50V	CQSB 101J 50
C45	Styrol 270p 50V	CQSB 271J 50

Symbol	Description	Part No.	
C46	Styrol 270p 50V	CQSB 271J 50	
C47	Styrol 560p 50V	CQSB 561J 50	
C48	Styrol 560p 50V	CQSB 561J 50	
C49	Styrol 910p 50V	CQSB 911J 50	
C50	Styrol 910p 50V	CQSB 911J 50	
C51	Styrol 510p 50V	CQSB 511J 50	
C52	Styrol 510p 50V	CQSB 511J 50	
C53	Styrol 390p 50V	CQSB 391J 50	
C54	Styrol 390p 50V	CQSB 391J 50	
C55	Styrol 280p 50V	CQSB 281J 50	
C56	Styrol 280p 50V	CQSB 281J 50	
C57	Styrol 180p 50V	CQSB 181J 50	
C58	Styrol 180p 50V	CQSB 181J 50	
C59	Styrol 91p 50V	CQSB 910J 50	
C60	Styrol 91p 50V	CQSB 910J 50	
C61	Mylar 0.003 50V	CQMA 302J 50	
C62	Mylar 0.003 50V	CQMA 302J 50	
C63	Mylar 0.0024 50V	CQMA 242J 50	
C64	Mylar 0.0024 50V	CQMA 242J 50	
C65	Mylar 0.0018 50V	CQMA 182J 50	
C66	Mylar 0.0018 50V	CQMA 182J 50	
C67	Mylar 0.0011 50V	CQMA 112J 50	
C68	Mylar 0.0011 50V	CQMA 112J 50	
C69	Styrol 560p 50V	CQSB 561J 50	
C70	Styrol 560p 50V	CQSB 561J 50	
C71	Electrolytic 15,000 50V	ACH-020-0	
C72	Electrolytic 15,000 50V	ACH-020-0	
C73	Metallized mylar 0.01 800V	ACE-002-0	KUW model
	Ceramic 0.01 1.4kV	C43-003-0	FVW model
C74	Ceramic 0.01 150V	ACG-002-0	KUW model
	Ceramic 0.01 1.4kV	C43-003-0	FVW model
C75	Ceramic 0.01 50V	CKDYF 103Z 50	
C76	Ceramic 0.01 1.4kV	C43-003-0	FVW model
C77	Ceramic 33p 50V	CCDSL 330K 50	
C78	Ceramic 33p 50V	CCDSL 330K 50	

RESISTORS

Symbol	Description	Part No.	
R1	Carbon film 100k	RD¼PM 104J	
R2	Carbon film 100k	RD¼PM 104J	
R3	Carbon film 33k	RD¼PM 333J	
R4	Carbon film 33k	RD¼PM 333J	
R5	Carbon film 100k	RD¼PM 104J	
R6	Carbon film 100k	RD¼PM 104J	
R7	Carbon film 100k	RD¼PM 104J	
R8	Carbon film 100k	RD¼PM 104J	
R13	Carbon film 47k	RD¼PM 473J	
R14	Carbon film 47k	RD¼PM 473J	
R15	Carbon film 18k	RD¼PM 183J	

Symbol	Description	Part No.
R16	Carbon film 18k	RD¼PM 183J
R17	Carbon film 47k	RD¼PM 473J
R18	Carbon film 47k	RD¼PM 473J
R19	Carbon film 68k	RD¼PM 683J
R20	Carbon film 68k	RD¼PM 683J
R21	Carbon film 10k	RD¼PM 103J
R22	Carbon film 10k	RD¼PM 103J
R23	Carbon film 68k	RD¼PM 683J
R24	Carbon film 68k	RD¼PM 683J
R25	Carbon film 15k	RD¼PM 153J
R26	Carbon film 15k	RD¼PM 153J
R27	Carbon film 33k	RD¼PM 333J
R28	Carbon film 33k	RD¼PM 333J
R29	Carbon film 150k	RD¼PM 154J
R30	Carbon film 150k	RD¼PM 154J
R31	Carbon film 430k	RD¼PM 434J
R32	Carbon film 430k	RD¼PM 434J
R33	Carbon film 300k	RD¼PM 304J
R34	Carbon film 300k	RD¼PM 304J
R35	Carbon film 910k	RD¼PM 914J
R36	Carbon film 910k	RD¼PM 914J
R37	Carbon film 130k	RD¼PM 134J
R38	Carbon film 130k	RD¼PM 134J
R39	Carbon film 120k	RD¼PM 124J
R40	Carbon film 120k	RD¼PM 124J
R41	Carbon film 47k	RD¼PM 473J
R42	Carbon film 47k	RD¼PM 473J
R43	Carbon film 7.5k	RD¼PM 752J
R44	Carbon film 7.5k	RD¼PM 752J
R45	Carbon film 20k	RD¼PM 203J
R46	Carbon film 20k	RD¼PM 203J
R47	Carbon film 51k	RD¼PM 513J
R48	Carbon film 51k	RD¼PM 513J
R49	Carbon film 47k	RD¼PM 473J
R50	Carbon film 47k	RD¼PM 473J
R51	Carbon film 120k	RD¼PM 124J
R52	Carbon film 120k	RD¼PM 124J
R53	Carbon film 110k	RD¼PM 114J
R54	Carbon film 110k	RD¼PM 114J
R55	Carbon film 4.7k	RD¼PM 472J
R56	Carbon film 4.7k	RD¼PM 472J
R57	Carbon film 18k	RD¼PM 183J
R58	Carbon film 18k	RD¼PM 183J
R59	Carbon film 33k	RD¼PM 333J
R60	Carbon film 33k	RD¼PM 333J
R61	Carbon film 18k	RD¼PM 183J
R62	Carbon film 18k	RD¼PM 183J
R63	Carbon film 7.5k	RD¼PM 752J
R64	Carbon film 7.5k	RD¼PM 752J
R65	Carbon film 8.2k	RD¼PM 822J

Symbol	Description	Part No.
R66	Carbon film 8.2k	RD¼PM 822J
R67	Carbon film 2.2M	RD¼PM 225J
R68	Carbon film 2.2M	RD¼PM 225J
R69	Carbon film 2.2M	RD¼PM 225J
R70	Carbon film 2.2M	RD¼PM 225J
R71	Carbon film 2.2M	RD¼PM 225J
R72	Carbon film 2.2M	RD¼PM 225J
R73	Carbon film 2.2M	RD¼PM 225J
R74	Carbon film 2.2M	RD¼PM 225J
R75	Carbon film 2.2M	RD¼PM 225J
R76	Carbon film 2.2M	RD¼PM 225J
R77	Carbon film 2.2M	RD¼PM 225J
R78	Carbon film 2.2M	RD¼PM 225J
R79	Carbon film 8.2k	RD¼PM 822J
R80	Carbon film 8.2k	RD¼PM 822J
R81	Carbon film 16k	RD¼PM 163J
R82	Carbon film 16k	RD¼PM 163J
R83	Carbon film 27k	RD¼PM 273J
R84	Carbon film 27k	RD¼PM 273J
R85	Carbon film 56k	RD¼PM 563J
R86	Carbon film 56k	RD¼PM 563J
R87	Carbon film 180k	RD¼PM 184J
R88	Carbon film 180k	RD¼PM 184J
R89	Carbon film 2.2M	RD¼PM 225J
R90	Carbon film 2.2M	RD¼PM 225J
R91	Carbon film 2.2M	RD¼PM 225J
R92	Carbon film 2.2M	RD¼PM 225J
R93	Carbon film 2.2M	RD¼PM 225J
R94	Carbon film 2.2M	RD¼PM 225J
R95	Carbon film 2.2M	RD¼PM 225J
R96	Carbon film 2.2M	RD¼PM 225J
R97	Carbon film 2.2M	RD¼PM 225J
R98	Carbon film 2.2M	RD¼PM 225J
R99	Carbon film 2.2M	RD¼PM 225J
R100	Carbon film 2.2M	RD¼PM 225J
R101	Carbon film 2.2M	RD¼PM 225J
R102	Carbon film 2.2M	RD¼PM 225J
R103	Carbon film 2.2M	RD¼PM 225J
R104	Carbon film 2.2M	RD¼PM 225J
R105	Carbon film 2.2M	RD¼PM 225J
R106	Carbon film 2.2M	RD¼PM 225J
R107	Carbon film 2.2M	RD¼PM 225J
R108	Carbon film 2.2M	RD¼PM 225J
R109	Carbon film 4.3k	RD¼PM 432J
R110	Carbon film 4.3k	RD¼PM 432J
R111	Carbon film 2.2k	RD¼PM 222J
R112	Carbon film 2.2k	RD¼PM 222J
R113	Carbon film 3.9k	RD¼PM 392J
R114	Carbon film 3.9k	RD¼PM 392J
R115	Carbon film 8.2k	RD¼PM 822J

Symbol	Description	Part No.
R116	Carbon film 8.2k	RD¼PM 822J
R117	Carbon film 22k	RD¼PM 223J
R118	Carbon film 22k	RD¼PM 223J
R119	Carbon film 47k	RD¼PM 473J
R120	Carbon film 47k	RD¼PM 473J
R121	Carbon film 18k	RD¼PM 183J
R122	Carbon film 18k	RD¼PM 183J
R123	Carbon film 6.8k	RD¼PM 682J
R124	Carbon film 6.8k	RD¼PM 682J
R127	Wire wound 150 5W	RT5B 151K
R128	Wire wound 150 5W	RT5B 151K
R129	Carbon film 2.2M	RD¼PM 225J
R130	Carbon film 2.2M	RD¼PM 225J
R131	Carbon film 2.2M	RD¼PM 225J
R132	Carbon film 2.2M	RD¼PM 225J
R133	Carbon film 2.2M	RD¼PM 225J
R134	Carbon film 2.2M	RD¼PM 225J
R135	Carbon film 2.2M	RD¼PM 225J
R136	Carbon film 2.2M	RD¼PM 225J
R139	Metal oxide 910 2W	RS2P 911J
R140	Carbon film 10k	RD¼PM 103J
R141	Carbon film 10k	RD¼PM 103J

SWITCHES

Symbol	Description	Part No.
S1	Selector switch (FUNCTION)	ASB-025-A
S2	Slide switch (PHONO 2 IMP)	ASH-007-0
S3	Selector switch (MODE)	ASB-022-A
S4	LEVEL SET switch with VOLUME	ASB-024-B
S5	Selector switch (BASS-100Hz)	ASC-043-A
S6	Selector switch (TREBLE-10kHz)	ASC-042-A
S7	Selector switch (BASS-50Hz)	ASC-045-A
S8	Selector switch (TREBLE-20kHz)	ASC-044-A
S9	Slide switch (PRE/POWER)	ASH-006-0
S10	Selector switch (SPEAKERS)	ASB-026-A
S11	Lever switch (POWER) for KUW model	ASK-039-0
	Lever switch (POWER) for FWV model	ASK-040-0
S12	Relay	ASR-003-0

OTHERS

Symbol	Description	Part No.
	Equalizer amp ass'y	AWF-007-0
	Control amp ass'y	AWG-018-A
	Power amp ass'y	AWH-023-B
	Switch-A ass'y	AWS-038-0
	Switch-B ass'y	AWS-039-0
	Switch-C ass'y	AWS-040-0
	Filter amp ass'y	AWK-021-0

Symbol	Description	Part No.	
	Power supply circuit-A ass'y	AWR-031-0	
	Power supply circuit-B ass'y	AWR-032-0	
	Protection circuit ass'y	AWM-025-A	
	Volume ass'y	AWX-048-0	
	Front panel ass'y	ANB-180-A	
	Wooden case	AMM-022-A	
	Foot	AEC-083-A	
	Knob for VOLUME	AAB-045-0	
	Knob for LEVEL SET	AAB-044-0	
	Knob for FUNCTION	AAB-040-0	
	Knob for BALANCE, MODE	AAB-041-0	
	Knob for SPEAKERS, BASS (100Hz) and TREBLE (10kHz)	AAB-042-0	
	Knob for BASS(50Hz), TREBLE (20kHz)	AAB-043-0	
	Knob for LEVEL CONTROL	AAB-046-A	
	Knob for lever switch	AAD-040-B	
	Four-fold phono jack-A	AKB-014-0	
	Four-fold phono jack-B	AKB-015-0	
	Six-fold phono jack-B	AKB-017-0	
	Screw for grounding	AKE-012-A	
	Power transformer for KUW model	ATT-107-0	
	Power transformer for FVW model	ATT-108-0	
	Pilot lamp for indicator	AEL-007-0	
	Pilot lamp for protection	AEL-014-0	
	Fuse 1A (protection) for KUW model	E21-033-0	
	Fuse 1A (protection) for FVW model	E21-034-A	
	Fuse 1A (protection) for KUW model	AEK-004-0	
	Fuse 1A (protection) for FVW model	AEK-022-0	
	Fuse 4A (AC power) for KUW model	AEK-025-0	
	Fuse 2.5A (AC power) for FVW model	AEK-020-0	
	Speaker terminal board (triple type)	AKE-013-0	
	Spare AC outlet for KUW model	AKP-005-0	
	Spare AC outlet for FVW model	AKP-002-0	
	Fuse holder for KUW model	AKR-008-0	
	Fuse holder for FVW model	AKR-001-0	
	Microphone jack	K72-024-0	
	Headphone jack	K72-026-0	
	5P connector (DIN type)	K93-003-B	
	AC power cord for KUW model	ADG-003-0	
	AC power cord for FVW model	ADG-004-0	
	Screw to fix wooden case	ABA-010-A	
	Operating instructions	ARB-070-0	
	Connection cord with pin-plug	ADE-005-0	
	Packing case for KUW model	AHD-139-A	
	Packing case for FVW model	AHD-138-0	
	Styrotector	HII-070-0	

11.2 EQUALIZER AMP ASS'Y(AWF-007-0)

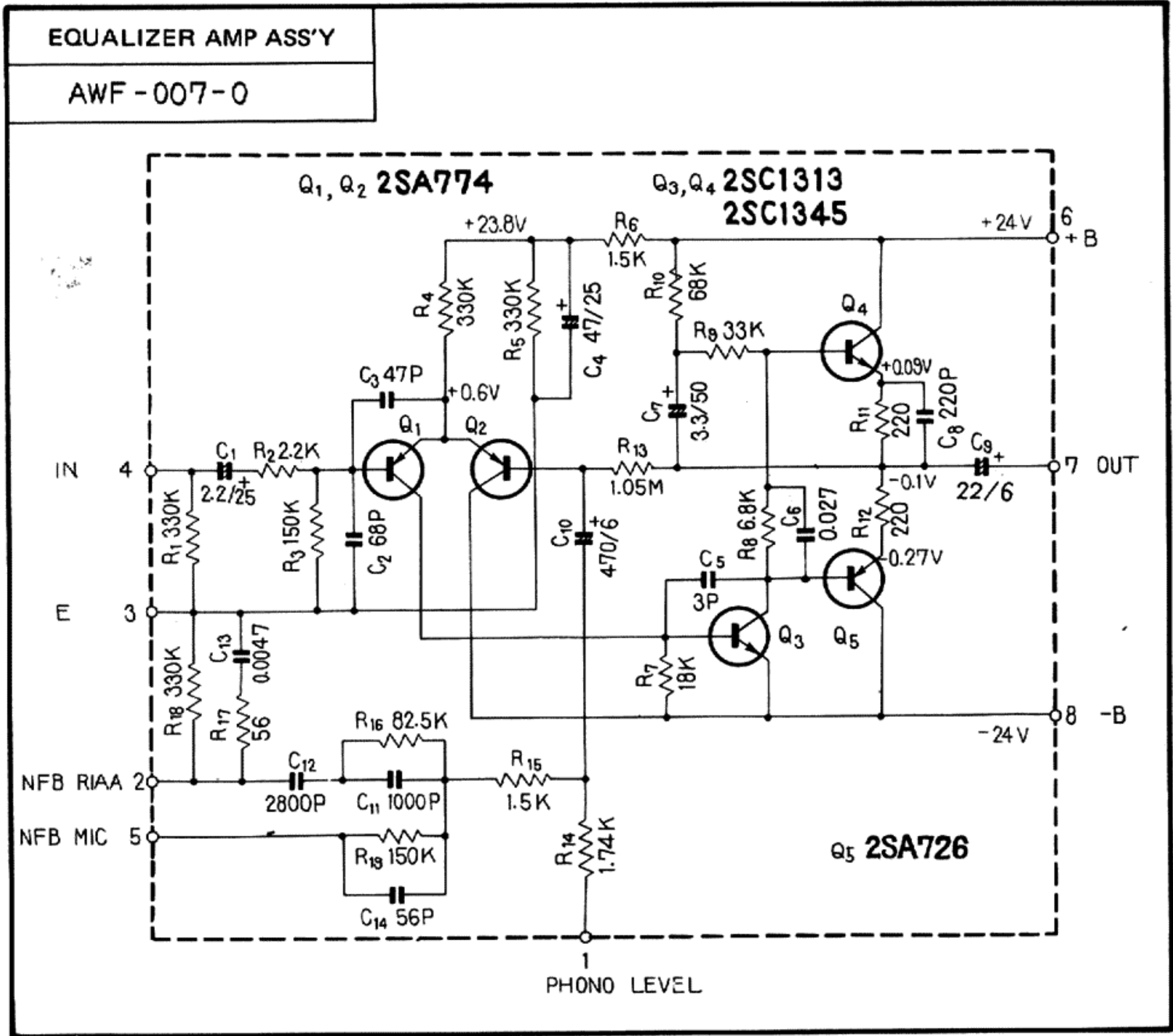

Foil Side

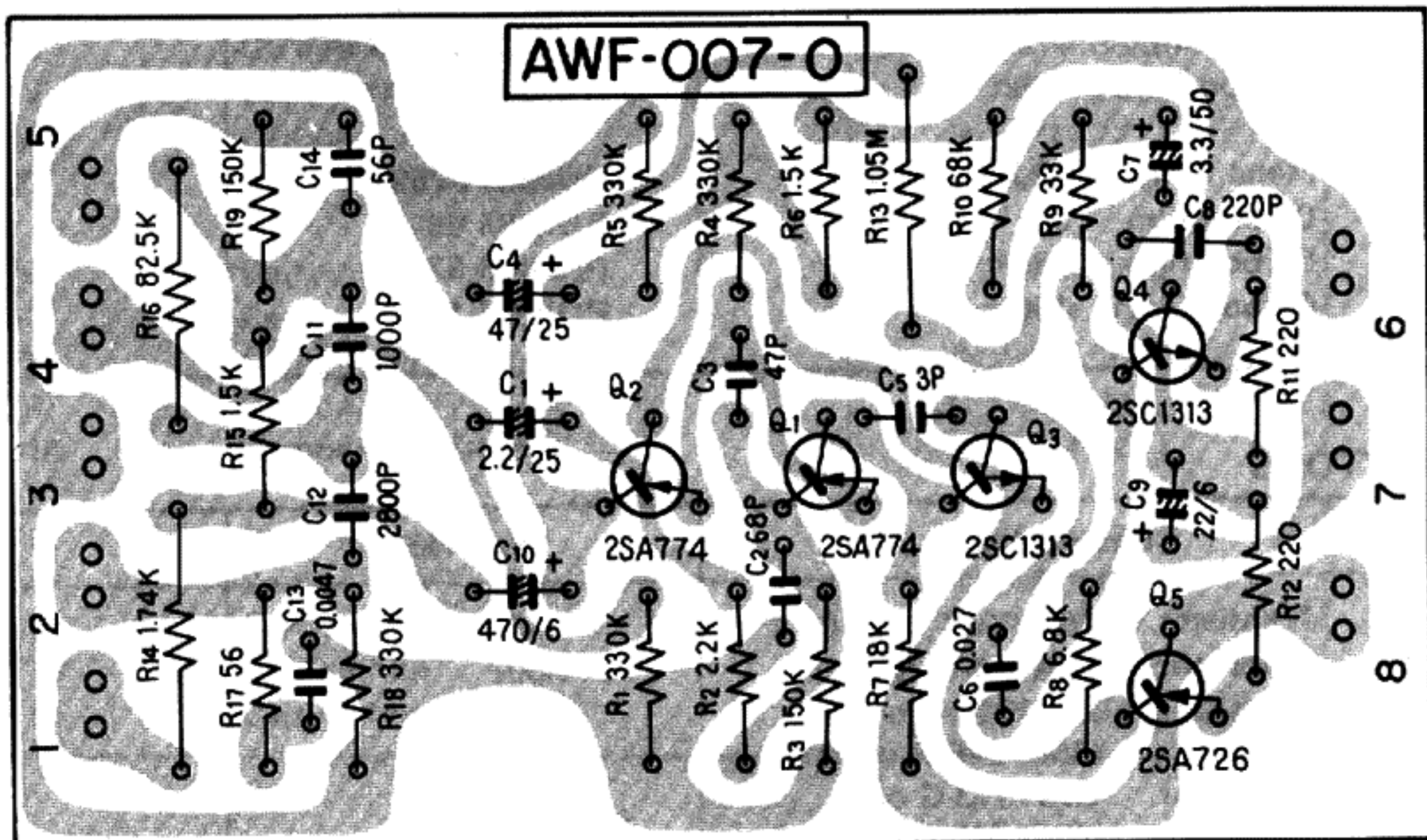

Parts List of Equalizer Amp Ass'y (AWF-007-0)

CAPACITORS

Symbol	Description	Part No.
C1	Electrolytic 2.2 25V	CSSA 2R2M 25
C2	Ceramic 68p 50V	CCDSL 680K 50
C3	Ceramic 47p 50V	CCDSL 470K 50
C4	Electrolytic 47 25V	CEA 470P 25
C5	Ceramic 3p 50V	CCDSL 030C 50
C6	Mylar 0.027 50V	CQMA 273K 50
C7	Electrolytic 3.3 50V	CEA 3R3P 50
C8	Ceramic 220p 50V	CCDSL 221K 50
C9	Electrolytic 22 6V	CSSA 220M 6
C10	Electrolytic 470 6V	CEA 471P 6
C11	Styrol 0.001 50V	CQSA 102G 50
C12	Styrol 0.0028 50V	CQSA 282G 50
C13	Mylar 0.0047 50V	CQMA 472K 50
C14	Ceramic 56p 50V	CCDSL 560K 50

RESISTORS

Symbol	Description	Part No.
R1	Carbon film 330k	RD¼PM 334J
R2	Carbon film 2.2k	RD¼PM 222J
R3	Carbon film 150k	RD¼PM 154J
R4	Carbon film 330k	RD¼PM 334J
R5	Carbon film 330k	RD¼PM 334J
R6	Carbon film 1.5k	RD¼PM 152J
R7	Carbon film 18k	RD¼PM 183J
R8	Carbon film 6.8k	RD¼PM 682J
R9	Carbon film 33k	RD¼PM 333J
R10	Carbon film 68k	RD¼PM 683J
R11	Carbon film 220	RD¼PM 221J
R12	Carbon film 220	RD¼PM 221J
R13	Metal film 1.05M ½W	RN½SS 1054F
R14	Metal film 1.74k ½W	RN½SR 1741F
R15	Carbon film 1.5k	RD¼PM 152J
R16	Metal film 82.5k ½W	RN½SR 8252F
R17	Carbon film 56	RD¼PM 560J
R18	Carbon film 330k	RD¼PM 334J
R19	Carbon film 150k	RD¼PM 154J

SEMICONDUCTORS

Symbol	Description	Part No.
Q1	Transistor 2SA774-T, S or U	
Q2	Transistor 2SA774-T, S or U	
Q3	Transistor 2SC1313-G or F (2SC1345-D or E)	
Q4	Transistor 2SC1313-G or F (2SC1345-D or E)	
Q5	Transistor 2SA726-G or F	

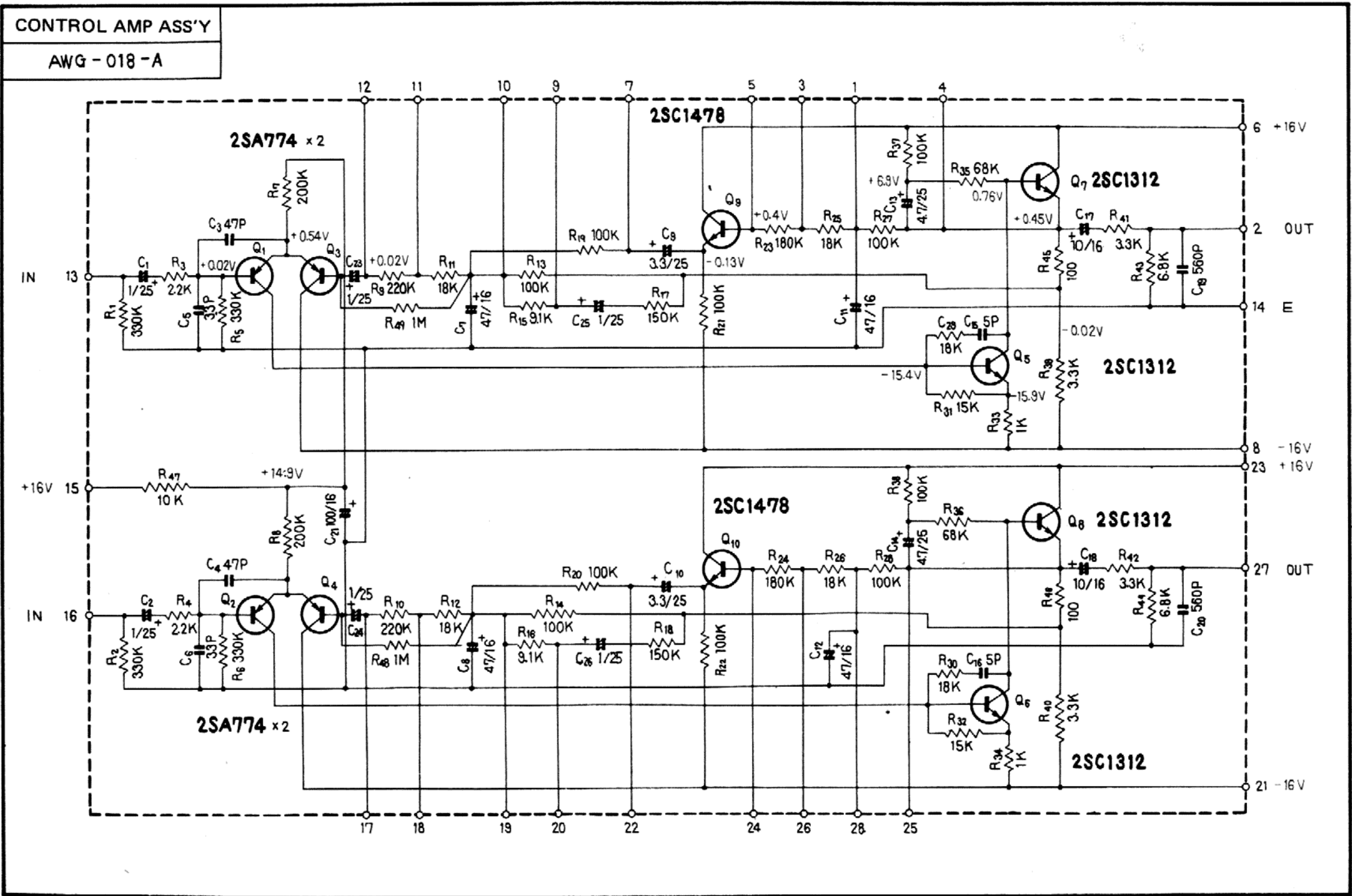

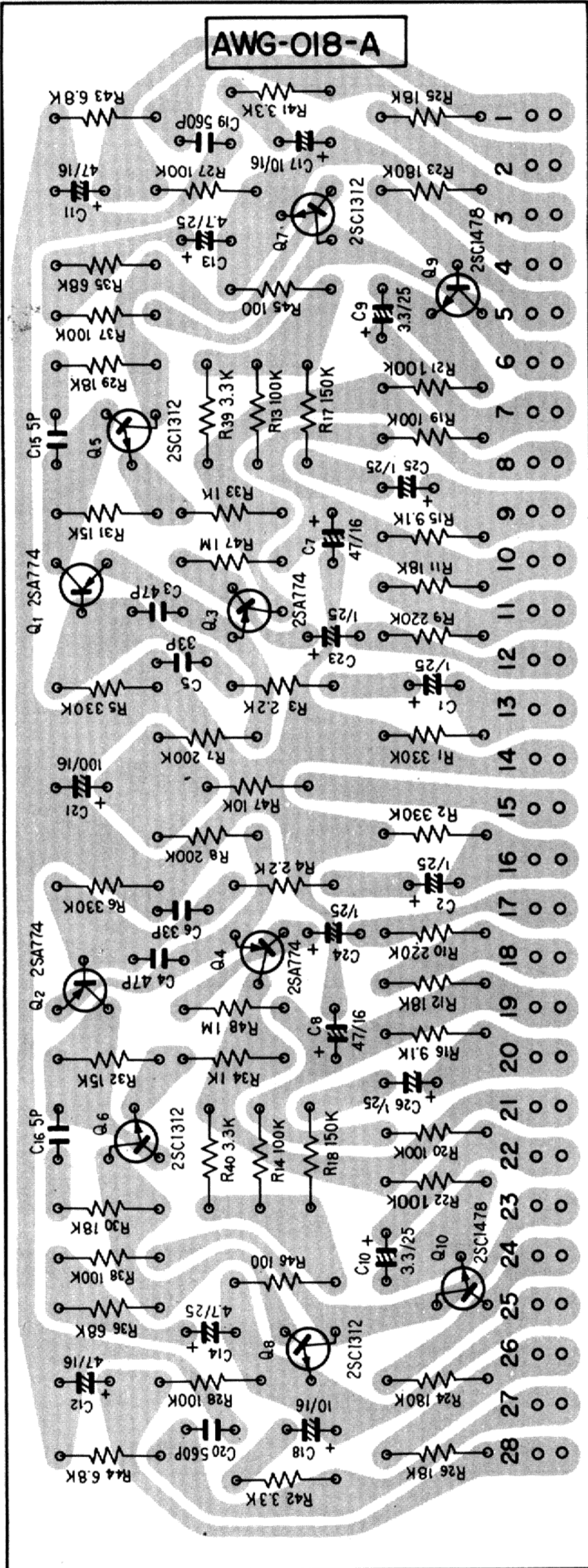

Foil Side

Parts List of Control Amp Ass'y (AWG-018-A)

CAPACITORS

Symbol	Description	Part No.
C1	Electrolytic 1 25V	CSSA 010M 25
C2	Electrolytic 1 25V	CSSA 010M 25
C3	Ceramic 47p 50V	CCDSL 470K 50
C4	Ceramic 47p 50V	CCDSL 470K 50
C5	Ceramic 33p 50V	CCDSL 330K 50
C6	Ceramic 33p 50V	CCDSL 330K 50
C7	Electrolytic 47 16V	CEA 470P 16
C8	Electrolytic 47 16V	CEA 470P 16
C9	Electrolytic 3.3 25V	CSSA 3R3M 25
C10	Electrolytic 3.3 25V	CSSA 3R3M 25
C11	Electrolytic 47 16V	CEA 470P 16
C12	Electrolytic 47 16V	CEA 470P 16
C13	Electrolytic 4.7 25V	CEA 4R7P 25
C14	Electrolytic 4.7 25V	CEA 4R7P 25
C15	Ceramic 5p 50V	CCDSL 050D 50
C16	Ceramic 5p 50V	CCDSL 050D 50
C17	Electrolytic 10 25V	CSZA 100M 25
C18	Electrolytic 10 25V	CSZA 100M 25
C19	Styrol 560p 50V	CQSA 561K 50
C20	Styrol 560p 50V	CQSA 561K 50
C21	Electrolytic 100 16V	CEA 101P 16
C22	Electrolytic 1 25V	CSSA 010M 25
C23	Electrolytic 1 25V	CSSA 010M 25
C24	Electrolytic 1 25V	CSSA 010M 25
C25	Electrolytic 1 25V	CSSA 010M 25
C26	Electrolytic 1 25V	CSSA 010M 25

RESISTORS

Symbol	Description	Part No.
R1	Carbon film 330k	RD¼PM 334J
R2	Carbon film 330k	RD¼PM 334J
R3	Carbon film 2.2k	RD¼PM 222J
R4	Carbon film 2.2k	RD¼PM 222J
R5	Carbon film 330k	RD¼PM 334J
R6	Carbon film 330k	RD¼PM 334J
R7	Carbon film 200k	RD¼PM 204J
R8	Carbon film 200k	RD¼PM 204J
R9	Carbon film 220k	RD¼PM 224J
R10	Carbon film 220k	RD¼PM 224J
R11	Carbon film 18k	RD¼PM 183J
R12	Carbon film 18k	RD¼PM 183J
R13	Carbon film 100k	RD¼PM 104J
R14	Carbon film 100k	RD¼PM 104J
R15	Carbon film 9.1k	RD¼PM 912J

Symbol	Description	Part No.
R16	Carbon film 9.1k	RD¼PM 912J
R17	Carbon film 150k	RD¼PM 154J
R18	Carbon film 150k	RD¼PM 154J
R19	Carbon film 100k	RD¼PM 104J
R20	Carbon film 100k	RD¼PM 104J
R21	Carbon film 100k	RD¼PM 104J
R22	Carbon film 100k	RD¼PM 104J
R23	Carbon film 180k	RD¼PM 184J
R24	Carbon film 180k	RD¼PM 184J
R25	Carbon film 18k	RD¼PM 183J
R26	Carbon film 18k	RD¼PM 183J
R27	Carbon film 100k	RD¼PM 104J
R28	Carbon film 100k	RD¼PM 104J
R29	Carbon film 18k	RD¼PM 183J
R30	Carbon film 18k	RD¼PM 183J
R31	Carbon film 15k	RD¼PM 153J
R32	Carbon film 15k	RD¼PM 153J
R33	Carbon film 1k	RD¼PM 102J
R34	Carbon film 1k	RD¼PM 102J
R35	Carbon film 68k	RD¼PM 683J
R36	Carbon film 68k	RD¼PM 683J
R37	Carbon film 100k	RD¼PM 104J
R38	Carbon film 100k	RD¼PM 104J
R39	Carbon film 3.3k	RD¼PM 332J
R40	Carbon film 3.3k	RD¼PM 332J
R41	Carbon film 3.3k	RD¼PM 332J
R42	Carbon film 3.3k	RD¼PM 332J
R43	Carbon film 6.8k	RD¼PM 682J
R44	Carbon film 6.8k	RD¼PM 682J
R45	Carbon film 100	RD¼PM 101J
R46	Carbon film 100	RD¼PM 101J
R47	Carbon film 10k	RD¼PM 103J
R48	Carbon film 1M	RD¼PM 105J
R49	Carbon film 1M	RD¼PM 105J

SEMICONDUCTORS

Symbol	Description	Part No.
Q1	Transistor 2SA774-T or U	
Q2	Transistor 2SA774-T or U	
Q3	Transistor 2SA774-T or U	
Q4	Transistor 2SA774-T or U	
Q5	Transistor 2SC1312-F or G (2SC1344-D or E)	
Q6	Transistor 2SC1312-F or G (2SC1344-D or E)	
Q7	Transistor 2SC1312-F or G (2SC1344-D or E)	
Q8	Transistor 2SC1312-F or G (2SC1344-D or E)	
Q9	Transistor 2SC1478-T or U	
Q10	Transistor 2SC1478-T or U	

11.4 FILTER AMP ASS'Y (AWK-021-0)

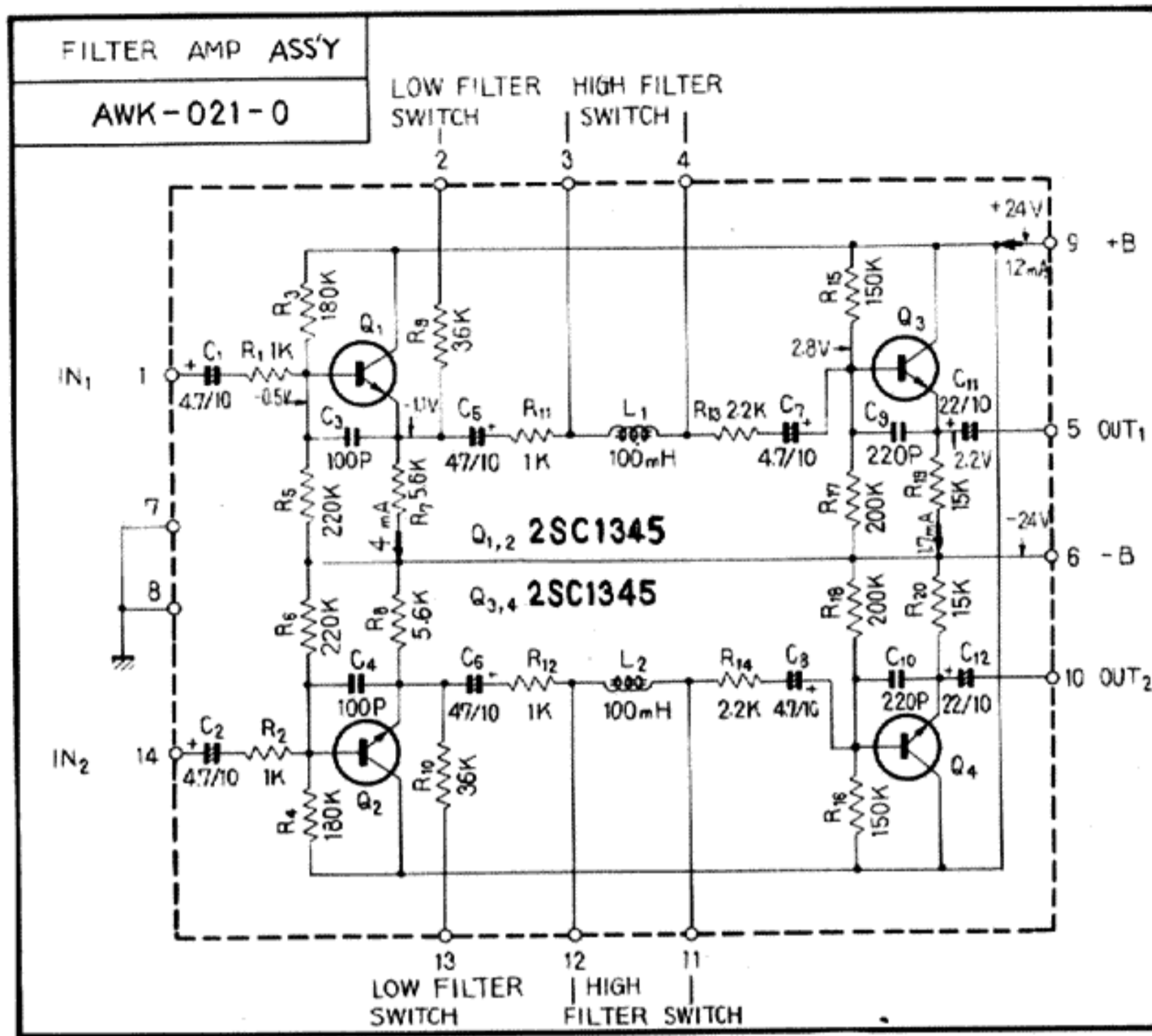

Foil Side

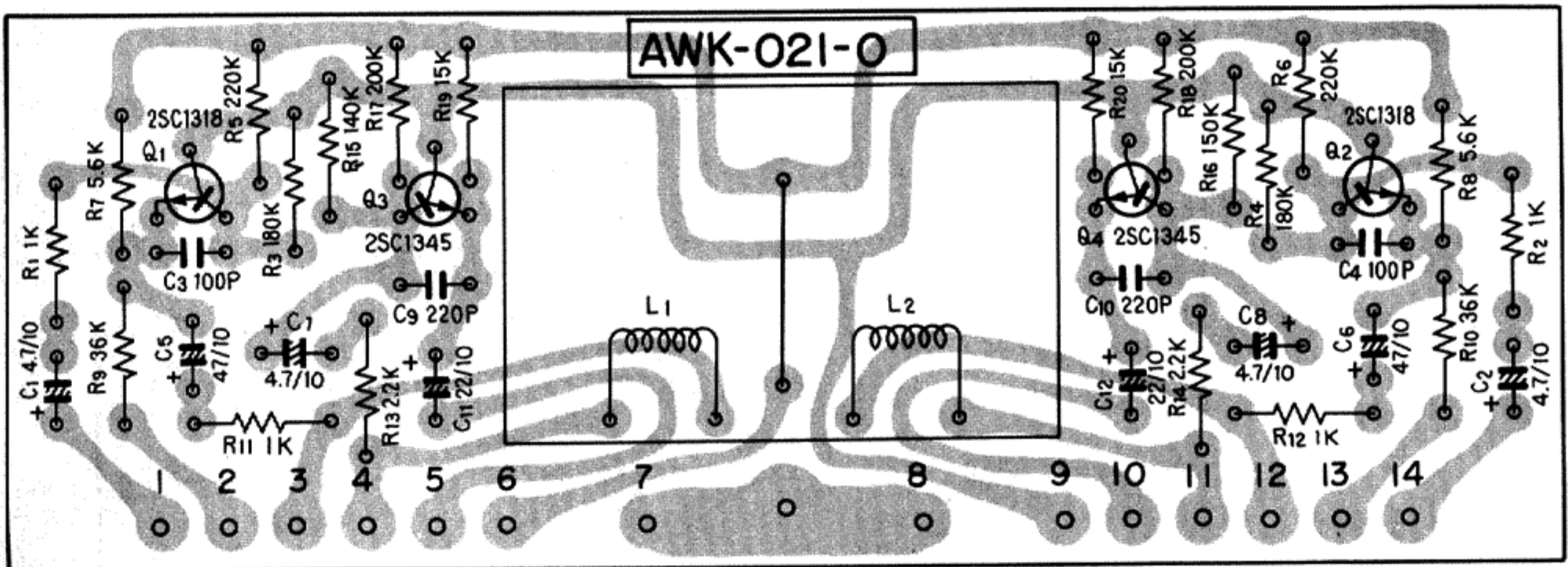

Parts List of Filter Amp Ass'y (AWK-021-0)

CAPACITORS

Symbol	Description	Part No.
C1	Electrolytic 4.7 10V	CSSA 4R7X 10
C2	Electrolytic 4.7 10V	CSSA 4R7X 10
C3	Ceramic 100p 50V	CCDSL 101K 50
C4	Ceramic 100p 50V	CCDSL 101K 50
C5	Electrolytic 47 10V	CEA 470P 10
C6	Electrolytic 47 10V	CEA 470P 10
C7	Electrolytic 4.7 10V	CSSA 4R7X 10
C8	Electrolytic 4.7 10V	CSSA 4R7X 10
C9	Ceramic 220p 50V	CCDSL 221K 50
C10	Ceramic 220p 50V	CCDSL 221K 50
C11	Electrolytic 22 10V	CEA 220P 10
C12	Electrolytic 22 10V	CEA 220P 10

RESISTORS

Symbol	Description	Part No.
R1	Carbon film 1k	RD¼PM 102J
R2	Carbon film 1k	RD¼PM 102J
R3	Carbon film 180k	RD¼PM 184J
R4	Carbon film 180k	RD¼PM 184J
R5	Carbon film 220k	RD¼PM 224J
R6	Carbon film 220k	RD¼PM 224J
R7	Carbon film 5.6k	RD¼PM 562J
R8	Carbon film 5.6k	RD¼PM 562J
R9	Carbon film 36k	RD¼PM 363J
R10	Carbon film 36k	RD¼PM 363J
R11	Carbon film 1k	RD¼PM 102J
R12	Carbon film 1k	RD¼PM 102J
R13	Carbon film 2.2k	RD¼PM 222J
R14	Carbon film 2.2k	RD¼PM 222J
R15	Carbon film 150k	RD¼PM 154J
R16	Carbon film 150k	RD¼PM 154J
R17	Carbon film 200k	RD¼PM 204J
R18	Carbon film 200k	RD¼PM 204J
R19	Carbon film 15k	RD¼PM 153J
R20	Carbon film 15k	RD¼PM 153J

SEMICONDUCTORS

Symbol	Description	Part No.
Q1	Transistor 2SC1345-D or E (2SC1313-G or F)	
Q2	Transistor 2SC1345-D or E (2SC1313-G or F)	
Q3	Transistor 2SC1345-D or E (2SC1313-G or F)	
Q4	Transistor 2SC1345-D or E (2SC1313-G or F)	

COILS

Symbol	Description	Part No.
L1	Choke coil 104k	ATM-012-0
L2	Choke coil 104k	ATM-012-0

POWER AMP ASS'Y

AWH-023-B

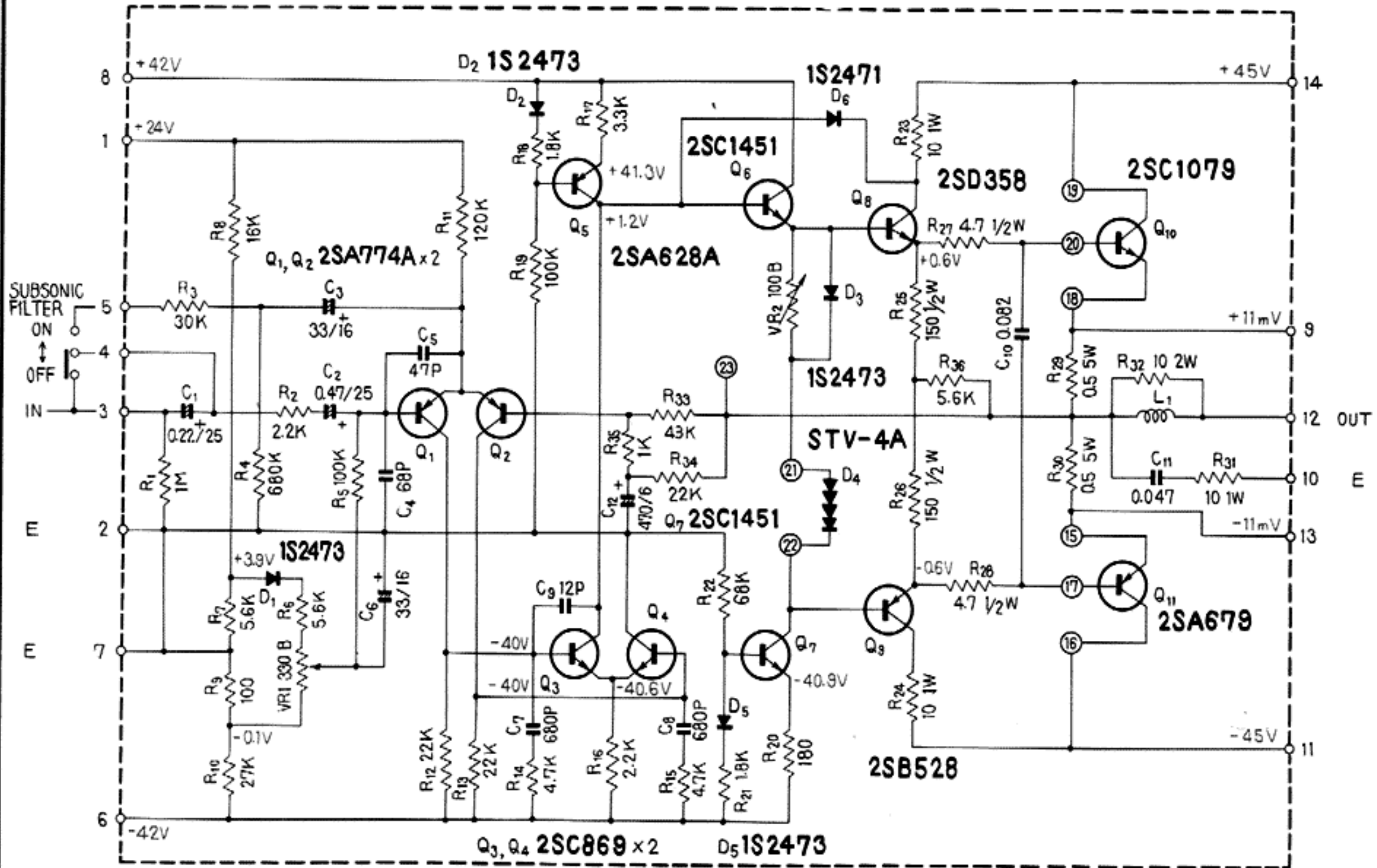

11.5 POWER AMP ASS'Y (AWH-023-B)

Foil side

AWH-023-B

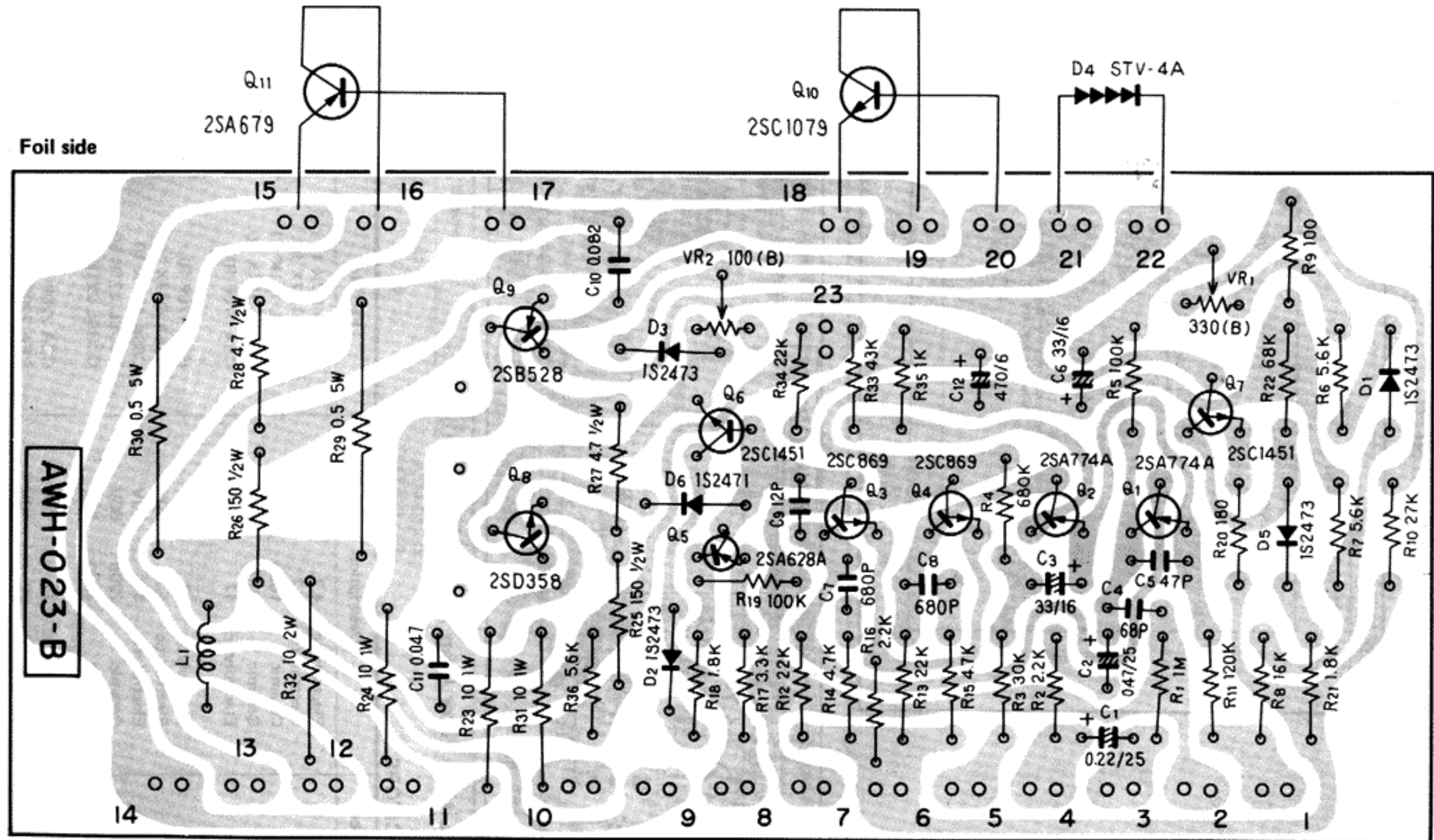

Parts List of Power Amp Ass'y(AWH-023-B)

CAPACITORS

Symbol	Description	Part No.
C1	Electrolytic 0.22 25V	CSSA R22M 25-85C
C2	Electrolytic 0.47 25V	CSSA R47M 25-85C
C3	Electrolytic 33 16V	CEA 330P 16-85C
C4	Ceramic 68p 50V	CCDSL 680K 50
C5	Ceramic 47p 50V	CCDSL 470K 50
C6	Electrolytic 33 16V	CEA 330P 16-85C
C7	Ceramic 680p 50V	CKDYB 681K 50
C8	Ceramic 680p 50V	CKDYB 681K 50
C9	Ceramic 12p 50V	CCDSL 120K 50
C10	Mylar 0.082 50V	CQMA 823K 50
C11	Mylar 0.047 50V	CQMA 473K 50
C12	Electrolytic 470 6V	CEA 471P 6-85C

RESISTORS

Symbol	Description	Part No.
R1	Carbon film 1M	RD¼PM 105J
R2	Carbon film 2.2k	RD¼PM 222J
R3	Carbon film 30k	RD¼PM 303J
R4	Carbon film 680k	RD¼PM 684J
R5	Carbon film 100k	RD¼PM 104J
R6	Carbon film 5.6k	RD¼PM 562J
R7	Carbon film 5.6k	RD¼PM 562J
R8	Carbon film 16k	RD¼PM 163J
R9	Carbon film 100	RD¼PM 101J
R10	Carbon film 27k	RD¼PM 273J
R11	Carbon film 120k	RD¼PM 124J
R12	Carbon film 22k	RD¼PM 223J
R13	Carbon film 22k	RD¼PM 223J
R14	Carbon film 4.7k	RD¼PM 472J
R15	Carbon film 4.7k	RD¼PM 472J
R16	Carbon film 2.2k	RD¼PM 222J
R17	Carbon film 3.3k	RD¼PM 332J
R18	Carbon film 1.8k	RD¼PM 182J
R19	Carbon film 100k	RD¼PM 104J
R20	Carbon film 180	RD¼PM 181J
R21	Carbon film 1.8k	RD¼PM 182J
R22	Carbon film 68k	RD¼PM 683J
R23	Metal oxide 10 1W	RS1P 100J
R24	Metal oxide 10 1W	RS1P 100J
R25	Carbon film 150 ½W	RD½PS 151J
R26	Carbon film 150 ½W	RD½PS 151J
R27	Carbon film 4.7 ½W	RD½PS 4R7J
R28	Carbon film 4.7 ½W	RD½PS 4R7J
R29	Wire wound 0.5 5W	RT5B 0R5K
R30	Wire wound 0.5 5W	RT5B 0R5K

Symbol	Description	Part No.
R31	Metal oxide 10 1W	RS1P 100J
R32	Metal oxide 10 2W	RS2P 100J
R33	Carbon film 43k	RD¼PM 433J
R34	Carbon film 22k	RD¼PM 223J
R35	Carbon film 1k	RD¼PM 102J
R36	Carbon film 5.6k	RD¼PM 562J

SEMICONDUCTORS

Symbol	Description	Part No.
Q1	Transistor 2SA774A-T, U or S	
Q2	Transistor 2SA774A-T, U or S	
Q3	Transistor 2SC869-D or C	
Q4	Transistor 2SC869-D or C	
Q5	Transistor 2SA628A-D or C	
Q6	Transistor 2SC1451-V or B	
Q7	Transistor 2SC1451-V or B	
Q8	Transistor 2SD358-D or C	
Q9	Transistor 2SB528-D or C	
Q10	Transistor 2SC1079-R or Y	
Q11	Transistor 2SA679-R or Y	
D1	Diode 1S2473	
D2	Diode 1S2473	
D3	Diode 1S2473	
D4	Varistor STV-4A	
D5	Diode 1S2473	
D6	Diode 1S2471	

COIL

Symbol	Description	Part No.
L1	AF choke coil	T63-009-0

POTENTIOMETERS

Symbol	Description	Part No.
VR1	Semi-fixed(330-B)	ACP-020-0
VR2	Semi-fixed(100-B)	ACP-019-0

OTHERS

Symbol	Description	Part No.
	Socket for power transistor	AKH-001-0
	Spacer (Mica)	AEC-076-0
	Heat Sink (2SD358)	ANH-135-A
	(2SB528)	
	Holder for Valistor	ANG-073-0

11.6 PROTECTION CIRCUIT ASS'Y (AWM-025-A)

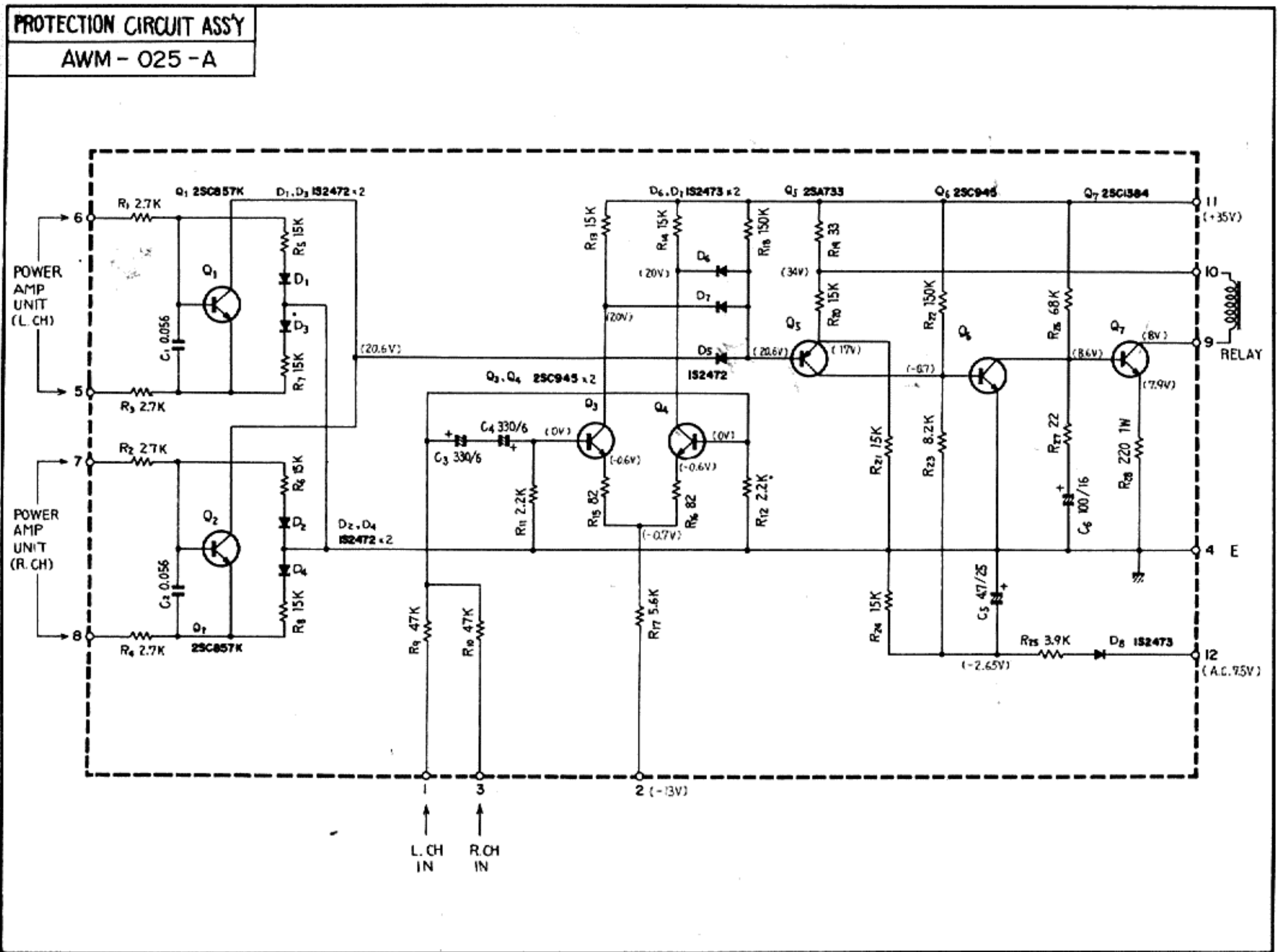

Foil Side

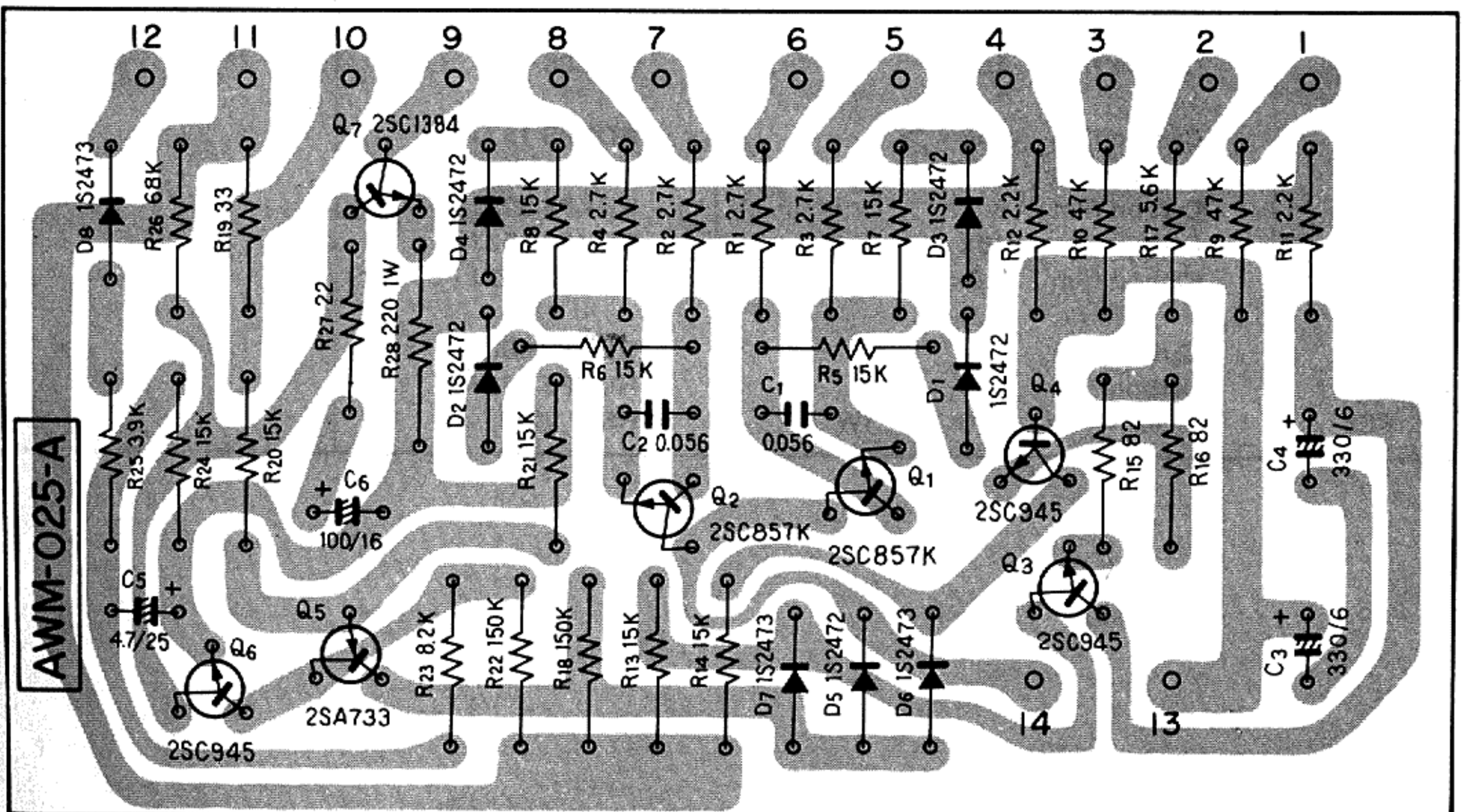

Parts List of Protection Circuit Ass'y (AWM-025-A)

CAPACITORS

Symbol	Description	Part No.
C1	Mylar 0.056 50V	CQMA 563K 50
C2	Mylar 0.056 50V	CQMA 563K 50
C3	Electrolytic 330 6V	CEA 331P 6
C4	Electrolytic 330 6V	CEA 331P 6
C5	Electrolytic 4.7 25V	CEA 4R7P 25
C6	Electrolytic 100 16V	CEA 101P 16

RESISTORS

Symbol	Description	Part No.
R1	Carbon film 2.7k	RD¼PS 272J
R2	Carbon film 2.7k	RD¼PS 272J
R3	Carbon film 2.7k	RD¼PS 272J
R4	Carbon film 2.7k	RD¼PS 272J
R5	Carbon film 15k	RD¼PS 153J
R6	Carbon film 15k	RD¼PS 153J
R7	Carbon film 15k	RD¼PS 153J
R8	Carbon film 15k	RD¼PS 153J
R9	Carbon film 47k	RD¼PS 473J
R10	Carbon film 47k	RD¼PS 473J
R11	Carbon film 2.2k	RD¼PS 222J
R12	Carbon film 2.2k	RD¼PS 222J
R13	Carbon film 15k	RD¼PS 153J
R14	Carbon film 15k	RD¼PS 153J
R15	Carbon film 82	RD¼PS 820J
R16	Carbon film 82	RD¼PS 820J
R17	Carbon film 5.6k	RD¼PS 562J
R18	Carbon film 150k	RD¼PS 154J
R19	Carbon film 33	RD¼PS 330J
R20	Carbon film 15k	RD¼PS 153J
R21	Carbon film 15k	RD¼PS 153J
R22	Carbon film 150k	RD¼PS 154J
R23	Carbon film 8.2k	RD¼PS 822J
R24	Carbon film 15k	RD¼PS 153J
R25	Carbon film 3.9k	RD¼PS 392J
R26	Carbon film 68k	RD¼PS 683J
R27	Carbon film 22	RD¼PS 220J
R28	Metal oxide 220 1W	RS1P 221J

SEMICONDUCTORS

Symbol	Description	Part No.	
Q1	Transistor 2SC857K-A		
Q2	Transistor 2SC857K-A		
Q3	Transistor 2SC945-Q or R		
Q4	Transistor 2SC945-Q or R		
Q5	Transistor 2SA733-Q or R		
Q6	Transistor 2SC945-Q or R		
Q7	Transistor 2SC1384-R or Q		
D1	Diode 1S2472		
D2	Diode 1S2472		
D3	Diode 1S2472		
D4	Diode 1S2472		
D5	Diode 1S2472		
D6	Diode 1S2473		
D7	Diode 1S2473		
D8	Diode 1S2473		

11.7 POWER SUPPLY CIRCUIT-A ASS'Y (AWR-031-0)

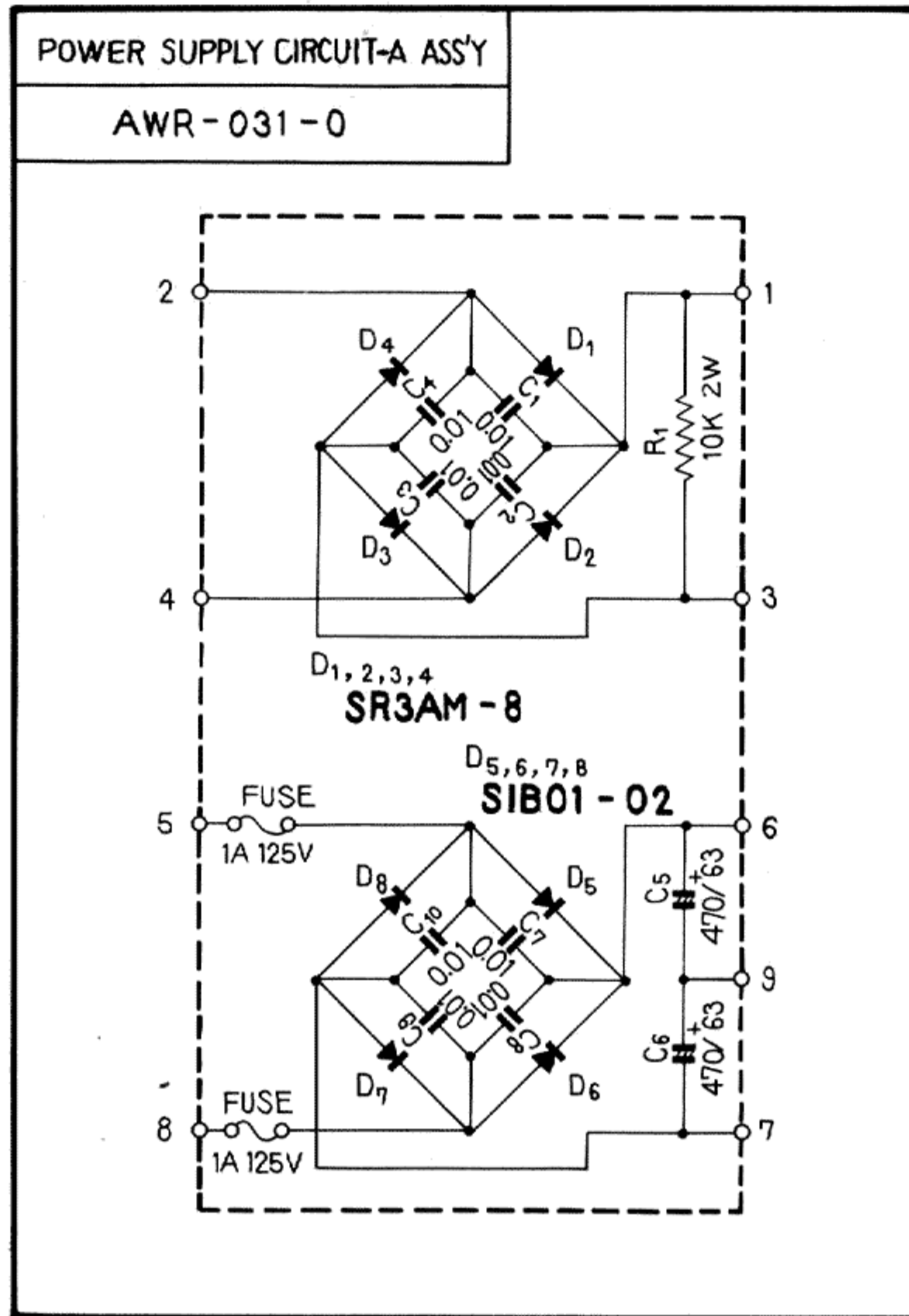

Foil Side

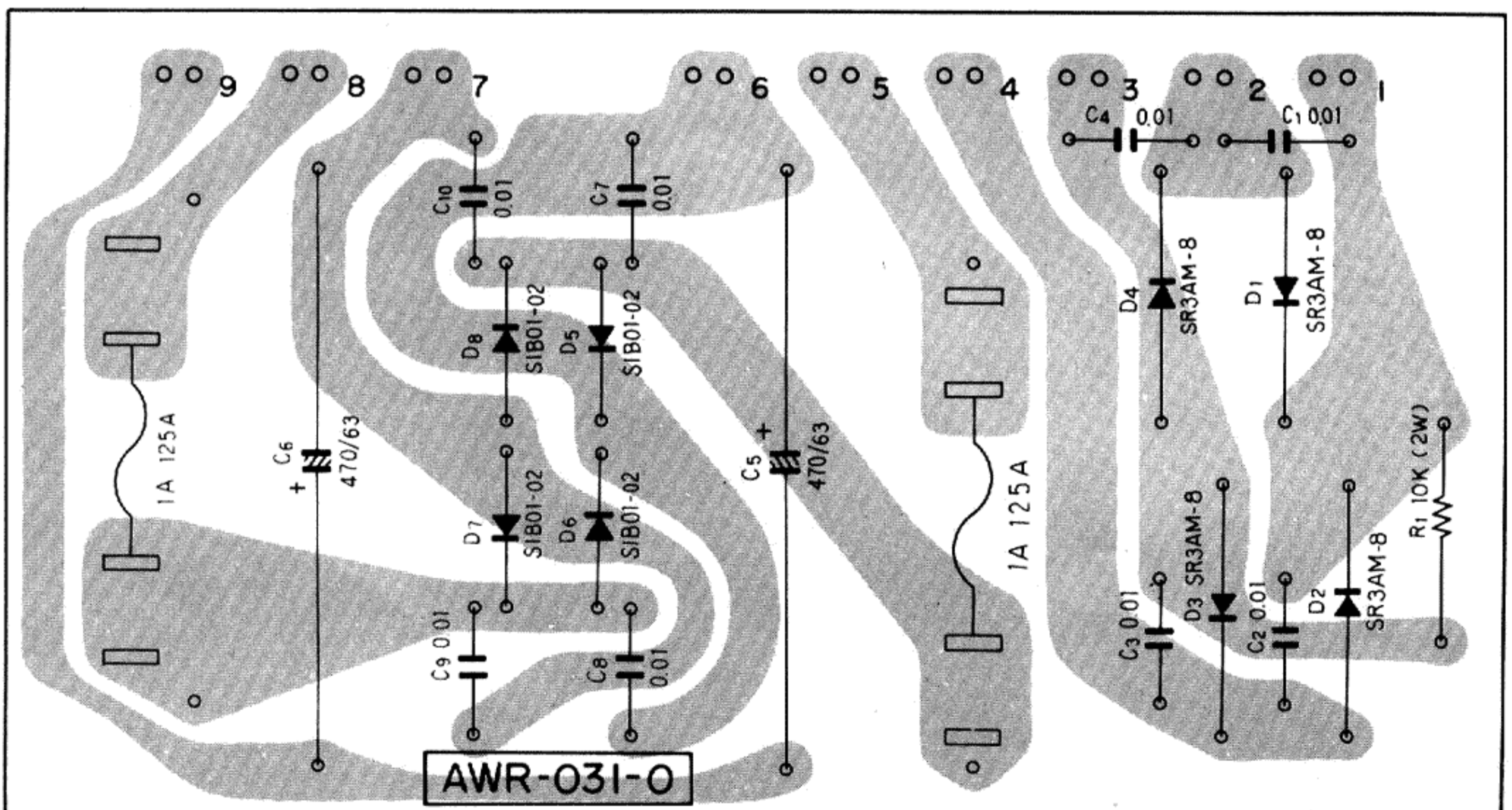

Parts List of Power Supply Circuit-A Ass'y(AWR-031-0)

CAPACITORS

Symbol	Description	Part No.
C1	Ceramic 0.01 150V	ACG-004-0
C2	Ceramic 0.01 150V	ACG-004-0
C3	Ceramic 0.01 150V	ACG-004-0
C4	Ceramic 0.01 150V	ACG-004-0
C5	Electrolytic 470 63V	CEB 471P 63-85C
C6	Electrolytic 470 63V	CEB 471P 63-85C
C7	Ceramic 0.01 150V	ACG-004-0
C8	Ceramic 0.01 150V	ACG-004-0
C9	Ceramic 0.01 150V	ACG-004-0
C10	Ceramic 0.01 150V	ACG-004-0

RESISTOR

Symbol	Description	Part No.
R1	Metal oxide 10k 2W	RS2P 103K

SEMICONDUCTORS

Symbol	Description	Part No.
D1	Diode SR3AM-8	
D2	Diode SR3AM-8	
D3	Diode SR3AM-8	
D4	Diode SR3AM-8	
D5	Diode SIB01-02	
D6	Diode SIB01-02	
D7	Diode SIB01-02	
D8	Diode SIB01-02	

OTHER

Symbol	Description	Part No.
	Fuse holder	K91-006-0

11.8 POWER SUPPLY CIRCUIT-B ASS'Y (AWR-032-0)

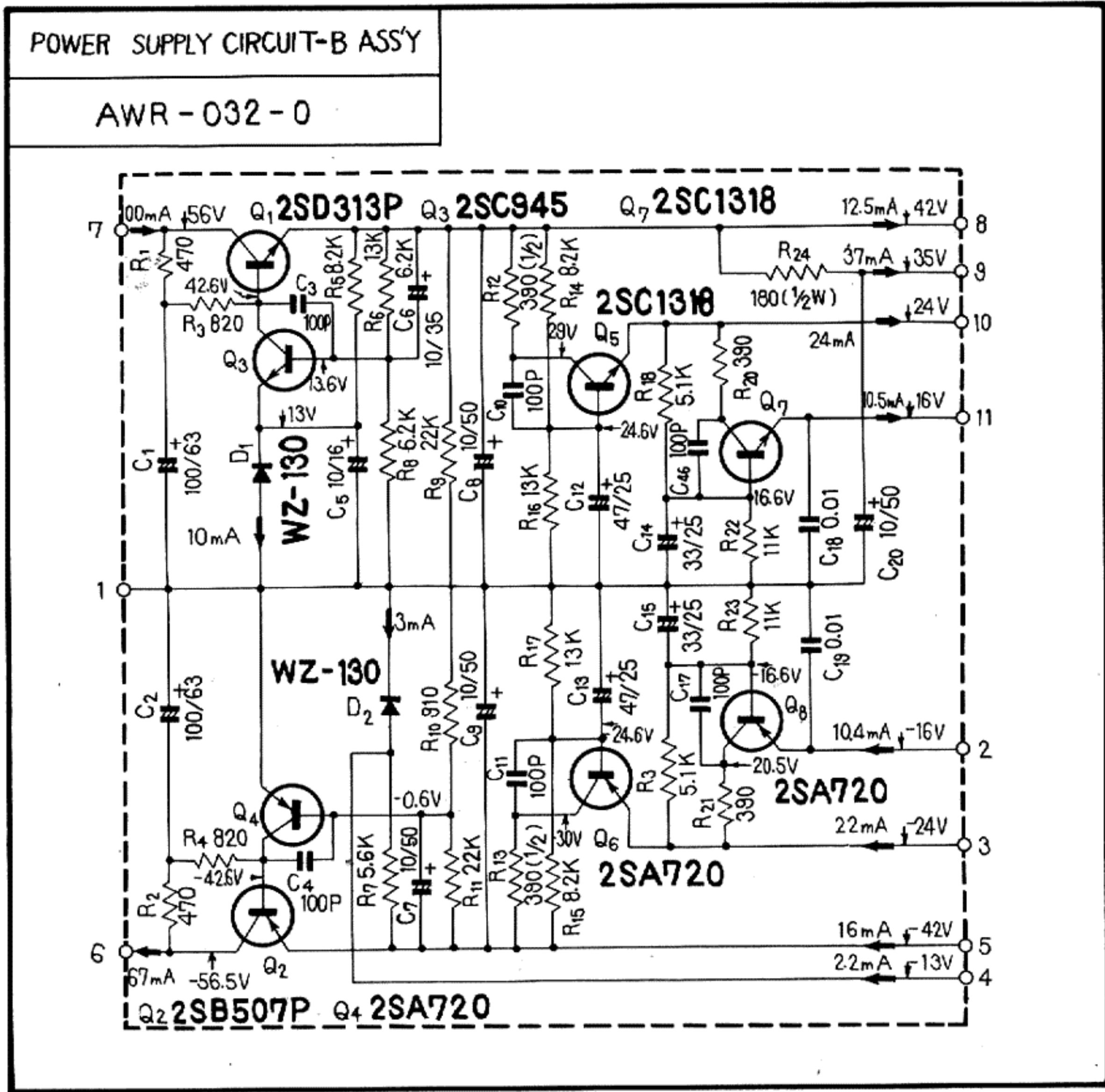

Foil Side

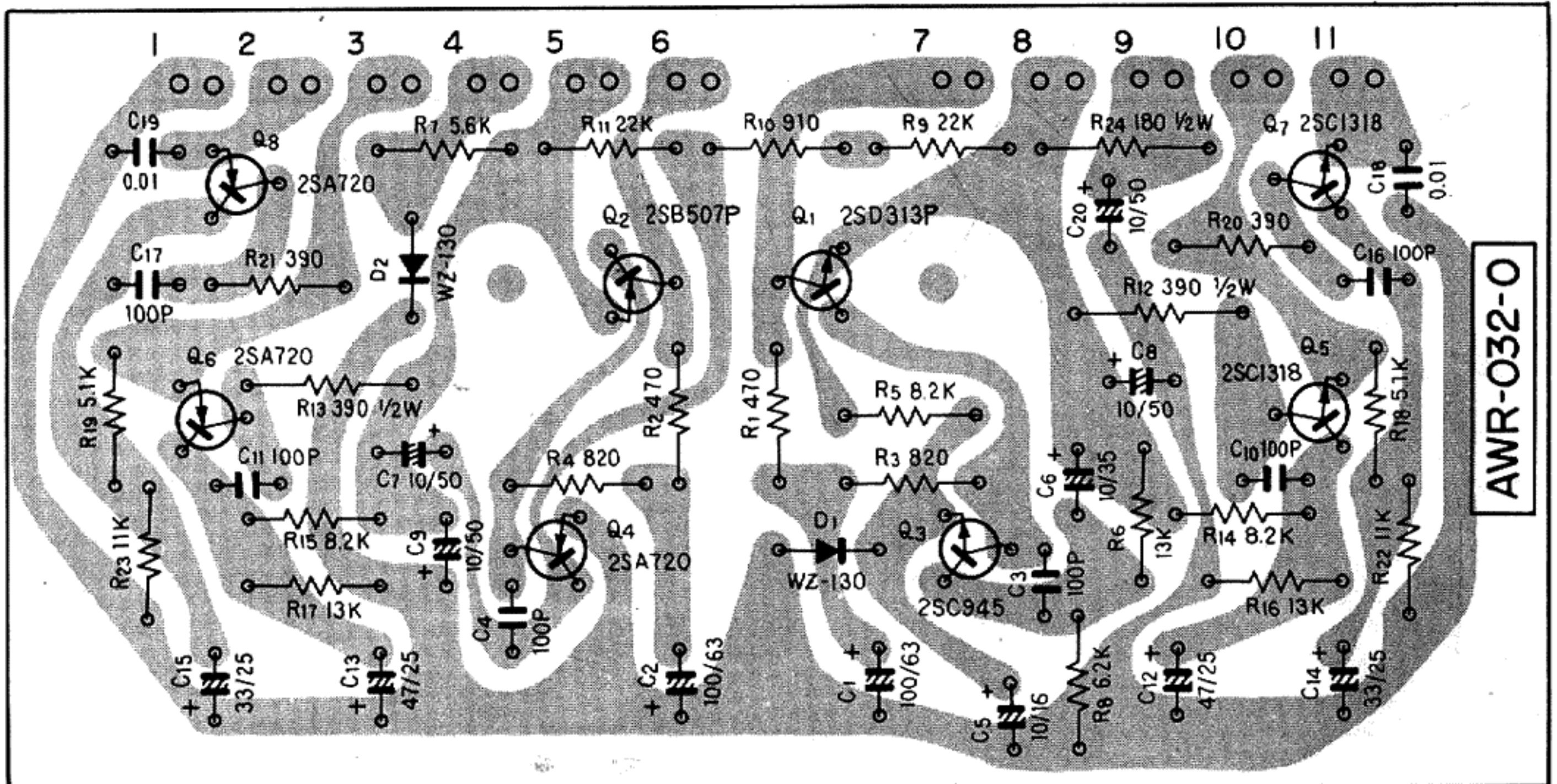

Parts List of Power Supply Circuit-B Ass'y (AWR-032-0)

CAPACITORS

Symbol	Description	Part No.
C1	Electrolytic 100 63V	CEA 101P 63-85C
C2	Electrolytic 100 63V	CEA 101P 63-85C
C3	Ceramic 100p 50V	CCDSL 101K 50
C4	Ceramic 100p 50V	CCDSL 101K 50
C5	Electrolytic 10 16V	CEA 100P 16-85C
C6	Electrolytic 10 35V	CEA 100P 35-85C
C7	Electrolytic 10 50V	CEA 100P 50-85C
C8	Electrolytic 10 50V	CEA 100P 50-85C
C9	Electrolytic 10 50V	CEA 100P 50-85C
C10	Ceramic 100p 50V	CCDSL 101K 50
C11	Ceramic 100p 50V	CCDSL 101K 50
C12	Electrolytic 47 25V	CEA 470P 25-85C
C13	Electrolytic 47 25V	CEA 470P 25-85C
C14	Electrolytic 33 25V	CEA 330P 25-85C
C15	Electrolytic 33 25V	CEA 330P 25-85C
C16	Ceramic 100p 50V	CCDSL 101K 50
C17	Ceramic 100p 50V	CCDSL 101K 50
C18	Ceramic 0.01 50V	CKDYF 103Z 50
C19	Ceramic 0.01 50V	CKDYF 103Z 50
C20	Electrolytic 10 50V	CEA 100P 50-85C

RESISTORS

Symbol	Description	Part No.
R1	Carbon film 470	RD $\frac{1}{4}$ PM 471J
R2	Carbon film 470	RD $\frac{1}{4}$ PM 471J
R3	Carbon film 820	RD $\frac{1}{4}$ PM 821J
R4	Carbon film 820	RD $\frac{1}{4}$ PM 821J
R5	Carbon film 8.2k	RD $\frac{1}{4}$ PM 822J
R6	Carbon film 13k	RD $\frac{1}{4}$ PM 133J
R7	Carbon film 5.6k	RD $\frac{1}{4}$ PM 562J
R8	Carbon film 6.2k	RD $\frac{1}{4}$ PM 622J
R9	Carbon film 22k	RD $\frac{1}{4}$ PM 223J
R10	Carbon film 910	RD $\frac{1}{4}$ PM 911J
R11	Carbon film 22k	RD $\frac{1}{4}$ PM 223J
R12	Carbon film 390 $\frac{1}{2}$ W	RD $\frac{1}{2}$ PM 391J
R13	Carbon film 390 $\frac{1}{2}$ W	RD $\frac{1}{2}$ PM 391J
R14	Carbon film 8.2k	RD $\frac{1}{4}$ PM 822J
R15	Carbon film 8.2k	RD $\frac{1}{4}$ PM 822J
R16	Carbon film 13k	RD $\frac{1}{4}$ PM 133J
R17	Carbon film 13k	RD $\frac{1}{4}$ PM 133J
R18	Carbon film 5.1k	RD $\frac{1}{4}$ PM 512J
R19	Carbon film 5.1k	RD $\frac{1}{4}$ PM 512J
R20	Carbon film 390	RD $\frac{1}{4}$ PM 391J
R21	Carbon film 390	RD $\frac{1}{4}$ PM 391J
R22	Carbon film 11k	RD $\frac{1}{4}$ PM 113J
R23	Carbon film 11k	RD $\frac{1}{4}$ PM 113J
R24	Carbon film 180 $\frac{1}{2}$ W	RD $\frac{1}{2}$ PM 181J

SEMICONDUCTORS

Symbol	Description	Part No.	
Q1	Transistor 2SD313P-D or E		
Q2	Transistor 2SB507P-D or E		
Q3	Transistor 2SC945-R or S		
Q4	Transistor 2SA720-R or Q		
Q5	Transistor 2SC1318-R or Q		
Q6	Transistor 2SA720-R or Q		
Q7	Transistor 2SC1318-R or Q		
Q8	Transistor 2SA720-R or Q		
D1	Zener diode WZ-130		
D2	Zener diode WZ-130		

OTHER

Symbol	Description	Part No.	
	Heat sink (2SD313P) (2SB507P)	ANH-117-0	

11.9 SWITCH-A ASS'Y (AWS-038-0)

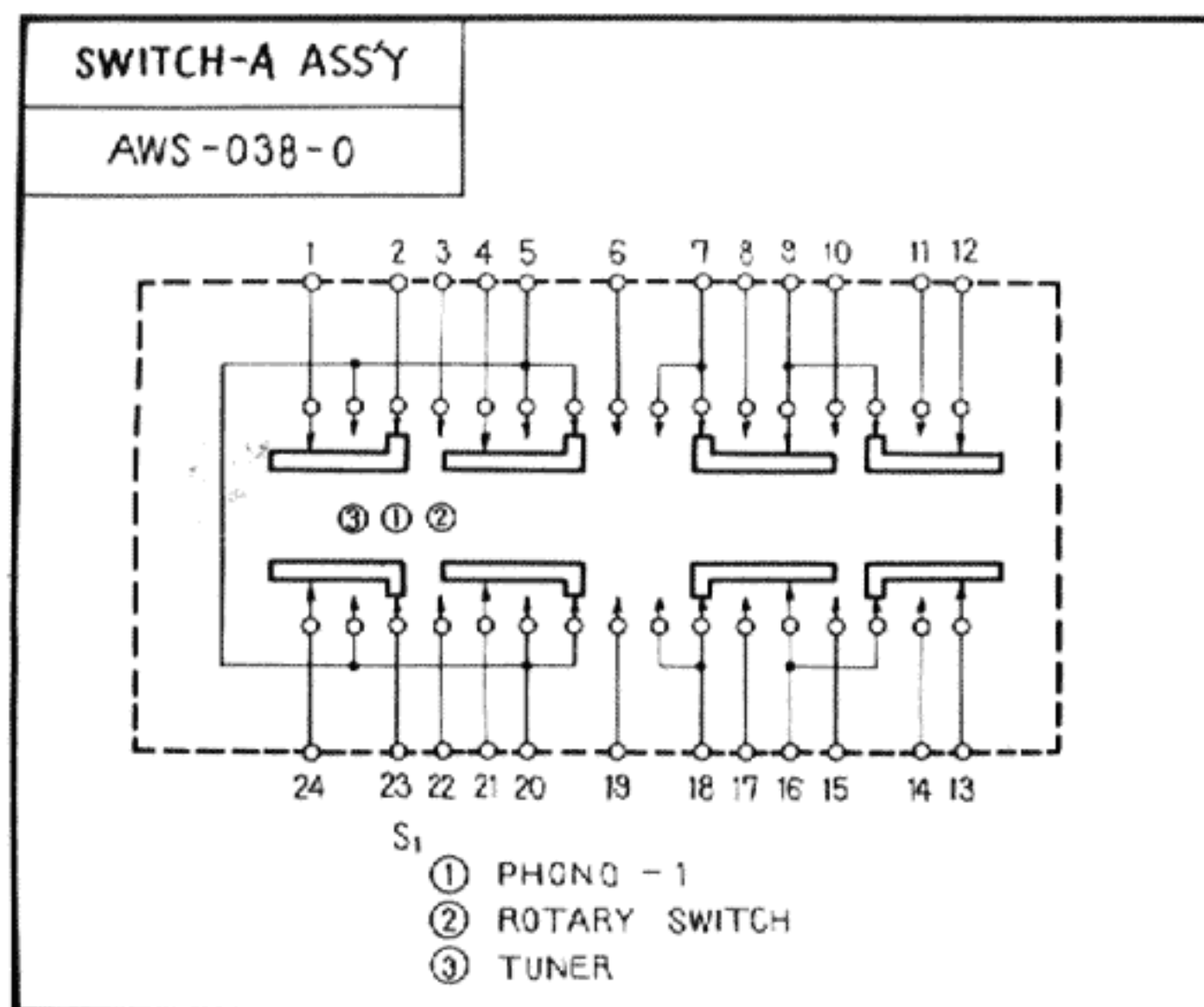

Foil Side

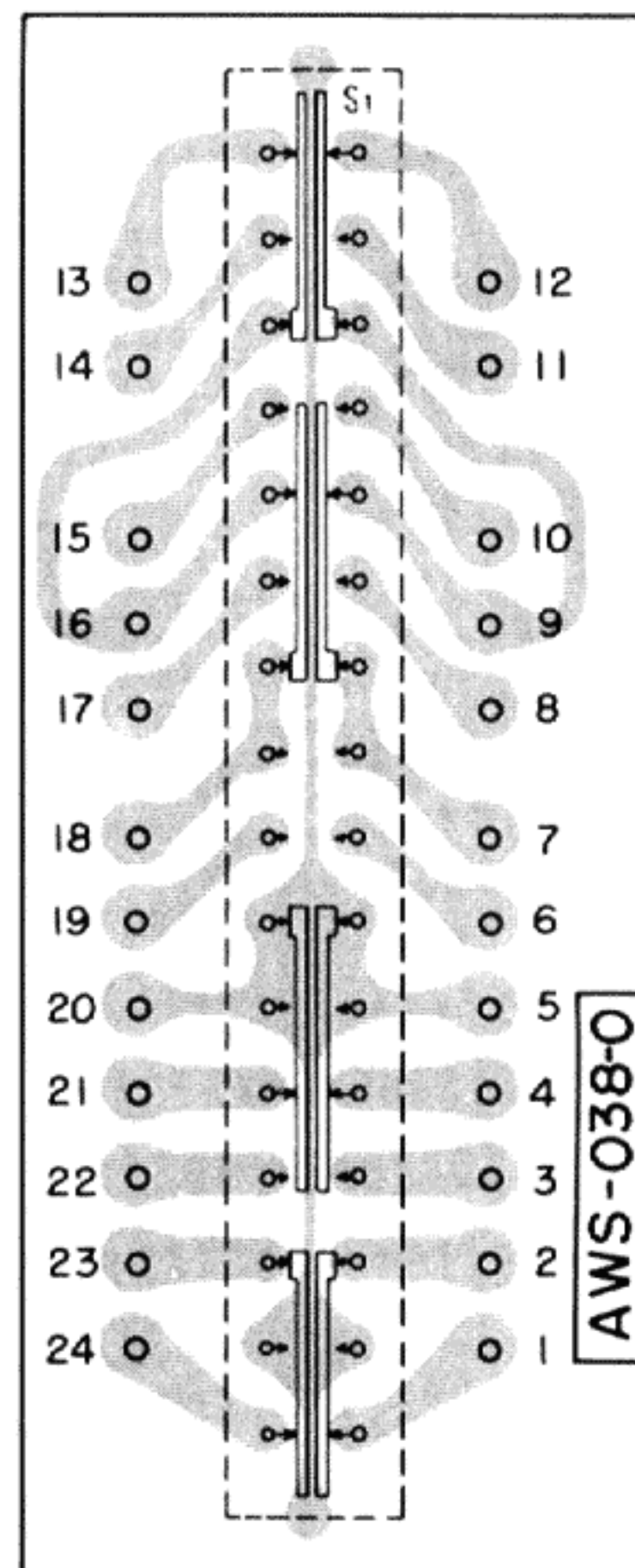

SWITCH

Symbol	Description	Part No.	
S1	Lever switch (FUNCTION)	ASK-037-A	

11.10 SWITCH-B ASS'Y (AWS-039-0)

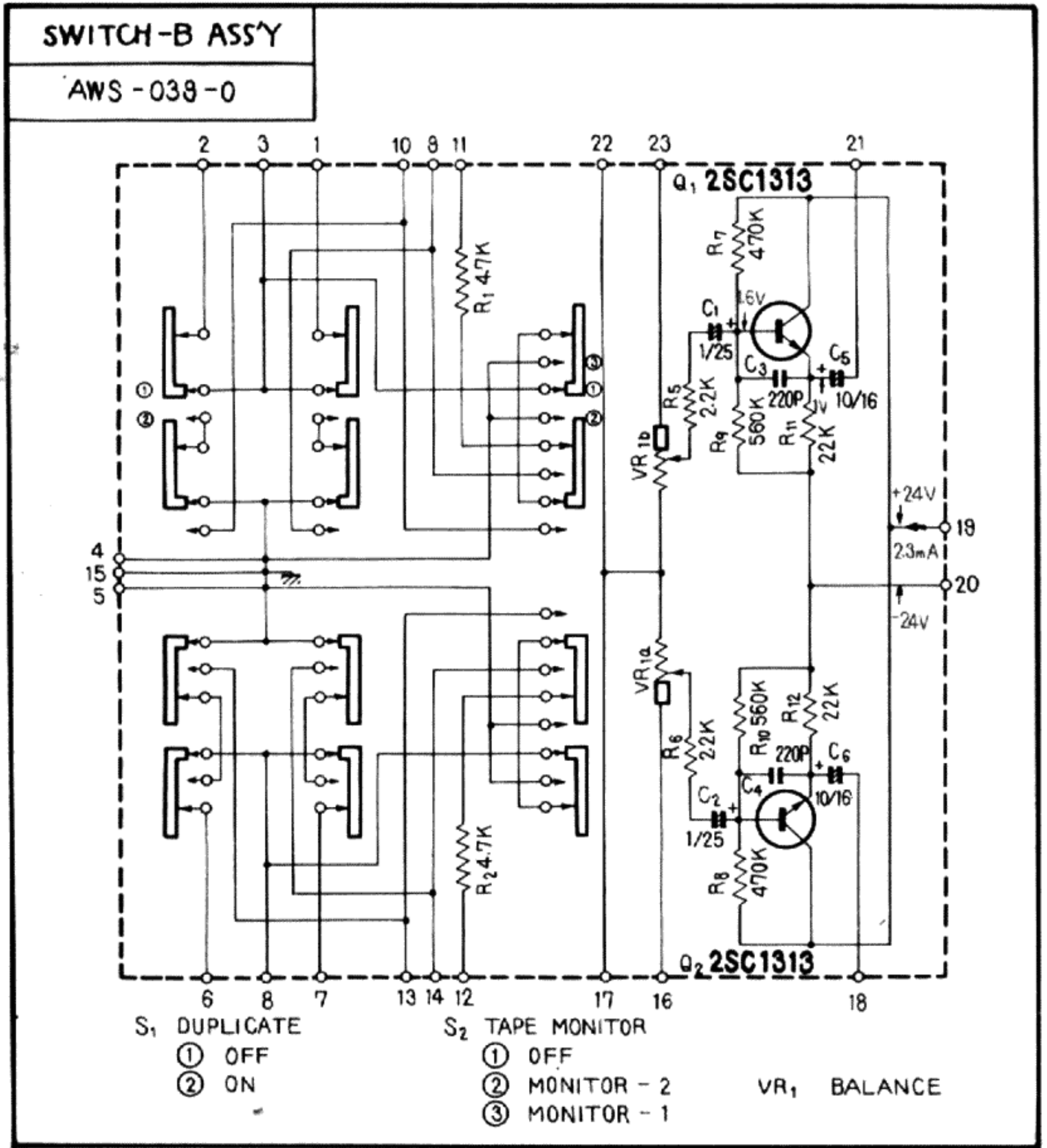

Foil Side

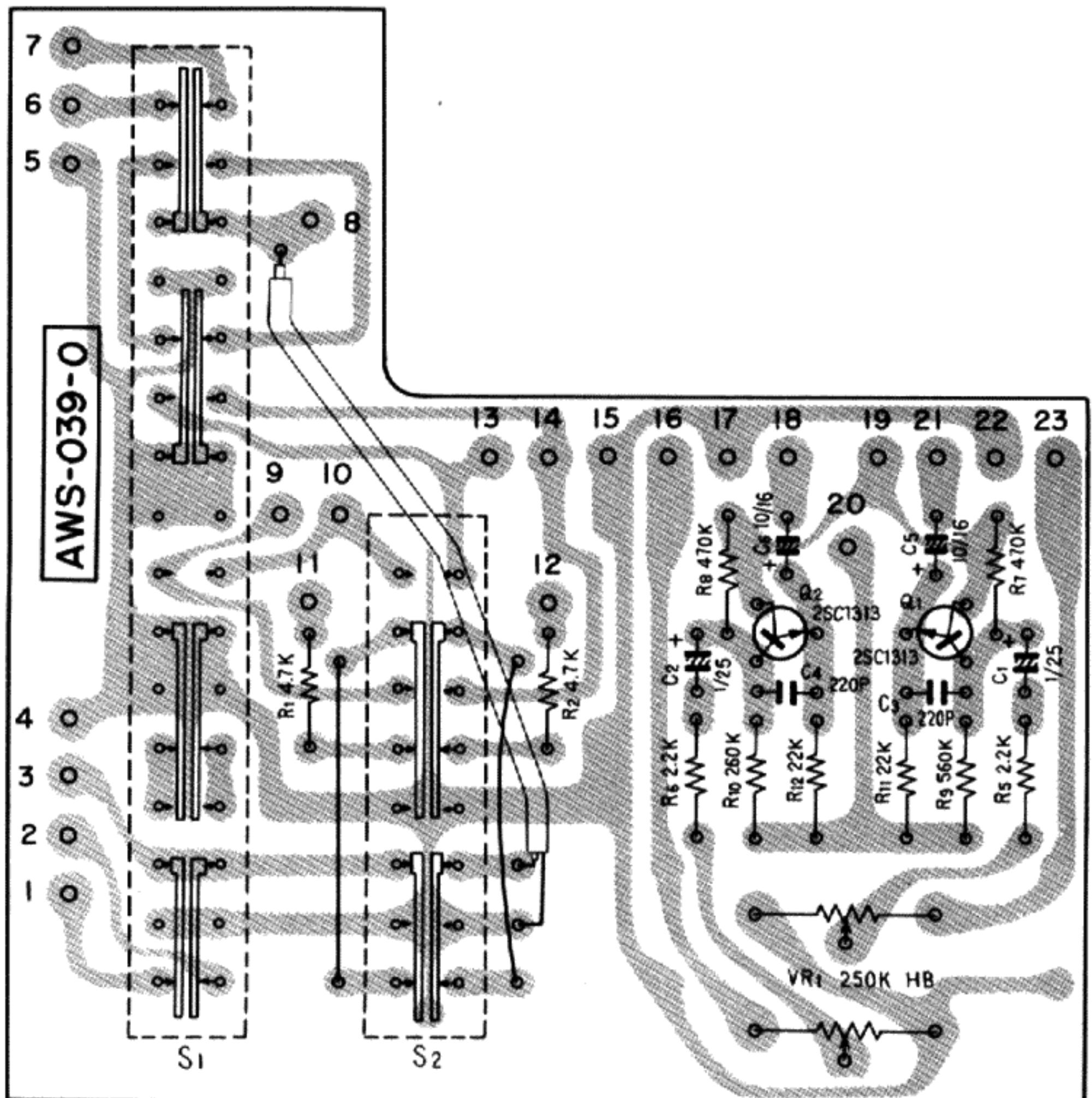

Parts List of Switch-B Ass'y (AWS-039-0)

CAPACITORS

Symbol	Description	Part No.
C1	Electrolytic 1 25V	CSSA 010M 25
C2	Electrolytic 1 25V	CSSA 010M 25
C3	Ceramic 220p 50V	CCDSL 221K 50
C4	Ceramic 220p 50V	CCDSL 221K 50
C5	Electrolytic 10 16V	CEA 100P 16
C6	Electrolytic 10 16V	CEA 100P 16

RESISTORS

Symbol	Description	Part No.
R1	Carbon film 4.7k	RD¼PM 472J
R2	Carbon film 4.7k	RD¼PM 472J
R5	Carbon film 2.2k	RD¼PM 222J
R6	Carbon film 2.2k	RD¼PM 222J
R7	Carbon film 470k	RD¼PM 474J
R8	Carbon film 470k	RD¼PM 474J
R9	Carbon film 560k	RD¼PM 564J
R10	Carbon film 560k	RD¼PM 564J
R11	Carbon film 22k	RD¼PM 223J
R12	Carbon film 22k	RD¼PM 223J

SEMICONDUCTORS

Symbol	Description	Part No.
Q1	Transistor 2SC1313-G or F (2SC1345-D or E)	
Q2	Transistor 2SC1313-G or F (2SC1345-D or E)	

SWITCHES

Symbol	Description	Part No.
S1	Lever switch (DUPLICATE)	ASK-036-0
S2	Lever switch (TAPE MONITOR)	ASK-034-0

POTENTIOMETER

Symbol	Description	Part No.
VR1	Balance control 250k-HB	ACV-111-A

11.11 SWITCH-C Ass'y (AWS-040-0)

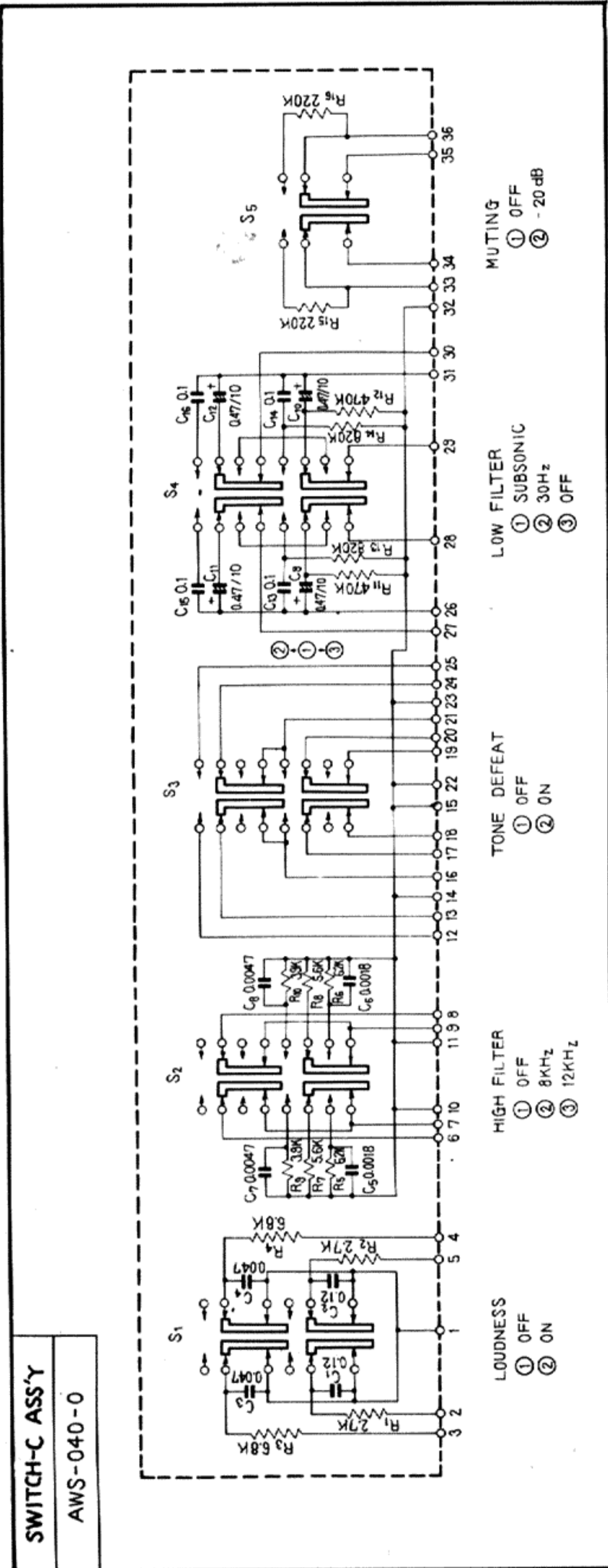

Foil side

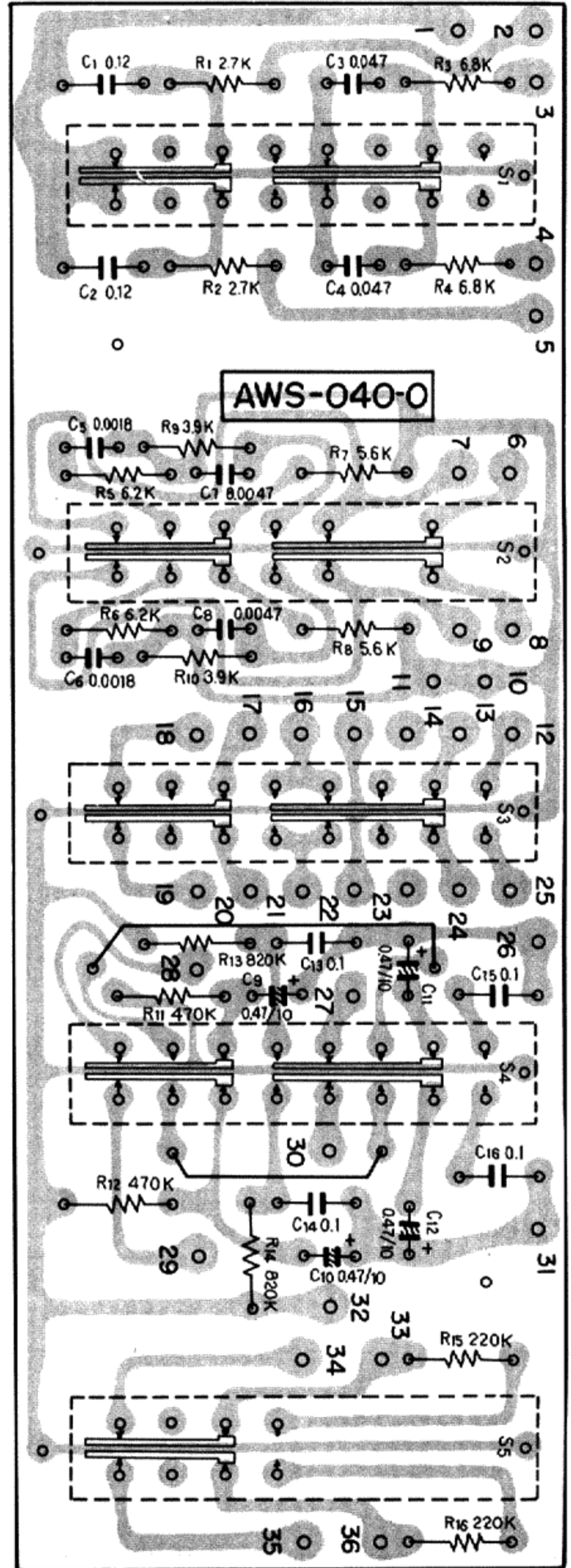

Parts List of Switch -C ASS'Y (AWS-040-0)

CAPACITORS

Symbol	Description	Part No.
C1	Mylar 0.12 50V	CQMA 124J 50
C2	Mylar 0.12 50V	CQMA 124J 50
C3	Mylar 0.047 50V	CQMA 473J 50
C4	Mylar 0.047 50V	CQMA 473J 50
C5	Mylar 0.0018 50V	CQMA 182J 50
C6	Mylar 0.0018 50V	CQMA 182J 50
C7	Mylar 0.0047 50V	CQMA 472J 50
C8	Mylar 0.0047 50V	CQMA 472J 50
C9	Electrolytic 0.47 10V	CSSA R47M 10
C10	Electrolytic 0.47 10V	CSSA R47M 10
C11	Electrolytic 0.47 10V	CSSA R47M 10
C12	Electrolytic 0.47 10V	CSSA R47M 10
C13	Mylar 0.1 50V	CQMA 104J 50
C14	Mylar 0.1 50V	CQMA 104J 50
C15	Mylar 0.1 50V	CQMA 104J 50
C16	Mylar 0.1 50V	CQMA 104J 50

RESISTORS

Symbol	Description	Part No.
R1	Carbon film 2.7k	RD¼PM 272J
R2	Carbon film 2.7k	RD¼PM 272J
R3	Carbon film 6.8k	RD¼PM 682J
R4	Carbon film 6.8k	RD¼PM 682J
R5	Carbon film 6.2k	RD¼PM 622J
R6	Carbon film 6.2k	RD¼PM 622J
R7	Carbon film 5.6k	RD¼PM 562J
R8	Carbon film 5.6k	RD¼PM 562J
R9	Carbon film 3.9k	RD¼PM 392J
R10	Carbon film 3.9k	RD¼PM 392J
R11	Carbon film 470k	RD¼PM 474J
R12	Carbon film 470k	RD¼PM 474J
R13	Carbon film 820k	RD¼PM 824J
R14	Carbon film 820k	RD¼PM 824J
R15	Carbon film 220k	RD¼PM 224J
R16	Carbon film 220k	RD¼PM 224J

SWITCHES

Symbol	Description	Part No.
S1	Lever switch (LOUDNESS)	ASK-033-0
S2	Lever switch (HIGH FILTER)	ASK-035-0
S3	Lever switch (TONE DEFEAT)	ASK-033-0
S4	Lever switch (LOW FILTER)	ASK-035-0
S5	Lever switch (MUTING)	ASK-030-0

11.12 VOLUME ASS'Y (AWX-048-0)

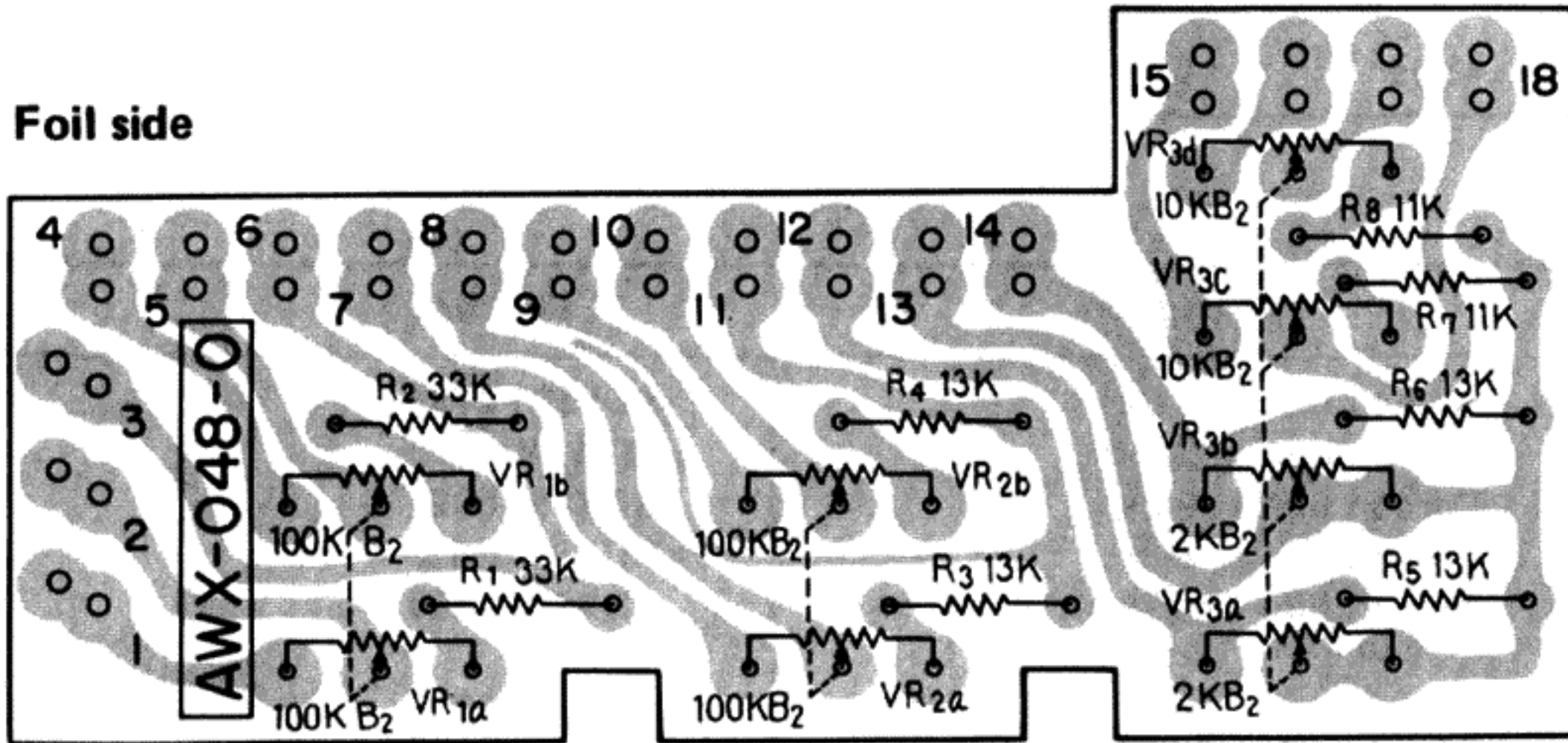
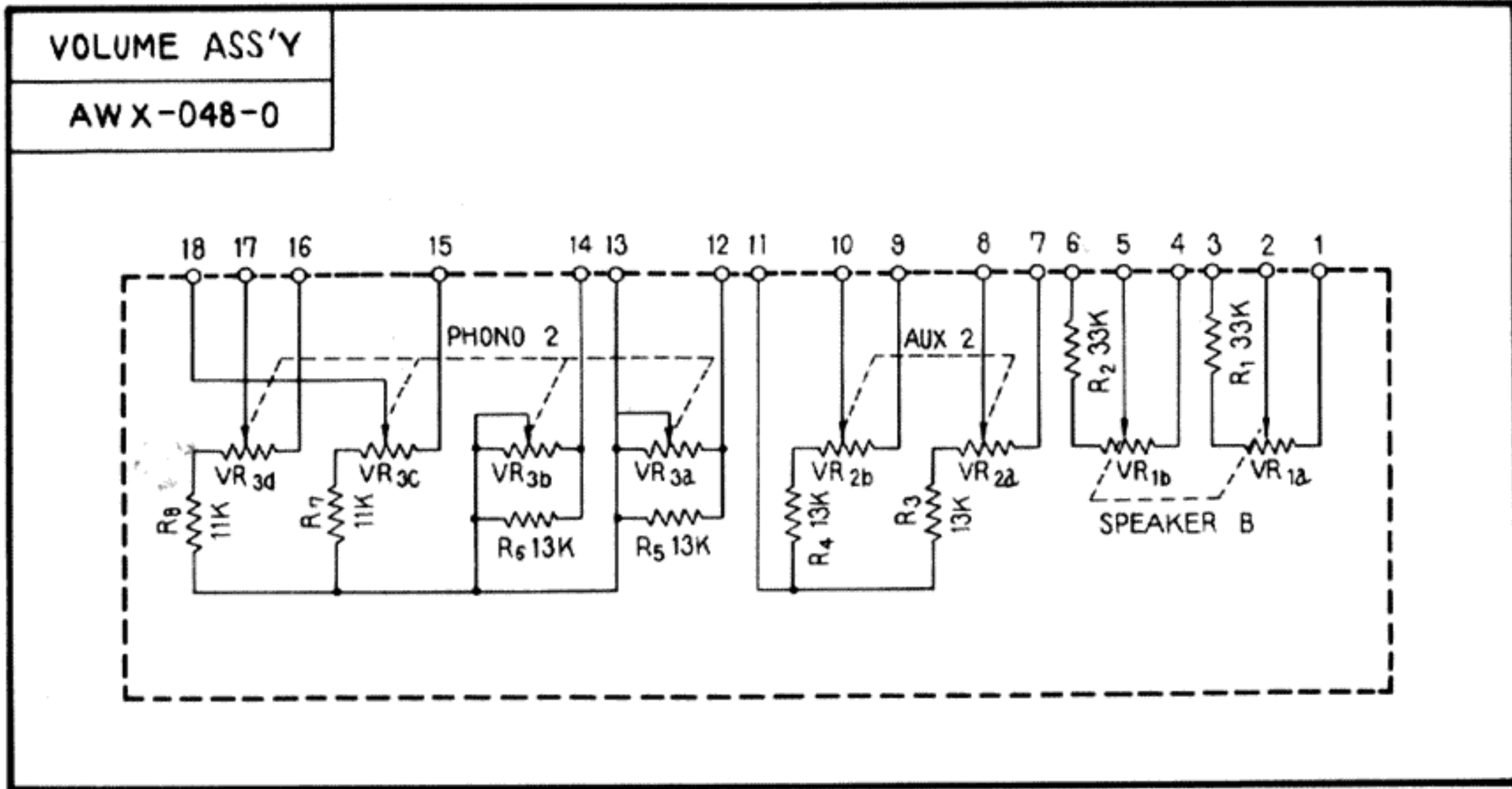

RESISTORS

Symbol	Description	Part No.	
R1	Carbon film 33k	RD¼PM 333J	
R2	Carbon film 33k	RD¼PM 333J	
R3	Carbon film 13k	RD¼PM 133J	
R4	Carbon film 13k	RD¼PM 133J	
R5	Carbon film 13k	RD¼PM 133J	
R6	Carbon film 13k	RD¼PM 133J	
R7	Carbon film 11k	RD¼PM 113J	
R8	Carbon film 11k	RD¼PM 113J	





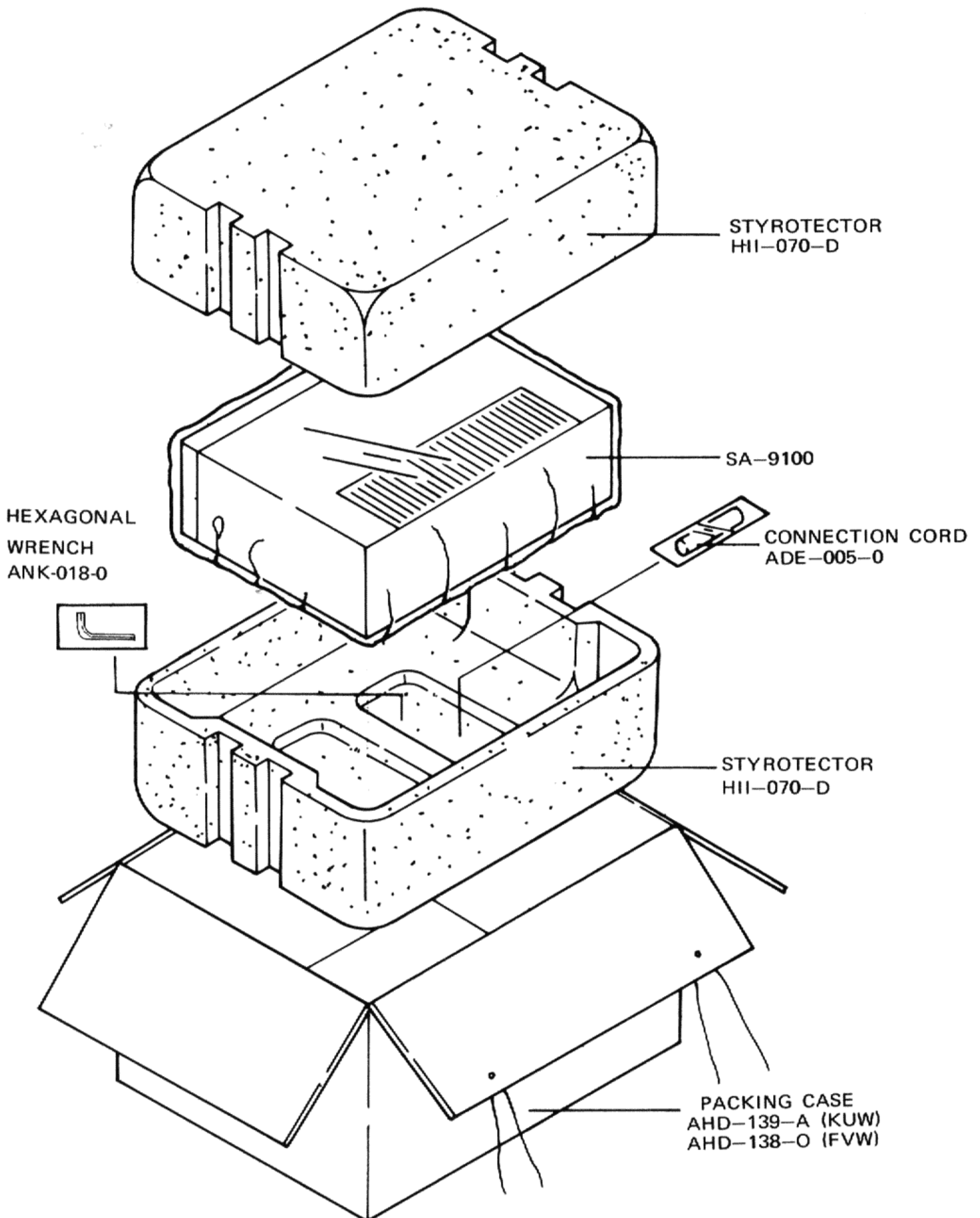

POTENTIOMETERS

Symbol	Description	Part No.	
VR1	Level control (100k-B ₂ x 2)	ACT-104-0	AUX 2
VR2	Level control (100k-B ₂ x 2)	ACT-104-0	SPEAKER B
VR3	Level control (10k-B ₂ x2, 2.2k-B ₂ x2)	ACT-302-A	PHONO 2

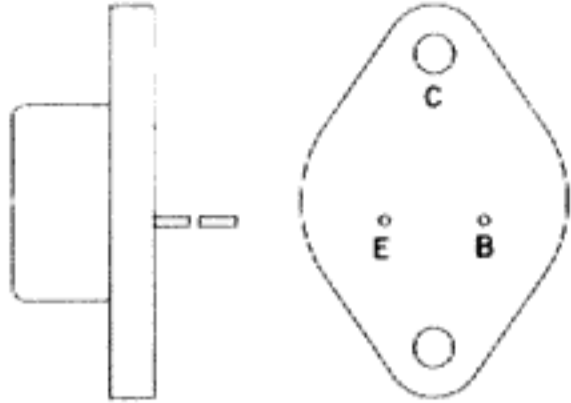
12. PACKING METHOD AND PARTS NUMBERS

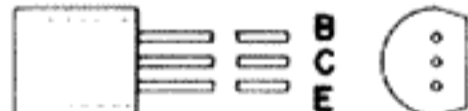
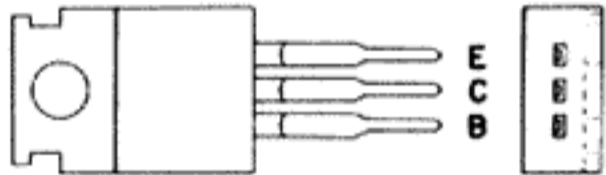
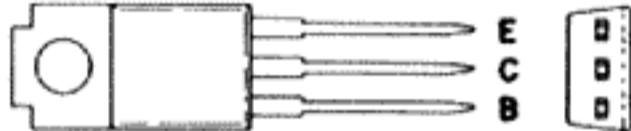

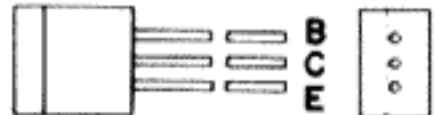
13. SKELETON APPEARANCES OF TRANSISTORS

<p>2SA628A 2SA720R 2SC1318</p>		<p>2SA679 2SC1079</p>	
<p>2SA733</p>		<p>2SA774 2SA774A 2SC1478</p>	
<p>2SA726 2SC869 2SC1313 2SC1312</p>		<p>2SB507P 2SD313P</p>	
<p>2SB528 2SD358</p>		<p>2SC857K</p>	
<p>2SC945</p>		<p>2SC1345</p>	
<p>2SC1384</p>		<p>2SC1451</p>	