

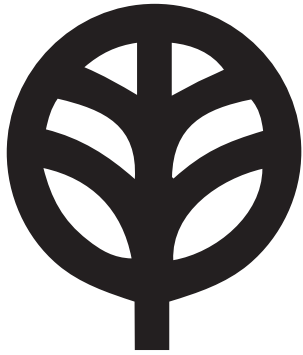

For more Hi-Fi manuals and set-up information
please visit www.hifiengine.com



KENWOOD
HI/FI STEREO COMPONENTS

SERVICE MANUAL

KA-7002

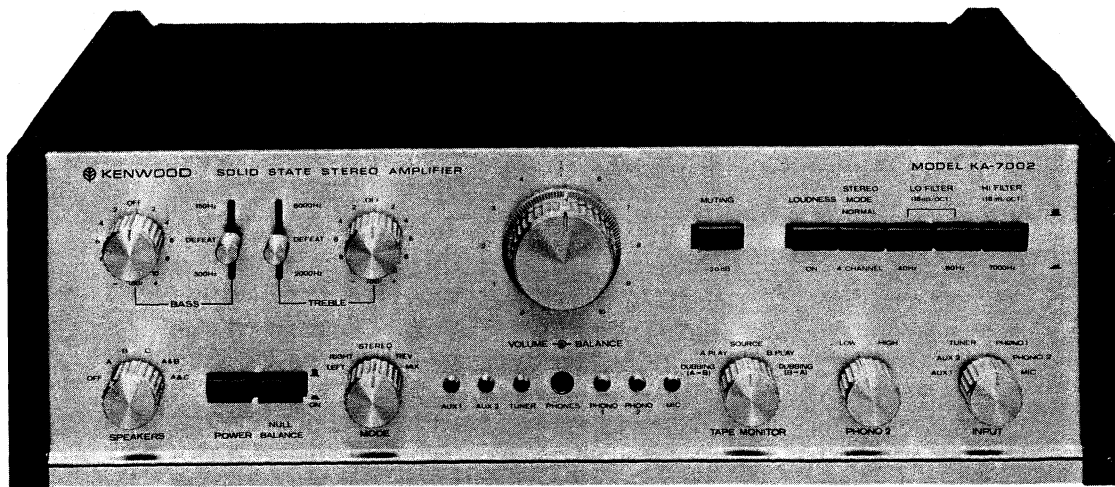

SOLID STATE STEREO AMPLIFIER

PARTS DESCRIPTION LIST

Symbol No.	Description	Part No.	Remarks
MAIN CHASSIS (Y08-0059-00) SECTION			
-	LOW LEVEL	X08-0011-02	
-	PRE	X08-0015-11	
-	TONE	X09-0004-13	
-	HIGH FILTER	X12-0035-00	
-	LOW FILTER	X12-0036-00	
-	MAIN	X07-0027-00	
-	PROTECTION	X13-1010-11	
CAPACITOR			
C131, 132	Mylar	330pF ±5%	CQ92M1H331J
C133	Mylar	0.001μF ±5%	CQ92M1H102J
C134	Electrolytic	3.3μF 6.3WV	C90-0081-05
C135, 136	Mylar	0.1μF ±10%	CQ92M1H104K
C137, 138	Mylar	0.0012μF ±10%	CQ92M1H122K
C139	Electrolytic	3.3μF 6.3WV	C90-0081-05
C171	Electrolytic	0.22μF ±20%	CQ92M1H224M
C231, 232	Mylar	330pF ±5%	CQ92M1H331J
C233	Mylar	0.001μF ±5%	CQ92M1H102J
C234	Electrolytic	3.3μF 6.3WV	C90-0081-05
C235, 236	Mylar	0.1μF ±10%	CQ92M1H104K
C237, 238	Mylar	0.0012μF ±10%	CQ92M1H122K
C271	Mylar	0.22μF ±20%	CQ92M1H224M
C239	Electrolytic	3.3μF 6.3WV	C90-0081-05
C301	Oil Impregnated (K)	0.01μF ±20%	C90-0036-05
C301	Oil Impregnated (U)	0.01μF ±20%	CP02B2J103M
C302 ~ 304	Oil Impregnated	0.022μF ±20%	CP02B2J223M
C305, 306	Electrolytic	4000μF 75WV	C90-0084-05
C307	Electrolytic	1000μF 80WV	C90-0075-05
C308	Electrolytic	100μF 50WV	CE02W2A101
C309	Electrolytic	470μF 50WV	CE02W1H471
C310	Electrolytic	470μF 35WV	CE02W1V471
C311	Electrolytic	470μF 25WV	CE02W1E471
C312	Oil Impregnated	0.022μF ±20%	CP02B2J223M
C313	Ceramic	0.04μF +80% -20%	CK94YG1E403Z
RESISTOR			
R101	Insulated Carbon Film	390kΩ ±10% 1/4W	PD14BY2E394K
R102	Insulated Carbon Film	100kΩ ±10% 1/4W	PD14BY2E104K
R103	Insulated Carbon Film	390kΩ ±10% 1/4W	PD14BY2E394K
R104	Insulated Carbon Film	100kΩ ±10% 1/4W	PD14BY2E104K
R105	Insulated Carbon Film	82kΩ ±10% 1/4W	PD14BY2E823K
R111	Insulated Carbon Film	47Ω ±10% 1/4W	PD14BY2E470K
R112	Insulated Carbon Film	10kΩ ±10% 1/4W	PD14BY2E103K
R113	Insulated Carbon Film	18kΩ ±10% 1/4W	PD14BY2E183K
R114, 115	Insulated Carbon Film	15kΩ ±5% 1/4W	PD14BY2E153J
R116, 117	Insulated Carbon Film	12kΩ ±5% 1/4W	PD14BY2E123J
R118, 119	Insulated Carbon Film	7.5kΩ ±5% 1/4W	PD14BY2E752J
R120, 121	Insulated Carbon Film	5.6kΩ ±5% 1/4W	PD14BY2E562J
R122, 123	Insulated Carbon Film	3.3kΩ ±5% 1/4W	PD14BY2E332J
R124, 125	Insulated Carbon Film	15kΩ ±5% 1/4W	PD14BY2E153J
R126, 127	Insulated Carbon Film	12kΩ ±5% 1/4W	PD14BY2E123J
R128, 129	Insulated Carbon Film	7.5kΩ ±5% 1/4W	PD14BY2E752J

PARTS DESCRIPTION LIST

Symbol No.	Description	Part No.	Remarks
R130, 131	Insulated Carbon Film 5.6kΩ ±5% 1/4W	PD14BY2E562J	
R132, 133	Insulated Carbon Film 3.3kΩ ±5% 1/4W	PD14BY2E332J	
R134	Insulated Carbon Film 22kΩ ±10% 1/4W	PD14BY2E223K	
R135, 136	Insulated Carbon Film 56kΩ ±10% 1/4W	PD14BY2E563K	
R137, 138	Insulated Carbon Film 10kΩ ±10% 1/4W	PD14BY2E103K	
R139, 140	Insulated Carbon Film 3.9kΩ ±10% 1/4W	PD14BY2E392K	
R141, 142	Insulated Carbon Film 27kΩ ±10% 1/4W	PD14BY2E273K	
R143	Insulated Carbon Film 47Ω ±10% 1/4W	PD14BY2E470K	
R171, 172	Cement 0.47Ω ±10% 3W	R92-0003-05	
R173	Metal Film 4.7Ω ±10% 2W	RNAB3D4R7K	
R174	Fixed Carbon Composition 560Ω ±10% 1/2W	RC05GF2H561K	
R175	Fixed Carbon Composition 1kΩ ±10% 1/2W	RC05GF2H102K	
R180	Fixed Carbon Composition 56Ω ±10% 1/2W	RC05GF2H560K	
R201	Insulated Carbon Film 390kΩ ±10% 1/4W	PD14BY2E394K	
R202	Insulated Carbon Film 100kΩ ±10% 1/4W	PD14BY2E104K	
R203	Insulated Carbon Film 390kΩ ±10% 1/4W	PD14BY2E394K	
R204	Insulated Carbon Film 100kΩ ±10% 1/4W	PD14BY2E104K	
R205	Insulated Carbon Film 82kΩ ±10% 1/4W	PD14BY2E823K	
R211	Insulated Carbon Film 47Ω ±10% 1/4W	PD14BY2E470K	
R212	Insulated Carbon Film 10kΩ ±10% 1/4W	PD14BY2E103K	
R213	Insulated Carbon Film 18kΩ ±10% 1/4W	PD14BY2E183K	
R214, 215	Insulated Carbon Film 15kΩ ±5% 1/4W	PD14BY2E153J	
R216, 217	Insulated Carbon Film 12kΩ ±5% 1/4W	PD14BY2E123J	
R218, 219	Insulated Carbon Film 7.5kΩ ±5% 1/4W	PD14BY2E752J	
R220, 221	Insulated Carbon Film 5.6kΩ ±5% 1/4W	PD14BY2E562J	
R222, 223	Insulated Carbon Film 3.3kΩ ±5% 1/4W	PD14BY2E332J	
R224, 225	Insulated Carbon Film 15kΩ ±5% 1/4W	PD14BY2E153J	
R226, 227	Insulated Carbon Film 12kΩ ±5% 1/4W	PD14BY2E123J	
R228, 229	Insulated Carbon Film 7.5kΩ ±5% 1/4W	PD14BY2E752J	
R230, 231	Insulated Carbon Film 5.6kΩ ±5% 1/4W	PD14BY2E562J	
R232, 233	Insulated Carbon Film 3.3kΩ ±5% 1/4W	PD14BY2E332J	
R234	Insulated Carbon Film 22kΩ ±5% 1/4W	PD14BY2E223K	
R235, 236	Insulated Carbon Film 56kΩ ±10% 1/4W	PD14BY2E561K	
R237, 238	Insulated Carbon Film 10kΩ ±10% 1/4W	PD14BY2E103K	
R239, 240	Insulated Carbon Film 3.9kΩ ±10% 1/4W	PD14BY2E392K	
R241, 242	Insulated Carbon Film 27kΩ ±10% 1/4W	PD14BY2E273K	
R243	Insulated Carbon Film 47Ω ±10% 1/4W	PD14BY2E470K	
R271, 272	Cement 0.47Ω ±10% 3W	R92-0003-05	
R273	Metal Film 4.7Ω ±10% 2W	RNAB3D4R7K	
R274	Fixed Carbon Composition 560Ω ±10% 1/2W	RC05GF2H561K	
R275	Fixed Carbon Composition 1kΩ ±10% 1/2W	RC05GF2H102K	
R302	Fixed Carbon Composition 22kΩ ±10% 1/2W	RC05GF2H223K	
R303	Fixed Carbon Composition 1kΩ ±10% 1/2W	RC05GF2H102K	
R304	Fixed Carbon Composition 6.8kΩ ±10% 1/2W	RC05GF2H682K	
SWITCH			
S1	PHONO 2 (Rotary) F · 1 · 6 · 2	S01-1003-15	
S2	SELECTOR (Rotary) F · 4 · 9 · 6	S01-4001-15	
S3	TAPE MONI. (Rotary) F · 2 · 6 · 5	S01-2002-05	
S4	MODE (Rotary) F · 1 · 2 · 5	S01-1004-05	
S5	BASS (Rotary) F · 2 · 4 · 11	S01-2005-05	
S6	TREBLE (Rotary) F · 2 · 2 · 11	S01-2003-05	
S7	SPEAKERS (Rotary) F · 2 · 6 · 6	S01-2004-05	

PARTS DESCRIPTION LIST

Symbol No.	Description	Part No.	Remarks
S8	POWER (Pushbutton)	S40-2012-05	
S9	TURNOVER (Lever) 2-4-3	S29-2002-05	
S10	TURNOVER (Lever) 1-2-3	S29-1054-05	
S11	MUTING (Six Pushbutton)	S41-6001-05	
S12	LOUDNESS (Six Pushbutton)	S41-6001-05	
S13	STEREO MODE (Six Pushbutton)	S41-6001-05	
S14	40Hz LOW FIL (Six Pushbutton)	S41-6001-05	
S15	80Hz LOW FIL (Six Pushbutton)	S41-6001-05	
S16	HIGH FIL (Six Pushbutton)	S41-6001-05	
S17	NULL BALANCE (Pushbutton)	S40-2014-05	
S18	PRE MAIN SEPARATE (Slide)	S31-2007-05	
S19	IMPEDANCE (Slide)	S31-2007-05	
S20	AC VOLTAGE SELECT (Slide)	S31-2004-05	
POTENTIOMETER			
VR1	VOLUME 50k Ω (B) Five-gang	R24-4001-05	
VR2	4 CHANNEL 50k Ω (B) Five-gang	R24-4001-05	
VR3	BALANCE 50k Ω (G) Five-gang	R24-4001-05	
TRANSISTOR/DIODE			
Q1, 2	2SA649		
Q3, 4	2SD218		
Q5	2SD234		
D1	5B1		
D2	10DC1		
D3, 4	STV-3		
etc.			
–	Case	A01-0134-03	
–	Chassis	A10-0236-01	
–	Panel	A20-0368-02	
–	Sub Panel	A22-0089-02	
–	Rear Panel	A23-0198-02	
–	Sole Plate	A40-0065-02	
–	Jewel	B08-6006-04	
–	Destination Sticker	B40-0458-04	
–	Certification	B42-0009-04	
–	LA Standard Sticker	B42-0220-00	
–	Warranty Card	B46-0013-00	
–	Warranty Card (U)	B46-0022-00	
–	Instruction Manual (K)	B50-0558-00	
–	Instruction Manual (U)	B50-0561-00	
–	Schematic Diagram	B52-0087-10	
–	Caution Card (U)	B58-0003-00	
–	Caution Card (U)	B58-0018-00	
–	Caution Card (K)	B58-0043-00	
–	Caution Card (U)	B58-0101-00	
–	Address (U)	B59-0018-00	
–	Switch Stopper (Power)	D32-0021-04	
–	Switch Stopper (PRE-MAIN)	D32-0034-04	
–	Transistor Socket x 4	E02-0207-05	
–	5P Connector x 2	E06-0501-05	
–	UL AC Outlet x 4	E08-0205-05	

PARTS DESCRIPTION LIST

Symbol No.	Description	Part No.	Remarks
—	Connector Socket (22P)	E10-2201-05	
J	Phone Jack (Headphone)	E11-0042-15	
J	Phone Jack (MIC) x 2	E11-0043-05	
J	1P Pin Jack	E13-0104-05	
J	8P Pin Jack x 2	E13-0802-05	
J	10P Pin Jack	E13-1002-05	
—	Shorted Pin x 2	E14-0107-05	
—	Pilot Lamp Socket	E15-0010-05	
—	Power Cord	E30-0046-05	
—	Radiator	F01-0045-03	
F	Fuse (4A)	F05-4022-05	
—	Lamp Cover	F07-0011-04	
—	Sub Panel Cover	F07-0188-03	
—	Shielding Plate (AMIN AMP)	F10-0195-03	
—	Shielding Plate	F10-0206-04	
—	Shielding Plate	F10-0212-04	
—	Shielding Case (PRE, FILTER)	F11-0125-03	
—	Shielding Case (LOW LEVEL)	F11-0126-03	
—	Dust Sheet	F15-0061-04	
—	Side Board	F19-0033-03	
—	Side Board	F19-0034-03	
—	Packing	G50-0011-04	
—	Corrugated Cordboard Case	H01-0553-03	
—	Corrugated Cordboard Case (K)	H02-0136-03	
—	Legs	J02-0049-14	
—	Fuse Holder	J13-0016-15	
—	Fuse Holder (Output)	J13-0023-05	
—	Varistor Holder	J19-0101-04	
—	PC Board Holder	J19-0107-14	
—	Amp. Holder	J21-0192-04	
—	Jewel Holder	J21-0438-04	
—	Radiator Holder	J21-0701-04	
—	Pin Jack Holder	J21-0749-04	
—	PC Board (Switch)	J25-0488-04	
—	Power Cord Bushing	J41-0006-00	
—	Knob (21 ϕ , BASS, TREBLE, SPEAKERS MODE, TAPE MONI., PHONO 2, INPUT)	K22-0020-04	
—	Knob (37.9 ϕ , VOLUME)	K23-0058-04	
—	Knob (49.5 ϕ , BALANCE)	K23-0059-04	
—	Knob (8.5 ϕ , BASS & TREBLE TURNOVER)	K29-0015-04	
P. T.	Power Transformer	L03-0039-15	
R. L.	Relay (24V, 36.9mA)	S51-2008-05	
	<i>In North America leave out the parts of "U"</i>		
	<i>In other area do out the parts of "K"</i>		

EXTERNAL VIEW

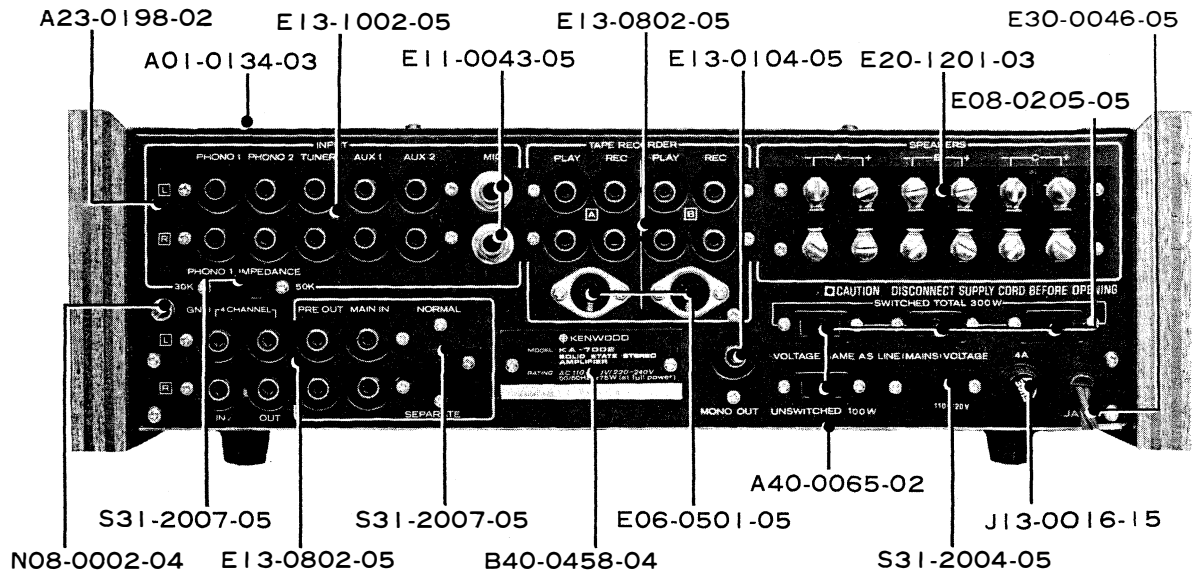
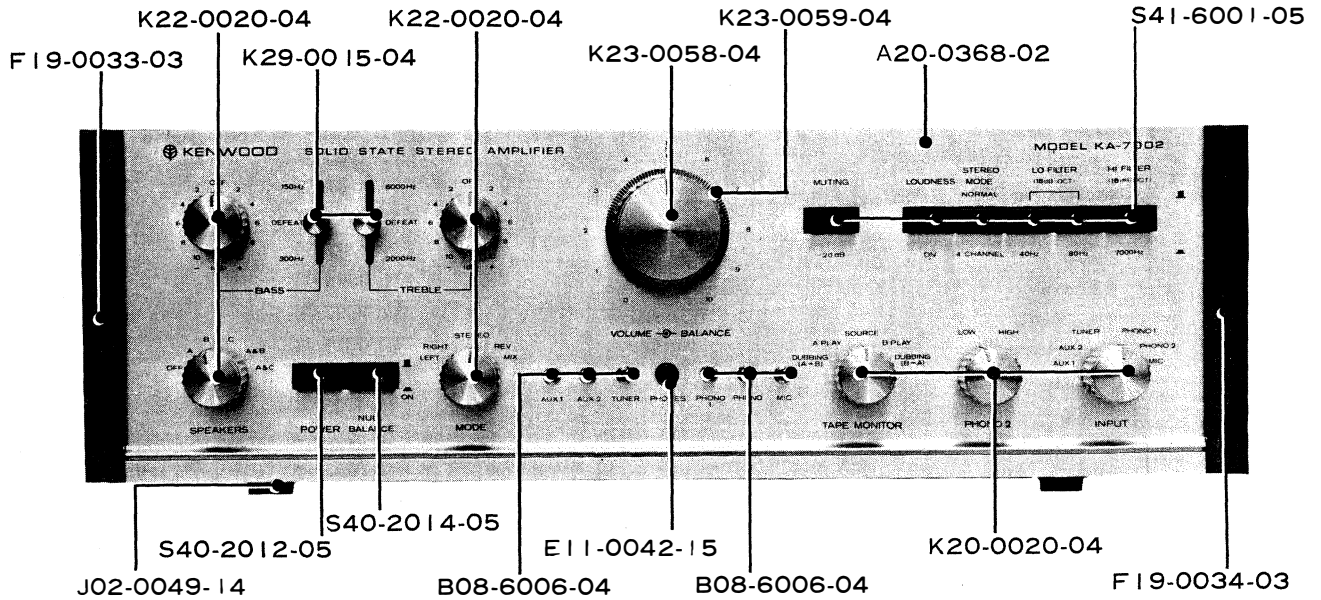

TOP & BOTTOM CHASSIS VIEW

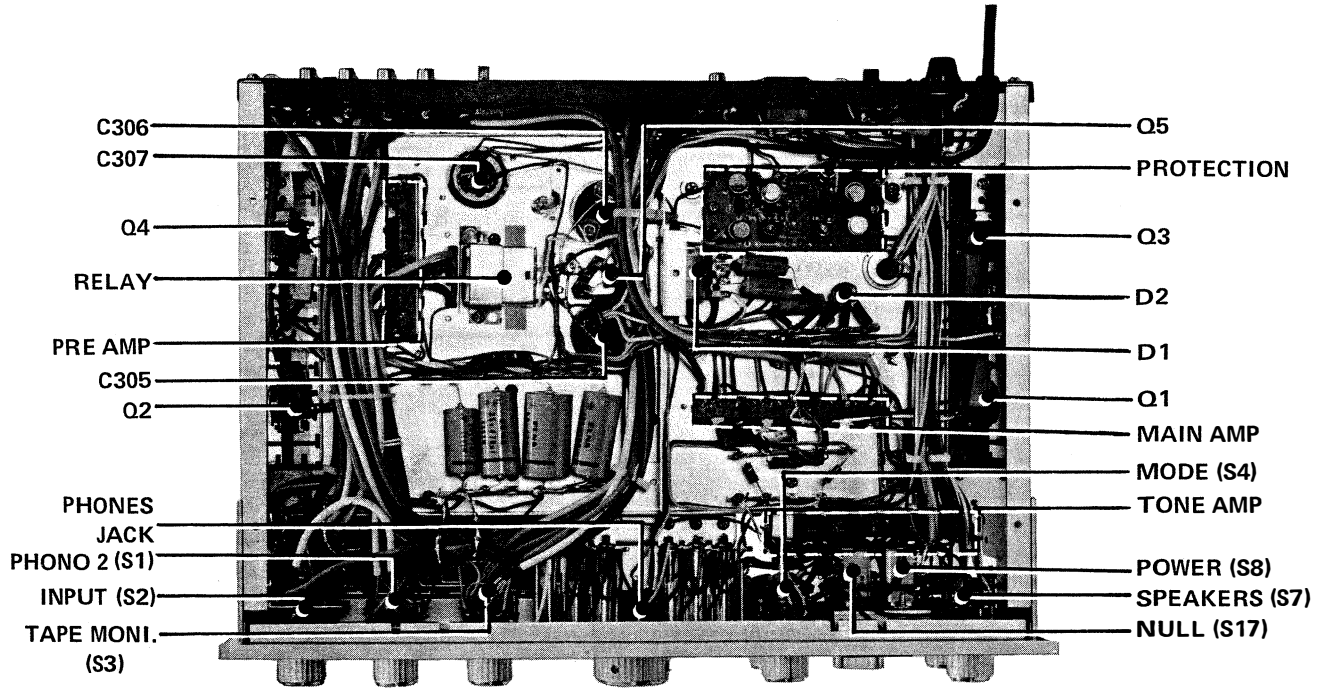
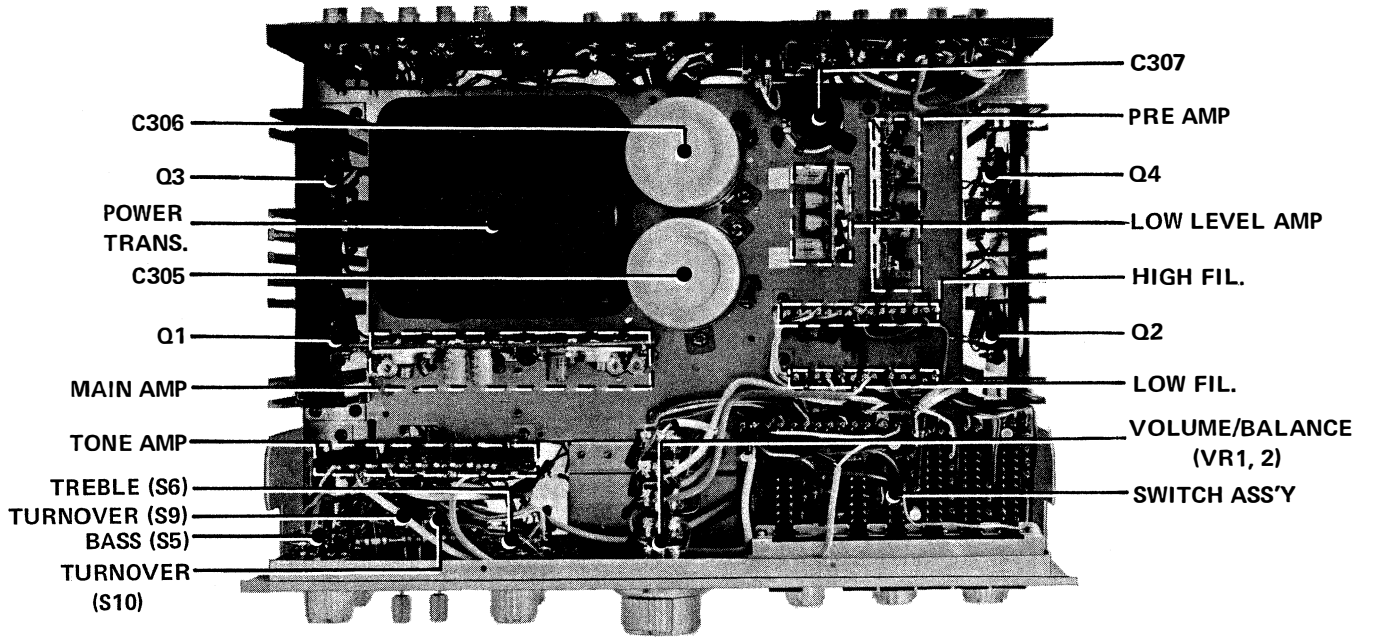

ALIGNMENT PROCEDURE

DIFFERENTIAL AMPLIFICATION STAGE

- Replacing the differential stage transistors (Q₁ ~ 8), should replace both the same characteristic transistors.
- Connect the dummy load (8Ω, 80 watts) to the output terminal.
 - Check the voltage across the dummy by using the tester or DC VTVM.
 - Adjust the * variable resistor (VR_q 1,2) so that the meter indicates within 0 ± 100 mV. (Fig. 1)
 - * Don't touch the variable resistor without necessity.

IDLING CURRENT

- Center voltage adjusting variable resistor (VR_q 1.2) in main unit is not turned without adjusting differential amplification stage.
- Connect the dummy load (8Ω, 80 watts) to the output terminal.
 - Connect the audio generator to the MAIN-IN jack. Oscilloscope and AC VTVM are connected across the dummy.
 - Feed the 1 kHz signal to the set.
 - Before checking the idling current, turn on power switch in a few minutes, adjust the variable resistor (VR_q 3,4) so that tester (or DC VTVM) coupling to the collector of transistors indicates 50 mA (Fig. 2). At the same time check the waveform to be correct (Fig. 3).
Not getting the correct waveform on oscilloscope, check the collector current of each transistors. Because transistor of other channel is broken down.

LOUDSPEAKER PROTECTION CIRCUIT

By some reasons, output terminal is shorted or final transistors (Q₁~ 4) is breakdown, then relay works and protects the loudspeaker from damage. Not listening the sound, check the center voltage (see the differential amplifier stage). It is good that hand of meter indicates 0 ± 100mV. If it does more than that, check the transistors in final or drive stage. Protection circuit works without abnormality, it is causes that transistor (Q₅) is poor. Check and replace it. Do the transistor (Q₆) also.

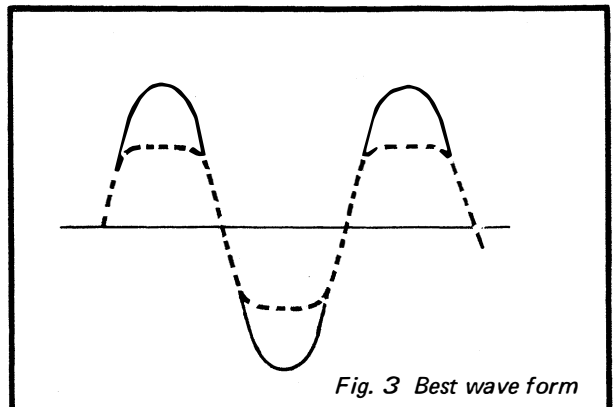
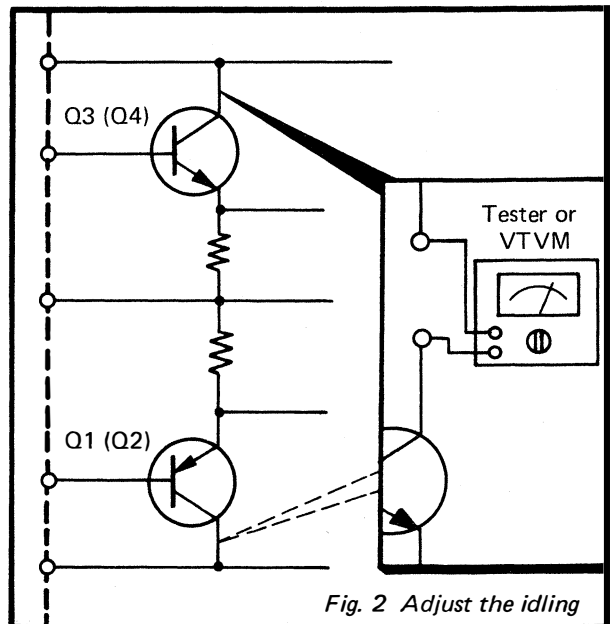
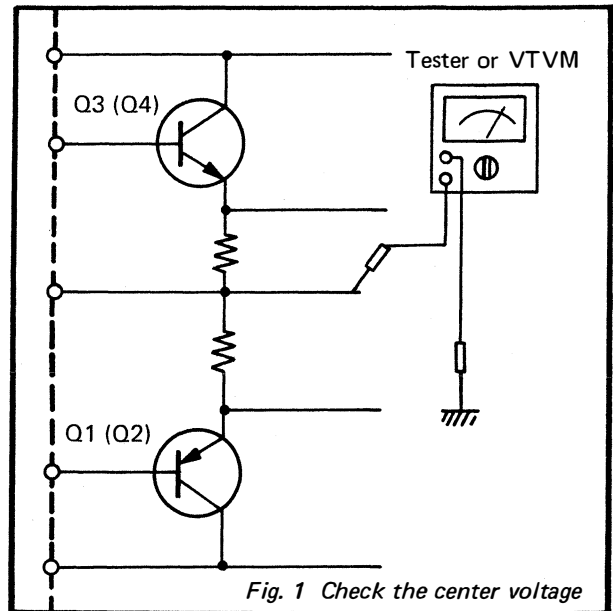

SCHEMATIC DIAGRAM

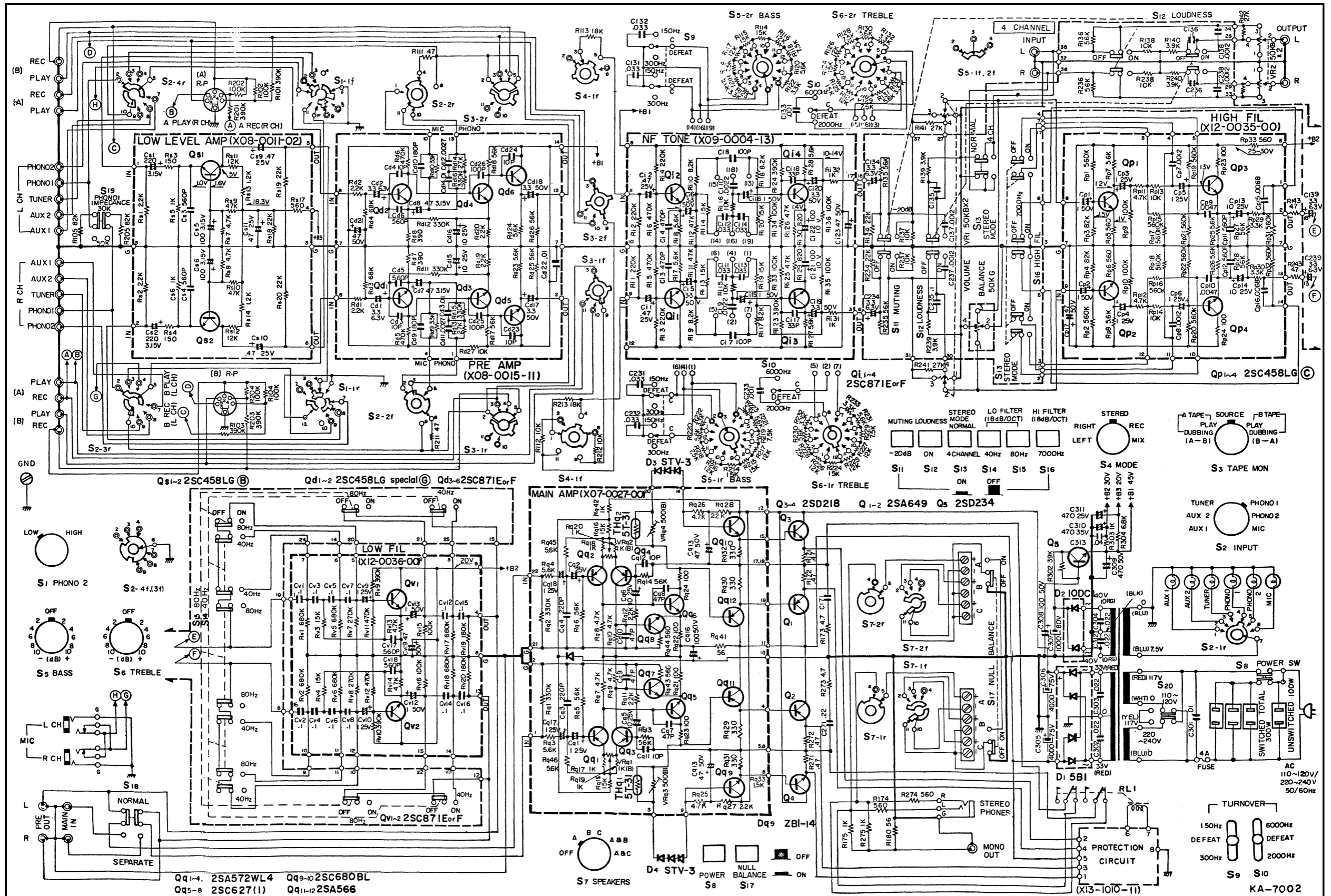

SCHEMATIC DIAGRAM

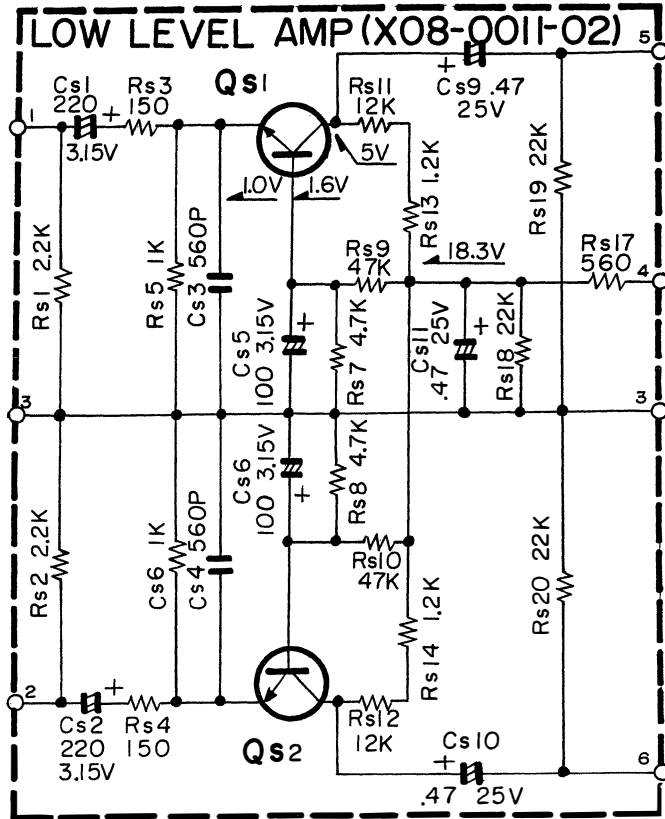

BOTTOM VIEW OF TRANSISTOR

2SC458LG(B)

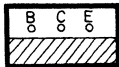

SEALED CIRCUIT ASSEMBLIES-PHANTOM VIEWS

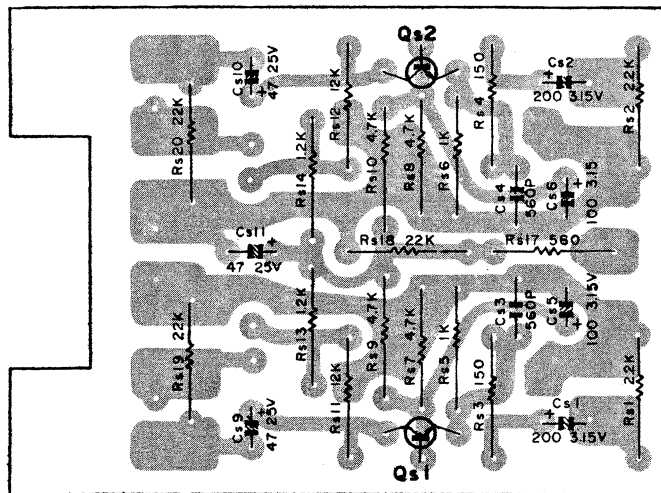

Qs1,2 2SC458LG(B)

**PARTS DESCRIPTION LIST**

Symbol No.	Description	Part No.	Remarks
CAPACITOR			
Cs1, 2	Electrolytic	220 μ F 3.15WV	CE04W0F221
Cs3, 4	Ceramic	560pF \pm 20%	CK94YY2H561MZ
Cs5, 6	Electrolytic	100 μ F 3.15WV	CE04W0F101
Cs9, 10	Tantalum	0.47 μ F 25WV	C90-0078-05
Cs11	Electrolytic	47 μ F 25WV	CE04W1E470
RESISTOR			
Rs1, 2	Insulated Carbon Film	2.2k Ω \pm 10% 1/4W	PD14BY2E222K
Rs3, 4	Insulated Carbon Film	150 Ω \pm 5% 1/4W	PD14BY2E151J
Rs5, 6	Insulated Carbon Film	1k Ω \pm 5% 1/4W	PD14BY2E102J
Rs7, 8	Insulated Carbon Film	4.7k Ω \pm 5% 1/4W	PD14BY2E472J
Rs9, 10	Insulated Carbon Film	47k Ω \pm 5% 1/4W	PD14BY2E473J
Rs11, 12	Insulated Carbon Film	12k Ω \pm 5% 1/4W	R92-0018-05
Rs13, 14	Insulated Carbon Film	1.2k Ω \pm 5% 1/4W	PD14BY2E122J
Rs17	Insulated Carbon Film	560 Ω \pm 5% 1/4W	PD14BY2E561J
Rs18	Insulated Carbon Film	22k Ω \pm 5% 1/4W	PD14BY2E223J
Rs19, 20	Insulated Carbon Film	22k Ω \pm 10% 1/4W	PD14BY2E223K
TRANSISTOR/etc.			
Qs1, 2	2SC458LG (B)		
—	PC Board	J25-0325-04	

SCHEMATIC DIAGRAM

BOTTOM VIEW OF TRANSISTOR

2SC458



2SC871

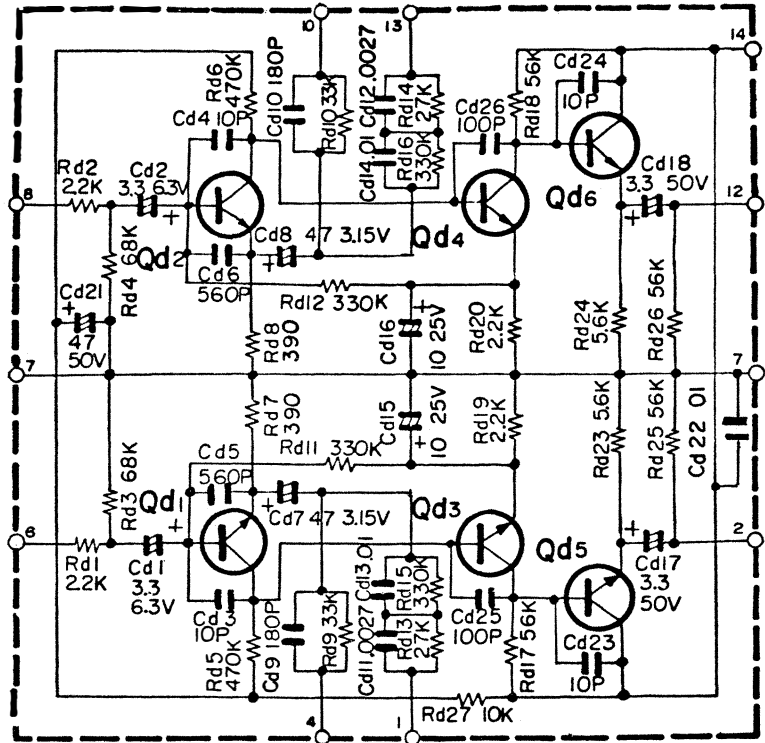

SEALED CIRCUIT ASSEMBLIES-PHANTOM VIEWS

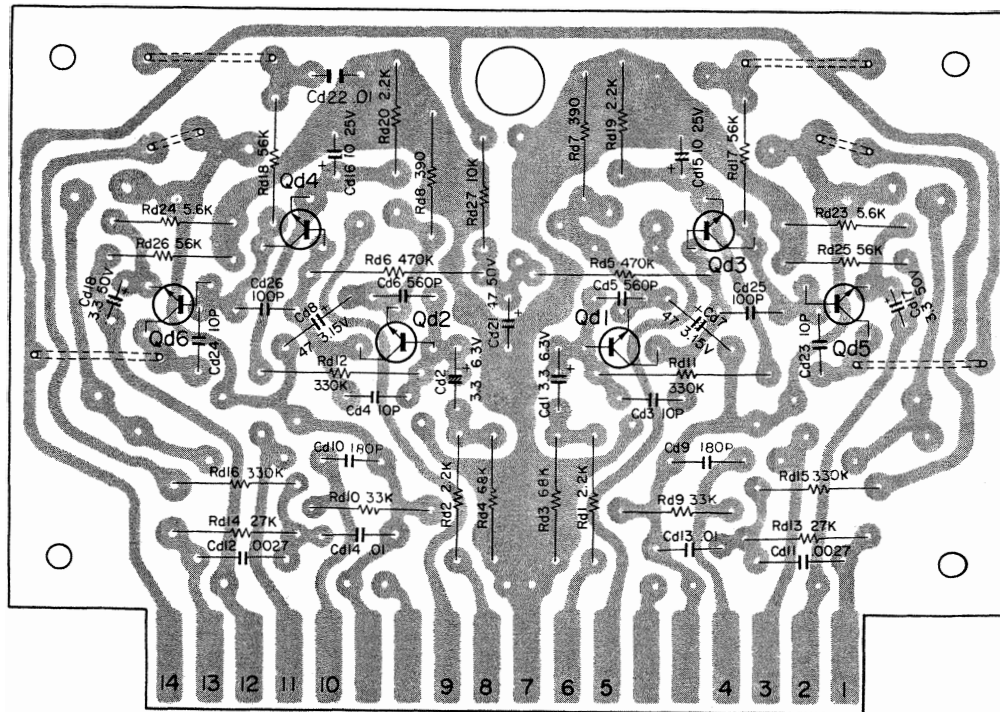

Qd1,2 2SC458LG(C)

Qd3~6 2SC871(E) or (F)

PARTS DESCRIPTION LIST

Symbol No.	Description	Part No.	Remarks
CAPACITOR			
Cd1, 2	Solid Aluminum	3.3 μ F 6.3WV	CA04E0J3R3XT
Cd3, 4	Ceramic	10pF \pm 10%	CC94SL1H100K
Cd5, 6	Ceramic	560pF \pm 20%	CK94YY1H561M
Cd7, 8	Electrolytic	47 μ F 6.3WV	CE04W0F470
Cd9, 10	Ceramic	180pF \pm 10%	CC94SL1H181K
Cd11, 12	Mylar	0.0027 μ F \pm 5%	CQ93M1H272J
Cd13, 14	Mylar	0.01 μ F \pm 5%	CQ93M1H103J
Cd15, 16	Electrolytic	10 μ F 25WV	CE04W1E100
Cd17, 18	Electrolytic	3.3 μ F 50WV	CE04W1H3R3
Cd21	Electrolytic	47 μ F 50WV	CE04W1H470
Cd22	Ceramic	0.01 μ F \pm 20%	CK94YY1H103M
Cd23, 24	Ceramic	10pF \pm 10%	CC94SL1H100K
Cd25, 26	Ceramic	100pF \pm 10%	CC94SL1H101K
RESISTOR			
Rd1, 2	Insulated Carbon Film	2.2k Ω \pm 10% 1/4W	PD14BY2E222K
Rd3, 4	Insulated Carbon Film	68k Ω \pm 10% 1/4W	PD14BY2E683K
Rd5, 6	Insulated Carbon Film	470k Ω \pm 10% 1/4W	R92-0053-05
Rd7, 8	Insulated Carbon Film	390 Ω \pm 5% 1/4W	PD14BY2E391J
Rd9, 10	Insulated Carbon Film	33k Ω \pm 5% 1/4W	PD14BY2E333J
Rd11, 12	Insulated Carbon Film	330k Ω \pm 5% 1/4W	R92-0026-05
Rd13, 14	Insulated Carbon Film	27k Ω \pm 5% 1/4W	PD14BY2E273J
Rd15, 16	Insulated Carbon Film	330k Ω \pm 5% 1/4W	PD14BY2E334J
Rd17, 18	Insulated Carbon Film	56k Ω \pm 10% 1/4W	PD14BY2E563K
Rd19, 20	Insulated Carbon Film	2.2k Ω \pm 10% 1/4W	PD14BY2E222K
Rd23, 24	Insulated Carbon Film	5.6k Ω \pm 10% 1/4W	PD14BY2E562K
Rd25, 26	Insulated Carbon Film	56k Ω \pm 10% 1/4W	PD14BY2E563K
Rd27	Insulated Carbon Film	10k Ω \pm 10% 1/4W	PD14BY2E103K
TRANSISTOR/etc.			
Qd1, 2	2SC458 LG (C)		
Qd3 ~ 6	2SC871 (E) or (F)		
—	PC Board	J25-0425-04	

SCHEMATIC DIAGRAM

BOTTOM VIEW OF TRANSISTOR

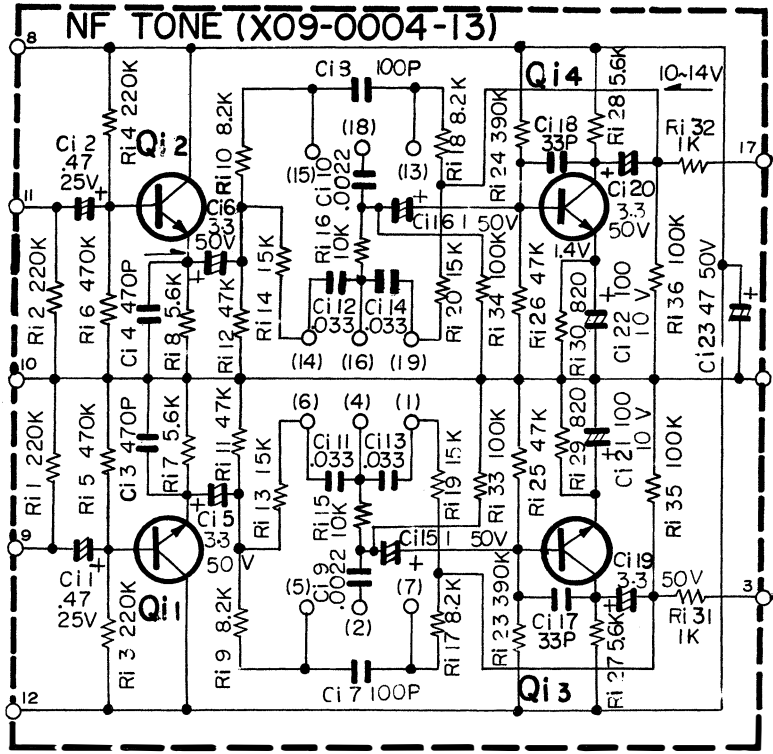
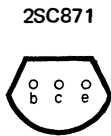

SEALED CIRCUIT ASSEMBLIES-PHANTOM VIEWS

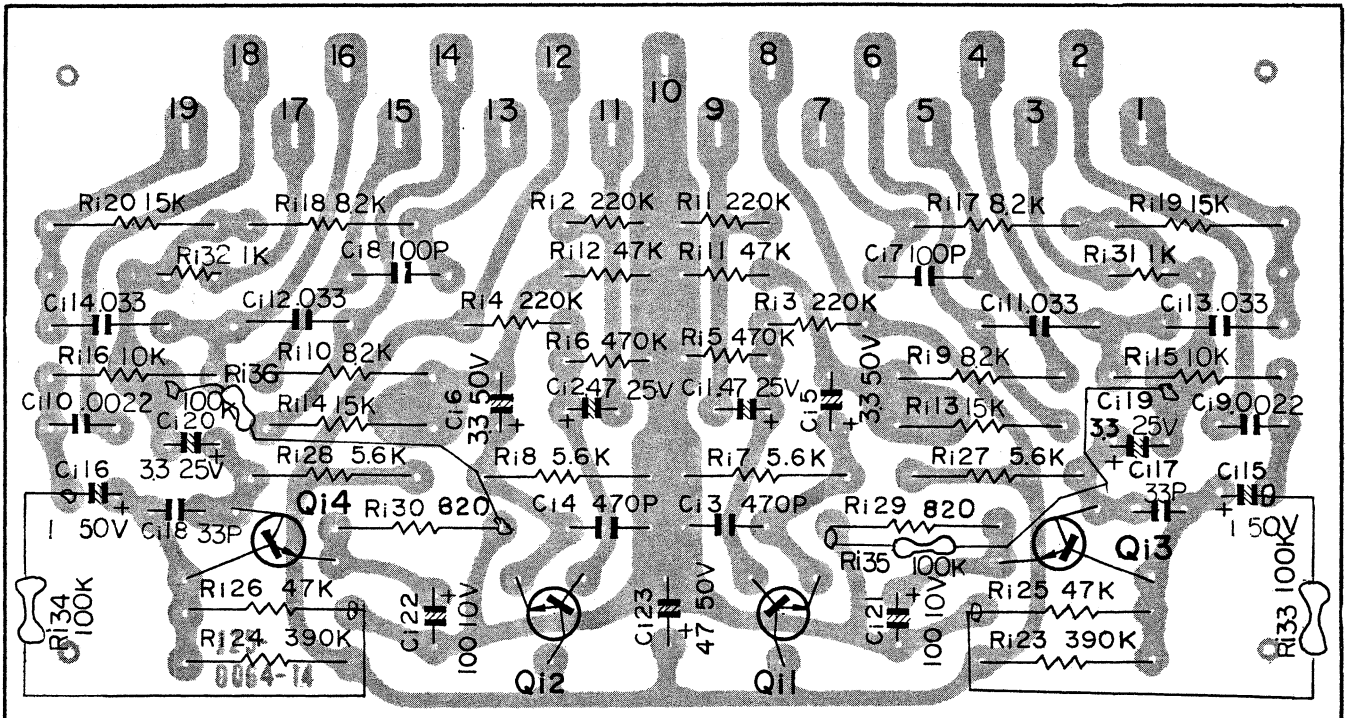

Q1~4 2SC871(E) or (F).

**PARTS DESCRIPTION LIST**

Symbol No.	Description	Part No.	Remarks
CAPACITOR			
Ci1, 2	Solid Aluminum	0.47 μ F 25WV	CA06E1ER47X or M
Ci3, 4	Ceramic	470pF \pm 20%	CK94YY1H471M
Ci5, 6	Electrolytic	3.3 μ F 50WV	CE04W1H3R3
Ci7, 8	Polyester	100pF \pm 10%	CQ08S1H101K
Ci9, 10	Mylar	0.0022 μ F \pm 5%	CQ93M1H222J
Ci11 ~ 14	Mylar	0.033 μ F \pm 5%	CQ93M1H333J
Ci15, 16	Electrolytic	1 μ F 50WV	CE04W1H010
Ci17, 18	Ceramic	33pF \pm 10%	CC94SL1H330K
Ci19, 20	Electrolytic	3.3 μ F 50WV	CE04W1H3R3
Ci21, 22	Electrolytic	100 μ F 10WV	CE04W1A101
Ci23	Electrolytic	47 μ F 50WV	CE04W1H470
RESISTOR			
Ri1 ~ 4	Insulated Carbon Film	220k Ω \pm 10% 1/4W	PD14CY2E224K
Ri5, 6	Insulated Carbon Film	470k Ω \pm 10% 1/4W	PD14CY2E474K
Ri7, 8	Insulated Carbon Film	5.6k Ω \pm 10% 1/4W	PD14CY2E562K
Ri9, 10	Insulated Carbon Film	8.2k Ω \pm 5% 1/4W	PD14CY2E822J
Ri11, 12	Insulated Carbon Film	47k Ω \pm 10% 1/4W	PD14CY2E473K
Ri13, 14	Insulated Carbon Film	15k Ω \pm 10% 1/4W	PD14CY2E153K
Ri15, 16	Insulated Carbon Film	10k Ω \pm 5% 1/4W	PD14CY2E103J
Ri17, 18	Insulated Carbon Film	8.2k Ω \pm 5% 1/4W	PD14CY2E822J
Ri19, 20	Insulated Carbon Film	15k Ω \pm 10% 1/4W	PD14CY2E153K
Ri23, 24	Insulated Carbon Film	390k Ω \pm 10% 1/4W	PD14CY2E394K
Ri25, 26	Insulated Carbon Film	47k Ω \pm 10% 1/4W	PD14CY2E473K
Ri27, 28	Insulated Carbon Film	5.6k Ω \pm 10% 1/4W	PD14CY2E562K
Ri29, 30	Insulated Carbon Film	820 Ω \pm 10% 1/4W	PD14CY2E821K
Ri31, 32	Insulated Carbon Film	1k Ω \pm 10% 1/4W	PD14CY2E102K
Ri33 ~ 36	Insulated Carbon Film	100k Ω \pm 10% 1/4W	PD14CY2E104K
TRANSISTOR/etc.			
Qi1 ~ 4 —	2SC871 (E) or (F) PC Board	J25-0064-14	



PARTS DESCRIPTION LIST

Symbol No.	Description	Part No.	Remarks
CAPACITOR			
Cp1, 2	Electrolytic	1 μ F 50WV	CE04W1H010
Cp3 ~ 6	Tantalum	1 μ F 25WV	C90-0079-05
Cp7, 8	Mylar	0.0012 μ F \pm 10%	CQ93M1H122K
Cp9, 10	Mylar	0.0047 μ F \pm 10%	CQ93M1H472K
Cp11, 12	Ceramic	560pF \pm 20%	CK94YY1H561M
Cp13, 14	Electrolytic	10 μ F 25WV	CE04W1E100
Cp15, 16	Mylar	0.0068 μ F \pm 10%	CQ93M1H682K
Cp17	Electrolytic	47 μ F 50WV	CE04W1H470
RESISTOR			
Rp1, 2	Insulated Carbon Film	560k Ω \pm 5% 1/4W	PD14BY2E564J
Rp3, 4	Insulated Carbon Film	82k Ω \pm 5% 1/4W	PD14BY2E823J
Rp5, 6	Insulated Carbon Film	560 Ω \pm 5% 1/4W	PD14BY2E561J
Rp7, 8	Insulated Carbon Film	5.6k Ω \pm 5% 1/4W	PD14BY2E562J
Rp9, 10	Insulated Carbon Film	100k Ω \pm 5% 1/4W	PD14BY2E104J
Rp11, 12	Insulated Carbon Film	4.7k Ω \pm 5% 1/4W	PD14BY2E472J
Rp13, 14	Insulated Carbon Film	10k Ω \pm 5% 1/4W	PD14BY2E103J
Rp15 ~ 22	Insulated Carbon Film	560k Ω \pm 5% 1/4W	PD14BY2E564J
Rp23, 24	Insulated Carbon Film	100 Ω \pm 5% 1/4W	PD14BY2E101J
Rp25, 26	Insulated Carbon Film	5.6k Ω \pm 5% 1/4W	PD14BY2E562J
Rp27, 28	Insulated Carbon Film	56k Ω \pm 5% 1/4W	PD14BY2E563J
Rp29, 30	Insulated Carbon Film	3.3k Ω \pm 5% 1/4W	PD14BY2E332J
Rp31, 32	Insulated Carbon Film	560k Ω \pm 5% 1/4W	PD14BY2E564J
Rp33	Insulated Carbon Film	560 Ω \pm 5% 1/4W	PD14BY2E561J
TRANSISTOR/etc.			
Qp1, 2	2SC458LG (C)		
—	PC Board	J25-0489-04	

SCHEMATIC DIAGRAM

BOTTOM VIEW OF TRANSISTOR

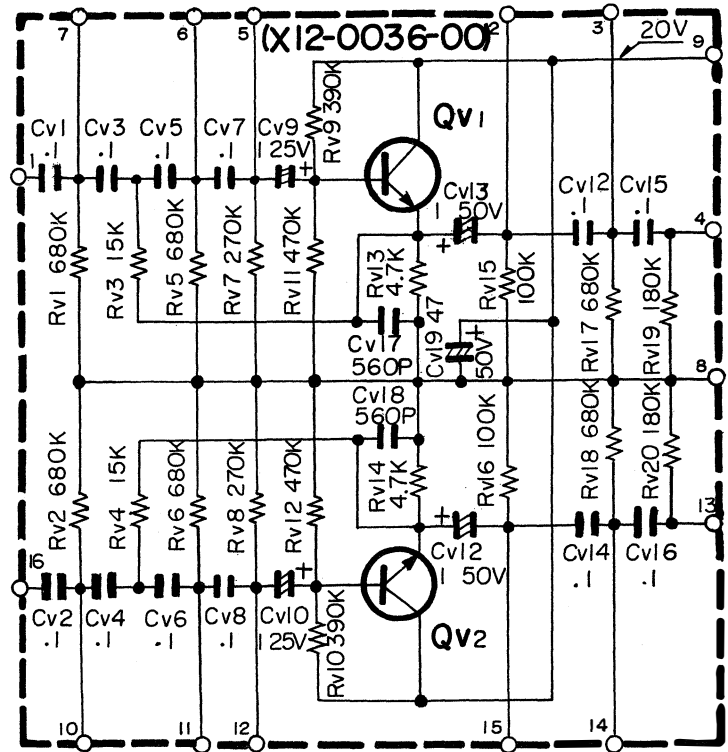
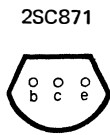

SEALED CIRCUIT ASSEMBLIES-PHANTOM VIEWS

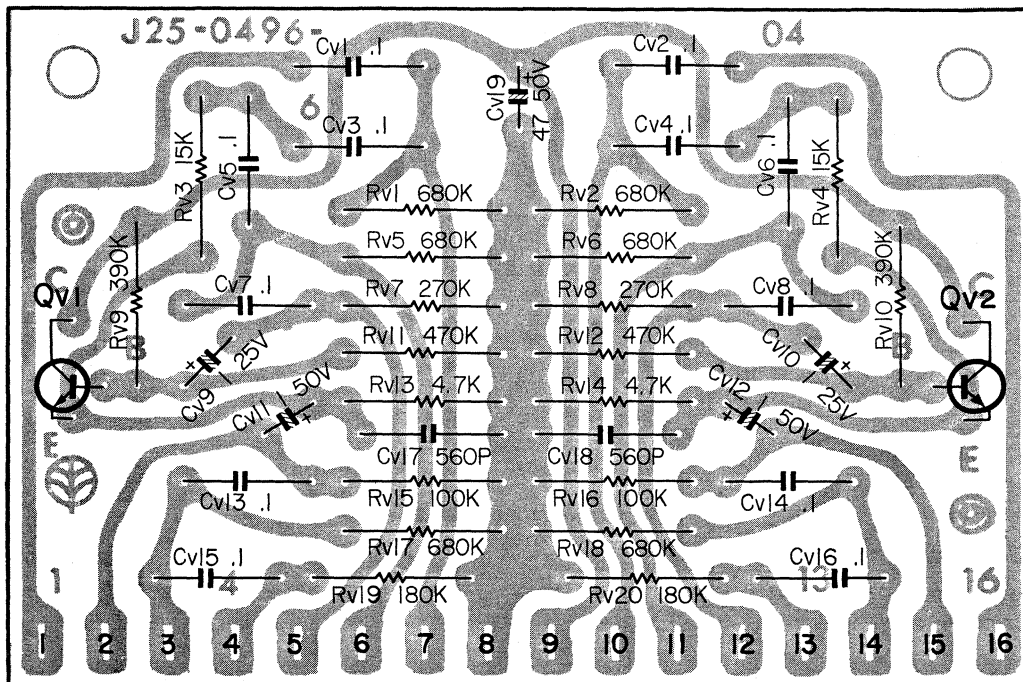

QV1,2 2SC871

**PARTS DESCRIPTION LIST**

Symbol No.	Description	Part No.	Remarks
CAPACITOR			
Cv1 ~ 8	Mylar	0.1 μ F \pm 10%	CQ93M1H104K
Cv9, 10	Tantalum	1 μ F 25WV	C90-0079-05
Cv11, 12	Electrolytic	1 μ F 50WV	CE04W1H010
Cv13 ~ 16	Mylar	0.1 μ F \pm 10%	CQ93M1H104K
Cv17, 18	Ceramic	560pF \pm 20%	CK94YY1H561M
Cv19	Electrolytic	47 μ F 50WV	CE04W1H470
RESISTOR			
Rv1, 2	Insulated Carbon Film	680k Ω \pm 5% 1/4W	PD14BY2E684J
Rv3, 4	Insulated Carbon Film	15k Ω \pm 5% 1/4W	PD14BY2E153J
Rv5, 6	Insulated Carbon Film	680k Ω \pm 5% 1/4W	PD14BY2E684J
Rv7, 8	Insulated Carbon Film	270k Ω \pm 5% 1/4W	PD14BY2E274J
Rv9, 10	Insulated Carbon Film	390k Ω \pm 5% 1/4W	PD14BY2E394J
Rv11, 12	Insulated Carbon Film	470k Ω \pm 5% 1/4W	PD14BY2E474J
Rv13, 14	Insulated Carbon Film	4.7k Ω \pm 5% 1/4W	PD14BY2E472J
Rv15, 16	Insulated Carbon Film	100k Ω \pm 5% 1/4W	PD14BY2E104J
Rv17, 18	Insulated Carbon Film	680k Ω \pm 5% 1/4W	PD14BY2E684J
Rv19, 20	Insulated Carbon Film	180k Ω \pm 5% 1/4W	PD14BY2E184J
TRANSISTOR/etc.			
Qv1, 2	2SC871 (E) or (F)		
—	PC Board	J25-0496-04	

SCHEMATIC DIAGRAM

BOTTOM VIEW OF TRANSISTOR

2SA572WL4



2SC627

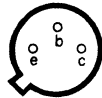

2SC680BL
2SA566

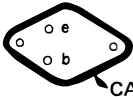

CASE
COLLECTOR

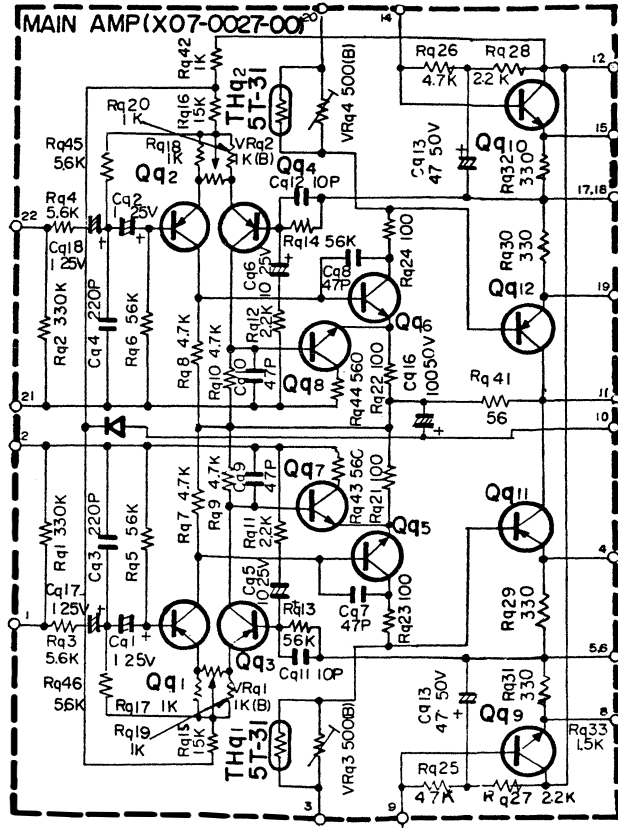

SEALED CIRCUIT ASSEMBLIES-PHANTOM VIEWS

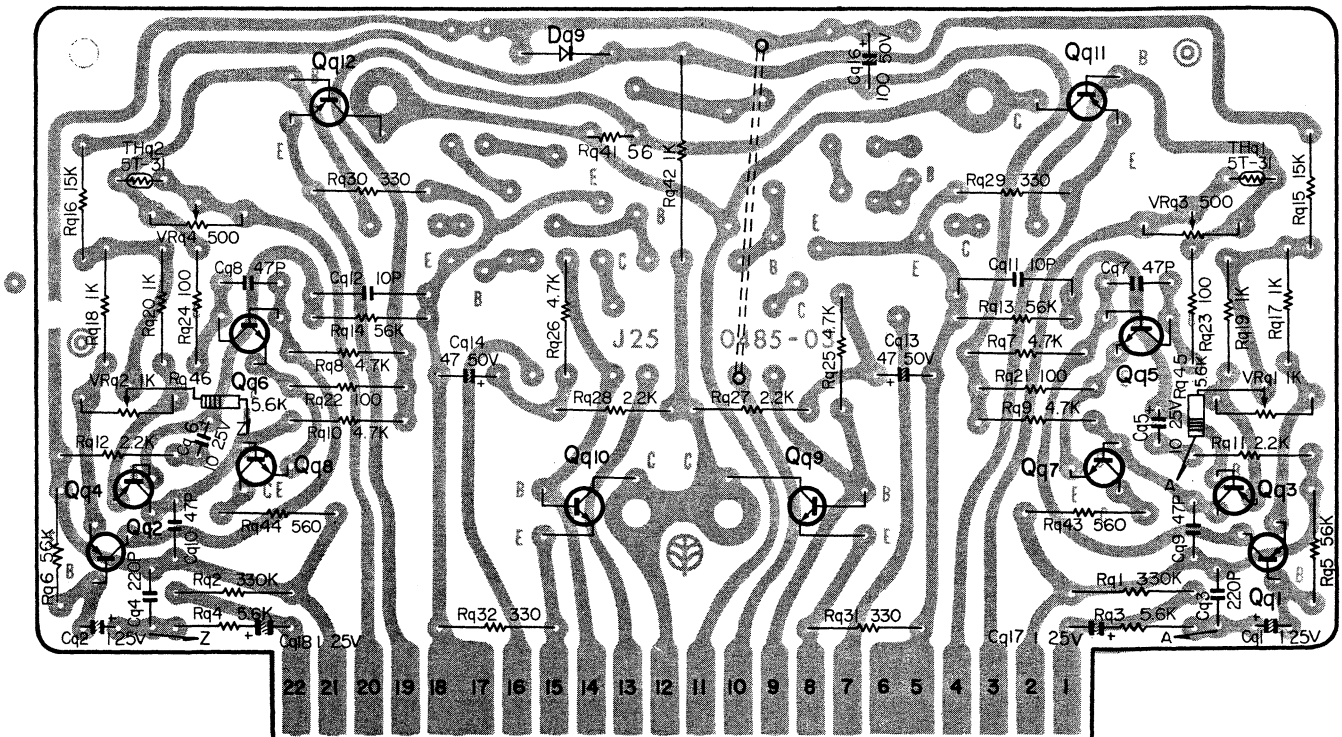

Qq1 ~ 4 2SA572WL4, Qq5 ~ 8 2SC627 (1), Qq9, 10 2SC680BL, Qq11, 12 2SA566, Dq9ZB1-14



PARTS DESCRIPTION LIST

Symbol No.	Description				Part No.	Remarks
CAPACITOR						
Cq1, 2	Electrolytic	1 μ F	25WV		CE04W1E010	
Cq3, 4	Ceramic	220pF	\pm 10%		CC94SL1H221K	
Cq5, 6	Electrolytic	10 μ F	25WV		CE04W1E100	
Cq7 ~ 10	Ceramic	47pF	\pm 10%		CC94SL1H470K	
Cq11, 12	Ceramic	10pF	\pm 0.5pF		CC94SL1H100D	
Cq13, 14	Electrolytic	47 μ F	50WV		CE04W1H470	
Cq16	Electrolytic	100 μ F	50WV		CE04W1H101	
Cq17, 18	Electrolytic	1 μ F	25WV		CE04W1E010M	
RESISTOR						
Rq1, 2	Insulated Carbon Film	330k Ω	\pm 5%	1/4W	PD14BY2E334J	
Rq3, 4	Insulated Carbon Film	5.6k Ω	\pm 5%	1/4W	PD14BY2E562J	
Rq5, 6	Insulated Carbon Film	56k Ω	\pm 5%	1/4W	PD14BY2E563J	
Rq7 ~ 10	Insulated Carbon Film	4.7k Ω	\pm 5%	1/4W	PD14BY2E472J	
Rq11, 12	Insulated Carbon Film	2.2k Ω	\pm 5%	1/4W	PD14BY2E222J	
Rq13, 14	Insulated Carbon Film	56k Ω	\pm 5%	1/4W	PD14BY2E563J	
Rq15, 16	Insulated Carbon Film	15k Ω	\pm 5%	1/4W	PD14BY2E153J	
Rq17 ~ 20	Insulated Carbon Film	1k Ω	\pm 5%	1/4W	PD14BY2E102J	
Rq21 ~ 24	Insulated Carbon Film	100 Ω	\pm 5%	1/4W	PD14BY2E101J	
Rq25, 26	Insulated Carbon Film	4.7k Ω	\pm 5%	1/4W	PD14BY2E472J	
Rq27, 28	Insulated Carbon Film	2.2k Ω	\pm 5%	1/4W	PD14BY2E222J	
Rq29 ~ 32	Insulated Carbon Film	330 Ω	\pm 5%	1/4W	PD14BY2E331J	
Rq41	Insulated Carbon Film	56 Ω	\pm 5%	1/4W	PD14BY2E560J	
Rq42	Metal Film	1k Ω	\pm 10%	2W	RN14AB3D102K	
Rq43, 44	Insulated Carbon Film	560 Ω	\pm 5%	1/4W	PD14BY2E561J	
Rq45, 46	Insulated Carbon Film	5.6k Ω	\pm 5%	1/4W	PD14BY2E562J	
TRANSISTOR/DIODE/THERMISTOR						
Qq1 ~ 4	2SA572WL4					
Qq5 ~ 8	2SC627 (1)					
Qq9, 10	2SC680BL					
Qq11, 12	2SA566					
Dq9	ZB1-14					
THq1, 2	5T-31					
POTENTIOMETER/etc.						
VRq1, 2	1k Ω (B)				R12-1007-05	
VRq3, 4	500 Ω (B)				R12-0026-05	
—	PC Board				J25-0485-03	

SCHEMATIC DIAGRAM

BOTTOM VIEW OF TRANSISTOR

- 2SC627(1)
- 2SC497R
- 2SA497R

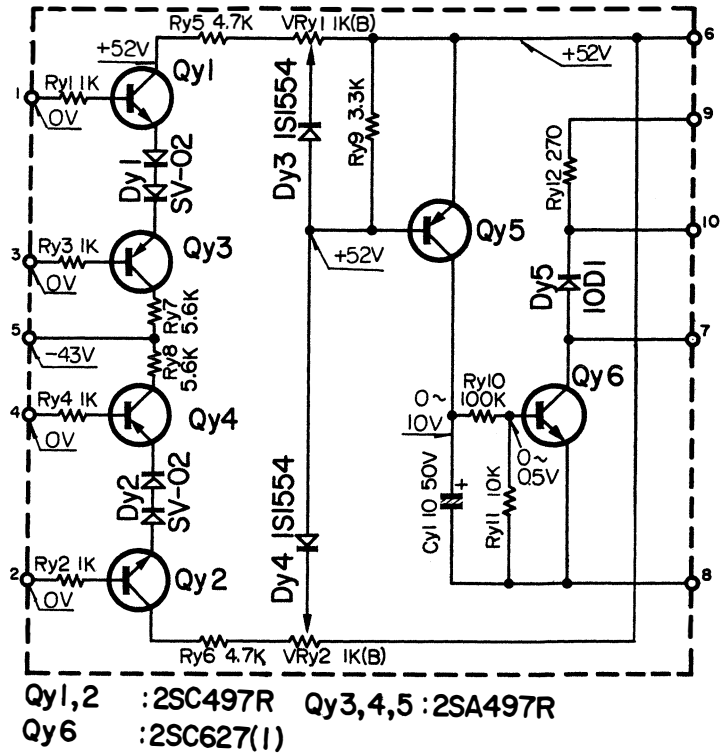
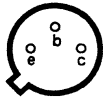

SEALED CIRCUIT ASSEMBLIES-PHANTOM VIEWS

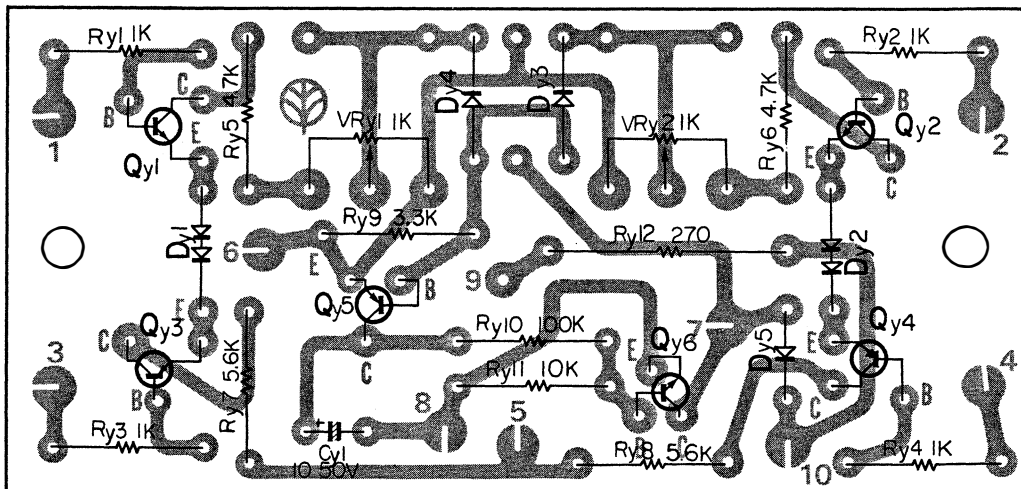

Qy1,2 : 2SC497(R), Qy3,4,5 : 2SA497(R), Qy6 : 2SC627(1)
 Dy1,2 : SV-02, Dy3,4 : IS1554, Dy5 : IOD1



KENWOOD® PROTECTION AMP (X13-1010-11) SECTION

PARTS DESCRIPTION LIST

Symbol No.	Description	Part No.	Remarks
CAPACITOR			
Cy1	Electrolytic 10 μ F 50VV	CE04W1H100	
RESISTOR			
Ry1~4	Insulated Carbon Film 1k Ω \pm 5% 1/4W	PD14BY2E102J	
Ry5, 6	Insulated Carbon Film 4.7k Ω \pm 5% 1/4W	PD14BY2E472J	
Ry7, 8	Insulated Carbon Film 5.6k Ω \pm 5% 1/4W	PD14BY2E562J	
Ry9	Insulated Carbon Film 3.3k Ω \pm 5% 1/4W	PD14BY2E332J	
Ry10	Insulated Carbon Film 100k Ω \pm 5% 1/4W	PD14BY2E104J	
Ry11	Insulated Carbon Film 10k Ω \pm 5% 1/4W	PD14BY2E103J	
Ry12	Metal Film 270 Ω \pm 10% 2W	RN14AB3D271K	
TRANSISTOR/DIODE/POTENTIOMETER			
Qy1, 2	2SC497R		
Qy3~5	2SA497R		
Qy6	2SC627 (1)		
Dy1, 2	SV-02		
Dy3, 4	1S1554		
Dy5	10D1		
VRy1, 2	1k Ω (B)	R12-1012-05	
etc.			
—	P. C. Board	J25-0535-04	